



Instructions for Fitting, Operating and Maintenance
Garage door operator

GA403-403 TG

4Ddoors

GARAGE DOORS REDEFINED

www.4Ddoors.com



A

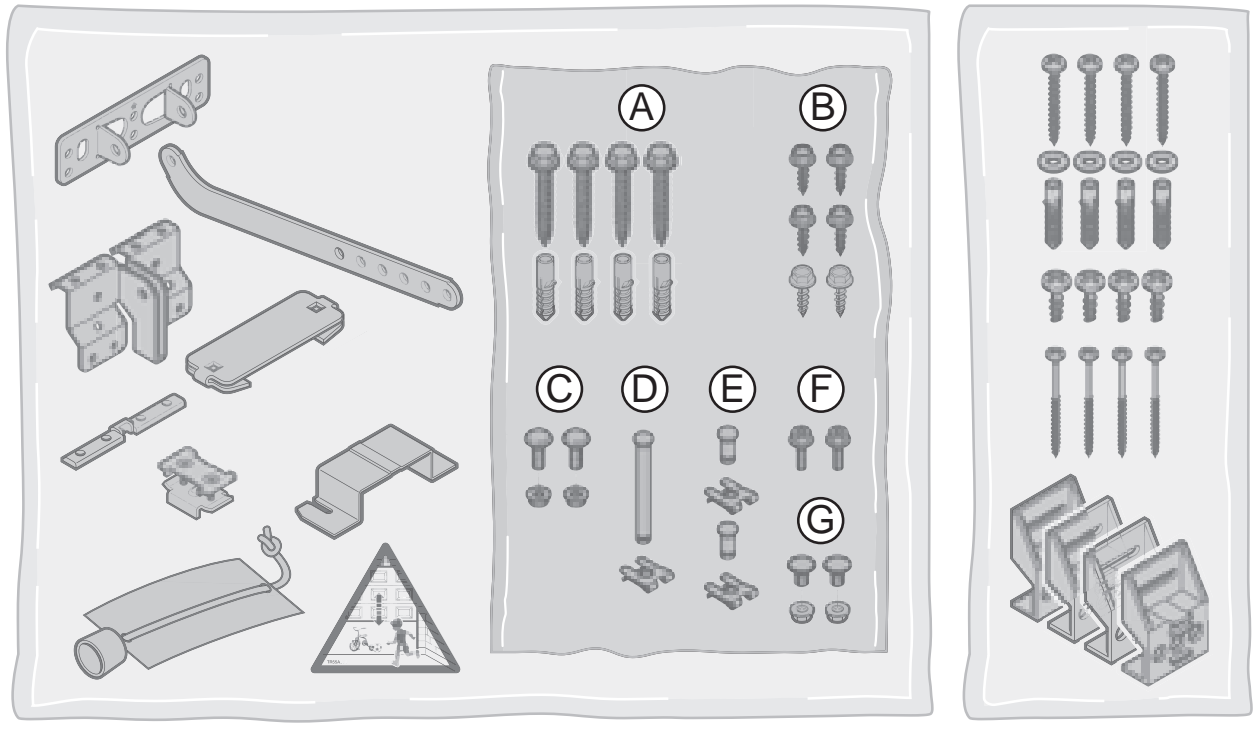
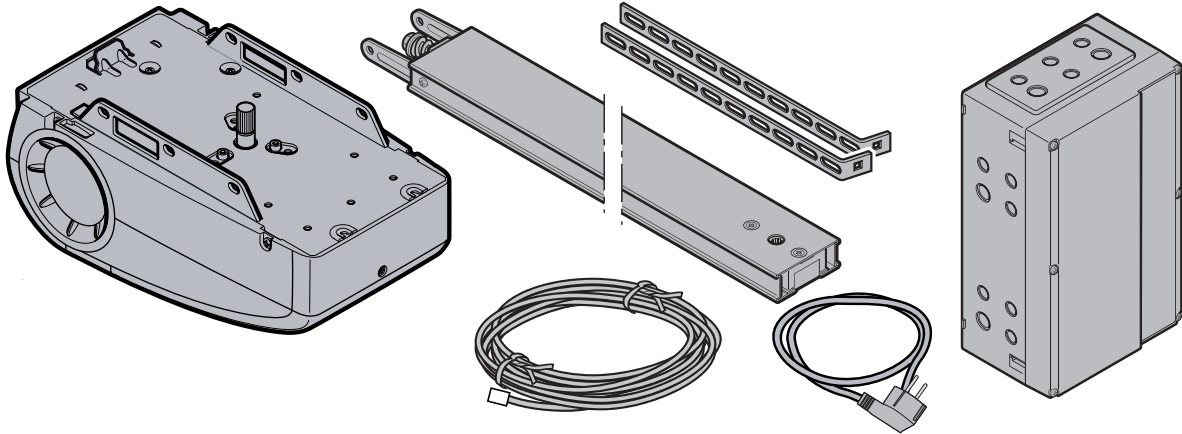

B

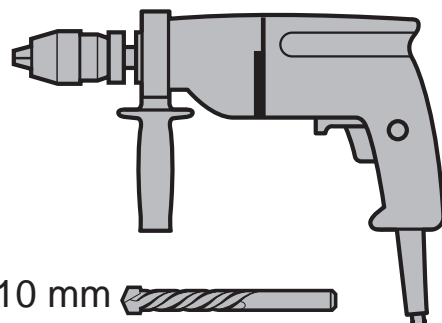



Table of contents

1	ABOUT THESE INSTRUCTIONS	4	10	MENU OVERVIEW	16
1.1	Further applicable documents	4	10.1	Functional examples	17
2	INSTRUCTIONS	4	10.2	Command inputs (shown on the display)	17
2.1	Intended use.	4	10.3	Functions of circuit board buttons TA1 and TA3:	17
2.2	Non-intended use.	4	10.4	Status display	17
2.3	Fitter qualification	4	11	ERROR TABLE	18
2.4	Warnings used	4	12	ERROR MESSAGE FLASHES 4X - PERFORM REFERENCE RUN	20
2.5	International colour code according to IEC 757	4	13	FORCE SYNCHRONISATION RUN	20
2.6	Information on the illustrated section	4	14	OPERATION	21
2.7	Symbols used	4	14.1	Instructing users	21
3	SAFETY INSTRUCTIONS	5	14.2	Safety reversal	21
3.1	Safety instructions for fitting.	5	14.3	Functions of various radio codes	21
4	FITTING	6	14.4	Behaviour during a power failure / Behaviour after the power returns	21
4.1	Inspect door / door system	6	15	INSPECTION AND MAINTENANCE	22
4.2	Clearance required	6	16	DISMANTLING AND DISPOSAL	22
4.3	Preparing the door	6	17	WARRANTY CONDITIONS	22
4.4	Fitting the boom	6	17.1	Warranty	22
4.5	Boom operating modes	6	17.2	Warranty period	22
4.6	Emergency release	6	17.3	Prerequisites	22
4.7	Fitting the Close end stop.	7	17.4	Performance.	22
4.8	Tension of the toothed belt	7	18	TECHNICAL DATA	23
4.9	Fitting the operator head	7	HANDOVER REPORT FOR GARAGE DOOR OPENER 39		
4.10	Fixing the warning sign.	7			
4.11	Install drive control	7	ILLUSTRATED SECTION 24		
4.12	Electrically connect the drive/control	7			
5	INITIAL START-UP	8			
5.1	Teaching in the operator	8			
5.2	Teaching in the Partial opening function	9			
5.3	Deleting door data	9			
6	INSTALL ACCESSORIES	9			
6.1	Electrical connection / Connection terminals	9			
6.2	External receiver	9			
6.3	External impulse button	9			
6.4	Wicket door contact / Stop contact	10			
6.5	Contact photocell for safety recoil	10			
6.6	Two-wire photocell for safety recoil	10			
6.7	Closing edge safety device 8k2	10			
6.8	Optical closing edge safety device	11			
6.9	Warning light via option relay	11			
6.10	External lamp via option relay	11			
6.11	Close Door display via option relay	11			
6.12	Open Door display via option relay	11			
6.13	Light output 24 VDC.	12			
6.14	Timer contact for Permanently Open command	12			
7	CIRCUIT BOARD OVERVIEW MS550	13			
8	CONTROL SYSTEM MS550	14			
8.1	Operate menu control system MS550	14			
8.2	Example for a menu change	14			
9	SPECIAL FUNCTIONS	15			
9.1	Suppressing the light barrier	15			
9.2	Programming the reversal limit for the advanced light barrier (VL1/VL2).	15			

Dear Customer,

We are delighted that you have chosen a quality product from our company.

1 ABOUT THESE INSTRUCTIONS

- These instructions are original operating instructions as outlined in the EC Directive 2006/42/EC. Read through all of the instructions carefully, as they contain important information about the product. Pay attention to and follow the instructions provided, particularly the safety instructions and warnings.
- Please keep these instructions in a safe place and make sure that they are available to all users at all times!
- Instructions in languages other than German are translations of these original operating instructions.

1.1 Further applicable documents

The following documents for safe handling and maintenance of the door system must be placed at the disposal of the end user:

- These instructions
- The garage door operating instructions

2 INSTRUCTIONS

2.1 Intended use

- The garage door operator is intended exclusively for impulse operation of spring-compensated sectional and up-and-over doors in the private / non-commercial sector.
- Note the manufacturer's specifications regarding the door and operator combination. Potential hazards as outlined in DIN EN 13241-1 are avoided by construction and fitting according to our guidelines. Door systems that are located in a public area and which only have one protective device, such as a power limit, may only be operated under supervision.
- The garage door operator is designed for operation in dry areas.

2.2 Non-intended use

- The operator must **not** be used for doors without a safety catch.
- The garage door opener must **not** be installed outside. Parts of the door must not extend onto public footpaths or streets.
- The garage door opener must **not** be operated in **explosive environments**.
- The construction of the operator is **not** designed for operation with sluggish doors, i.e. doors that can hardly or not at all be opened or closed manually.

2.3 Fitter qualification

Only correct fitting and maintenance in compliance with the instructions by a competent / specialist company or a competent / qualified person ensures safe and flawless operation of the system. According to EN 12635, a specialist is a person with suitable training, specialist knowledge and practical experience sufficient to correctly and safely fit, test, and maintain a door system.

2.4 Warnings used

	The general warning symbol indicates a danger that can lead to injury or death .
---	--

In this manual, the general warning symbol will be used in connection with the caution levels described below.

	DANGER! Indicates a danger that can immediately lead to death or serious injuries.
	WARNING! Indicates a danger that can lead to death or serious injuries.
	CAUTION! Indicates a danger that can lead to minor or moderate injuries.
	ATTENTION! Indicates a danger that can lead to damage or destruction of the product .

2.5 International colour code according to IEC 757

WH	White	GN	Green
BN	Brown	YE	Yellow
BK	Black	RD	Red
OG	Orange	BU	Blue
GY	Grey	VT	Violet
RS	Pink		

2.6 Information on the illustrated section

The illustrated section shows how to fit the operator on a sectional door. Deviations for fitting with an up-and-over door are also shown. For this purpose, the following letters are assigned to the figures:

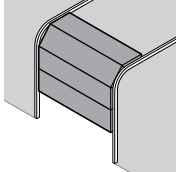
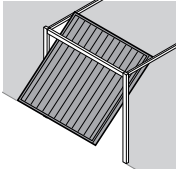
	(a) = Sectional door
	(b) = Up-and-over door

2.7 Symbols used

	2.5	= See text section 2.5
---	------------	------------------------

	= Factory setting
---	-------------------

3 SAFETY INSTRUCTIONS



WARNING!

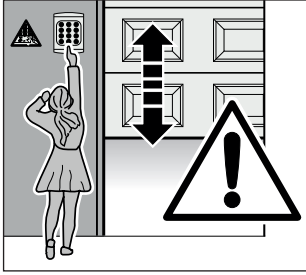

Danger of injury due to unwanted door travel!
 Incorrect assembly or handling of the operator may trigger unwanted door travel that may result in persons or objects being trapped.

- ▶ Follow all the instructions provided in this manual.
- ▶ Install control devices at a height of at least 1.5 m (out of the reach of children).
- ▶ Fit permanently installed control devices (such as buttons, etc.) within sight of the door, but away from moving parts.

Incorrectly fitted control devices (e.g. buttons) may trigger unwanted door travel. Persons or objects may be jammed as a result.



WARNING!

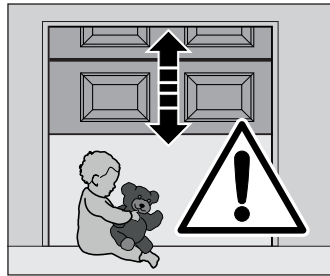



Danger of injury during door travel!
 If people or objects are in the area around the door while the door is in motion, this can lead to injuries or damage.

- ▶ Children are not allowed to play near the door system.
- ▶ Make sure that no persons or objects are in the door's area of travel.
- ▶ If the door system has only one safety feature, only operate the garage door operator if you are within sight of the door's area of travel.
- ▶ Monitor the door travel until the door has reached the end-of-travel position.
- ▶ Only drive or pass through remote control door systems if the door is in the Open end-of-travel position!
- ▶ Never stay standing under the open door.

3.1 Safety instructions for fitting

- The specialist carrying out the work must ensure that installation is conducted in compliance with the prevailing national job safety rules and regulations and those governing the operation of electrical equipment. In the process, the relevant national guidelines must be observed. Potential hazards as outlined in DIN EN 13241-1 are avoided by construction and fitting according to our guidelines.
- The garage ceiling must guarantee secure fastening of the operator. For ceilings which are too high or too light, the operator must be fastened with additional struts.
- **The mains plug must be disconnected before any work is performed on the operator.**



DANGER!

Compensating springs are under high tension

Serious injuries may occur while adjusting or loosening the compensating springs!

- ▶ For your own safety, only have a specialist conduct work on the door compensating springs and, if necessary, maintenance and repair work!
- ▶ Never try to replace, adjust, repair or reposition the compensating springs for the counterbalance of the door or the spring mountings yourself.
- ▶ In addition, check the entire door system (joints, door bearings, cables, springs and fastenings) for wear and possible damage.
- ▶ Check for the presence of rust, corrosion, and cracks.

A malfunction in the door system or an incorrectly aligned door can cause serious injuries!

- ▶ Do not use the door system if repair or adjustment work must be conducted!



DANGER!

Risk to life due to persons being locked in!

In the case of garages without a second access point, an external emergency unlocking facility is necessary, in addition to the internal unlocking facility, to ensure that a person who is trapped inside and no longer able to free themselves can be freed by persons on the outside. This must be ordered separately and installed.

- ▶ Check the internal and external emergency unlocking facilities every month to ensure that they are functioning correctly.
- ▶ Faults or defects discovered must be rectified **immediately!**



ATTENTION!

In the case of garages without a second access point, an external emergency unlocking facility is necessary, in addition to the internal unlocking facility, to ensure that no-one is locked out in the event of a mains power failure. This must be ordered separately and installed.

- ▶ Check the internal and external emergency unlocking facilities every month to ensure that they are functioning correctly.
- ▶ Faults or defects discovered must be rectified **immediately!**

4 FITTING

4.1 Inspect door / door system

The door must be in a flawless mechanical condition, as well as correctly balanced, so that it can be easily operated by hand (EN 12604).

- ▶ Lift the door by approx. one metre and let it go. The door should stay in this position and neither move downward nor upward. If the door does move in either direction, there is a danger that the compensating springs / weights are not properly adjusted or are defective. In this case, increased wear and malfunctioning of the door system can be expected.
- ▶ Check whether the door can be opened and closed correctly.
- ▶ The mechanical locking devices of the door that are not needed with a garage door operator must be put out of commission. This especially includes the locking mechanisms of the door lock.
- ▶ The fitter must check that the fitting materials supplied are suitable for the purpose and the intended fitting location.

4.2 Clearance required

- The clearance between the highest point of door travel and the ceiling (even when opening the door) must be at least 30 mm. See Figures 1.1a and 1.2b.
- If the clearance is smaller, the operator can also be mounted behind the opened door if enough space is available. In this case, an extended fitting bracket (ordered separately) must be used.
- The garage door operator can be arranged up to max. 500 mm off-centre.

 **Check these dimensions!**

4.3 Preparing the door

 <h2 style="margin: 0;">WARNING!</h2>
<p>Danger to life from the pull rope! A running rope may lead to strangulation.</p> <ul style="list-style-type: none"> ▶ Remove the rope while fitting the operator (see Figure 1.2a).

- ▶ Completely disassemble the mechanical door locking on the sectional door. See figure 1.3a on **page 25**.
- ▶ With an off-centre reinforcement profile on the sectional door, fit the link bracket on the nearest reinforcement profile to the left or right. See figure 1.5a on **page 26**.
- ▶ For sectional doors with centre door locking, arrange the lintel joint and link bracket max. 50 cm off-centre. See figure 1.6a on **page 27**.
- ▶ Render the mechanical door locking on the up-and-over door inoperable. For door models not covered here, block the catches on site. See Figures 1.3b/1.4b/1.5b on **page 28**.
- ▶ In a deviation from the illustrated section, attach the lintel ceiling console and link bracket max. 50 cm off-centre for up-and-over doors with ornamental iron door handles. See figure 1.6b on **page 29**.
- ▶ For N 80 doors with timber infill, the bottom holes on the lintel joint must be used for fitting. See figure 1.7b on **page 29**.

4.4 Fitting the boom

 <h2 style="margin: 0;">WARNING!</h2>
<p>Unsuitable fixing material Use of unsuitable fixing material may mean that the operator is insecurely attached and could come loose.</p> <ul style="list-style-type: none"> ▶ The fitter must check the suitability of the provided fixing material (plugs) for use in the intended fitting location. ▶ Only use the provided fixing materials (plugs) in concrete \geq B15 (see Figures 1.6a/1.8b/2.4).

 <h2 style="margin: 0;">ATTENTION!</h2>
<ul style="list-style-type: none"> ▪ <i>Before the boom is fitted on the lintel and under the ceiling, shift the slide carriage approx. 20 cm towards the middle of the boom. This is no longer possible once the end stops and operator have been fitted.</i> ▪ <i>For operators used in underground and collective garages, it is necessary to fix the boom under the ceiling of the garage using a second suspension (see figure 2.4 and figure 2.5 on page 31).</i> ▪ <i>Only use the booms recommended by us for the garage door operators – depending on the respective application!</i> ▪ <i>Drilling dust and chippings can lead to malfunctions. Cover the operator during drilling work..</i>

Note

A second suspension is recommended with divided rails (available under accessories) (see figure 2.5 on **page 31**).

4.5 Boom operating modes

4.5.1 Manual operation

The slide carriage is disengaged from the belt lock to enable the door to be moved by hand. For disengaging the slide carriage: Pull on the cord of the mechanical release. See figure 4 on **page 34**.

4.5.2 Automated operation

The belt lock is engaged in the slide carriage to enable the door to be moved with the operator. For preparing the slide carriage for engaging:

- Press the green knob. See figure 6 on **page 34**
- Move the belt in the direction of the slide carriage until the belt lock engages.

4.6 Emergency release

 <h2 style="margin: 0;">WARNING!</h2>
<p>Danger of injury by fast-closing door! If the cord knob is actuated while the door is open, there is a danger that the door will close rapidly if the springs are weak, broken or defective, or if the counterbalance is inadequate.</p> <ul style="list-style-type: none"> ▶ Only pull the cord knob when the door is closed!

An emergency release is necessary for garages without a second entrance that prevents the possibility of being locked out; this must be ordered separately.

- ▶ Check the emergency release monthly for proper function.

4.7 Fitting the Close end stop

- Loosely insert the end stop in the boom between the slide carriage and door. Push the door into the Close end-of-travel position by hand.
- This will push the end stop into the correct position. See figure 5.2 on **page 34**.
- Fix the end stop.

Note

If the door cannot easily be pushed manually into the desired OPEN or CLOSE end-of-travel position, this means that the door mechanism is too stiff for operation with the garage door operator and must be inspected.

4.8 Tension of the toothed belt

The toothed belt of the operator boom is tensioned optimally ex-factory. During the start-up and slow-down phase, with larger doors it is possible that the belt will briefly hang out of the boom profile. However, this does not constitute a technical malfunction and does not negatively affect the function and service life of the operator.

4.9 Fitting the operator head

- Fix the operator head. See figure 7 on **page 35**.

4.10 Fixing the warning sign

- Fix the crushing warning sign in a prominent, cleaned and degreased place, for example near to the permanently installed button for moving the operator. See figure 8 on **page 35**.

4.11 Install drive control

(See figure 9 on **page 36**)

- Do not operate the control in potentially explosive areas.
- Install the housing max. 8 m from the drive motor.
- To ensure a user-friendly viewing height, a height of approx. 1400mm is recommended for the bottom edge of the housing.
- Install the housing using all of the supplied mounting feet, on an even, vibration-free surface.
- When installing the housing with mounting feet on a steel panel, use the metal screws and washers provided (drill with a diameter of 3.5 mm).
- When installing the housing with mounting feet, e.g. on steel beams, use screws M4 / M5 and corresponding washers.

4.12 Electrically connect the drive/control



DANGER!

Danger! Risk to life due to electrical current!

Contact with the mains voltage presents the danger of a deadly electric shock.

For that reason, observe the following warnings under all circumstances:

- ▶ Electrical connections may only be made by a qualified electrician.
- ▶ The on-site electrical installation must conform to the applicable protective regulations (230 / 240 V AC, 50 Hz)!
- ▶ Disconnect the mains plug and the plug of the emergency battery whenever performing work on the door system.



ATTENTION!

Please note! Observe the following points for all electrical work:

- Electrical connections may only be made by a qualified electrician.
- The on-site electrical installation must conform to the applicable protective regulations (230 / 240 V AC, 50 Hz)!
- Disconnect the mains plug and the plug of the emergency battery whenever performing work on the door system.
- To avoid malfunctions, ensure that the control lines of the drive (24 V DC) are laid in an installation system separate from the other supply lines (230 V AC)!*
- The customer must not shorten or extend the connection line provided.*

4.12.1 Connecting the connection line for the opener/control board

(See figure 10 on **page 36** and figure 11 on **page 37**)

- Connect the supplied connection cable to the opener (see figure 10) and the control board (see figure 11).
- After inserting the connection cable into the control board housing, push the end of the sheathing approx. 10 mm to one side, connect the shielding braid of the connection cable to the earthing clamp and plug in the protective earth (see figure 11).

4.12.2 Mains connection

Connect the mains supply line on the control board side (see Figure 11 on **page 37**).

Establish the connection with the mains as follows:

Via socket:

- The plug on the mains connection line is an all-pole mains disconnection device. The socket for this plug must be installed at a child-safe, but easily accessible height (between 1.5 m and 1.9 m) to enable disconnection from the mains if necessary. If this is not possible, the supply line to this socket must be equipped with a lockable, all-pole isolating main switch that must also satisfy the aforementioned criteria.
- Install the socket for the power supply to the control board next to the control board housing, at a distance of approx. 50 cm.

Permanent mains connection:

- With a permanent connection, install a lockable and all-pole isolating main switch at a child-safe, but easily accessible height (between 1.5m and 1.9m) to enable disconnection from the mains if necessary.

4.12.3 Additional work during installation in conjunction with the traffic light control MS3EB-G (red/green):

(See figure 12 and figure 13 on **page 38**)

- Flange mount the housing for the traffic light control on the opener control housing.
- Fasten the traffic light control inside the control board housing with the assembly materials provided.
- Plug the connection line (signal line) provided into the opener control and the traffic light control.
- Connect the supply line (mains) to the opener control and the traffic light control.

5 INITIAL START-UP

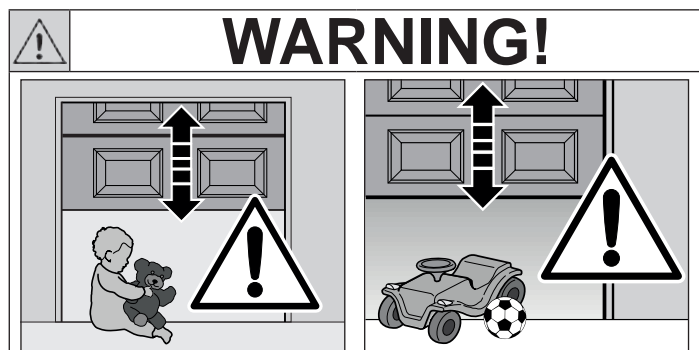

WARNING!

Danger of injury during door travel!

If people or objects are in the area around the door while the door is in motion, this can lead to injuries or damage.

- ▶ Children are not allowed to play near the door system.
- ▶ Make sure that no persons or objects are in the door's area of travel.
- ▶ If the door system has only one safety feature, only operate the garage door operator if you are within sight of the door's area of travel.
- ▶ Monitor the door travel until the door has reached the end-of-travel position.
- ▶ Only drive or pass through remote control door systems if the door is in the Open end-of-travel position!
- ▶ Never stay standing under the open door.

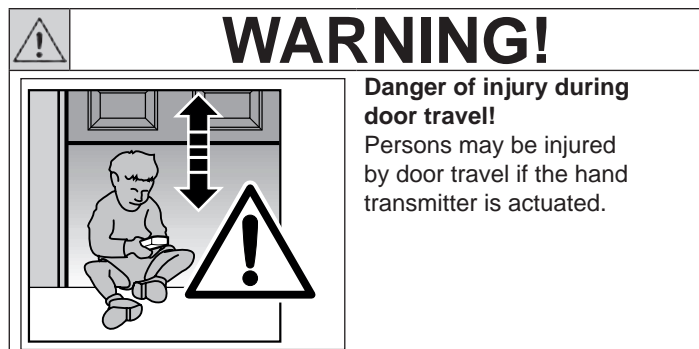

WARNING!

Danger of injury during door travel!

Persons may be injured by door travel if the hand transmitter is actuated.

- ▶ Make sure that the hand transmitters are kept away from children and can only be used by people who have been instructed on how the remotecontrol door functions!
- ▶ If the door has only one safety device, only operate the hand transmitter if you are within sight of the door!
- ▶ Only drive or pass through remote control door systems if the door is in the Open end-of-travel position!
- ▶ Never stay standing under the open door.
- ▶ Please note that unwanted door travel may occur if a hand transmitter button is accidentally pressed (e.g. if stored in a pocket / handbag).

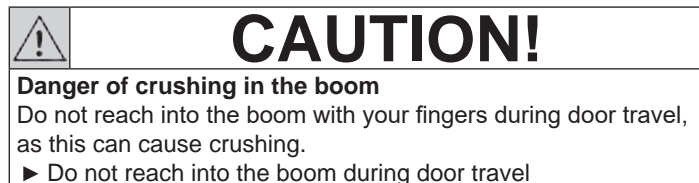

CAUTION!

Danger of crushing in the boom

Do not reach into the boom with your fingers during door travel, as this can cause crushing.

- ▶ Do not reach into the boom during door travel

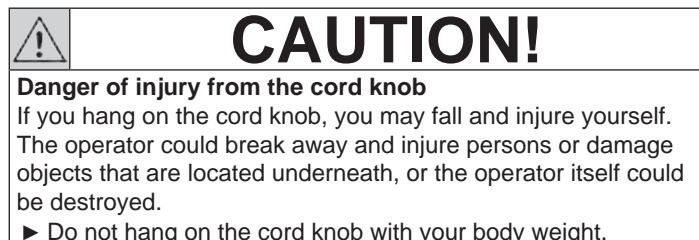

CAUTION!

Danger of injury from the cord knob

If you hang on the cord knob, you may fall and injure yourself. The operator could break away and injure persons or damage objects that are located underneath, or the operator itself could be destroyed.

- ▶ Do not hang on the cord knob with your body weight.







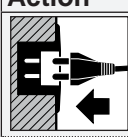

ATTENTION!

- External voltage on the connecting terminals of the control will destroy the electronics!
- To prevent malfunctions: Duct the operator's connection cables (24 V DC) in an installation system that is separate from other supply lines (230 V AC)!

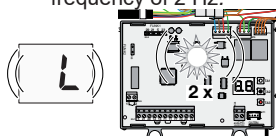
5.1 Teaching in the operator

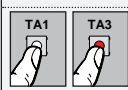
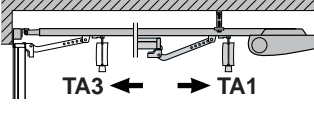
When teaching in, the operator is adjusted to the door. The travel length, required force for opening and closing, and any connected safety devices are automatically taught in and saved in a power failure-proof manner. The data is only valid for this door.

Action	Display / Info
 <p>Insert mains plug.</p>	<p>The software version is displayed</p>
 <p>Hold down button TA2 for ~6 sec...</p>	<p>...until L flashes on the display. The control lighting flashes at frequency of 2 Hz.</p> 
 <p>Release button TA2.</p>	
 <p>Hold down button TA3 or TA1, to move the door to the desired "OPEN DOOR" position. In its „OPEN“ position the door must maintain a minimum distance of approx. 50 mm to its limit stop.</p> <p>→ deadman function, see <i>Learning mode, 10.3 on page 17</i>.</p>	 <p>CLOSE door OPEN door</p>
 <p>Briefly press button TA2 once.</p>	<p>The learning process begins; the door closes, opens and then closes another 2x automatically. After 5 learning movements, the control lighting switches on and the opener moves the door to the Door Open end position.</p>

Programming is complete.





WARNING!

Because the power shut down does not function during the teaching process, it is essential that the installer remains at the device to prevent anyone from getting close to the door.

5.2 Teaching in the Partial opening function

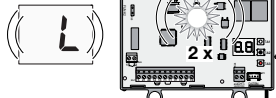
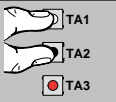
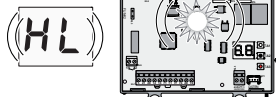
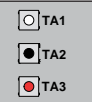
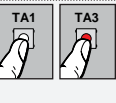
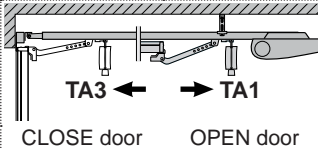
The opener is taught in and in the Door Closed end position.

Action	Display / Info
 <p>Hold down button TA2 for ~6 sec...</p>	<p>...until L flashes on the display. The control lighting flashes at frequency of 2 Hz.</p> 
 <p>Hold down button TA2 in addition to TA1...</p>	<p>...until HL flashes on the display. The control lighting flashes slowly.</p> 
 <p>Release button TA1 and TA2.</p>	
 <p>Hold down button TA3 or TA1, to move the door to the desired "PART OPEN" position.</p> <p>→ deadman function, see <i>Learning mode</i>, 10.3 on page 17.</p>	 <p>CLOSE door OPEN door</p>
 <p>Briefly press button TA2 once. The PART OPEN position is saved.</p>	

The Part OPEN position is programmed.

5.3 Deleting door data

If the teaching process is not completed successfully despite several attempts, we recommend resetting the imported data as follows:

1. Remove the mains plug and wait at least 10 seconds.
2. Insert the mains plug again.
3. After the seven segment display has switched on, press the black TA2 button within the next 5 seconds and then the white TA1 button; keep these buttons depressed until the control lighting begins to flash three times.
4. Release the button; after the software version is displayed, „L“ flashes on the display.
5. All data is now deleted.

Note

In the supplied state, the door data is deleted and the drive may be taught immediately.

6 INSTALL ACCESSORIES



DANGER!

Danger! Risk to life due to electrical current!

Contact with the mains voltage presents the danger of a deadly electric shock.

For that reason, observe the following warnings under all circumstances:

- ▶ Electrical connections may only be made by a qualified electrician.
- ▶ The on-site electrical installation must conform to the applicable protective regulations (230 / 240 V AC, 50 Hz)!
- ▶ Disconnect the mains plug and the plug of the emergency battery whenever performing work on the door system.



ATTENTION!

Please note! Observe the following points for all electrical work:

- Electrical connections may only be made by a qualified electrician.
- The on-site electrical installation must conform to the applicable protective regulations (230 / 240 V AC, 50 Hz)!
- Disconnect the mains plug and the plug of the emergency battery whenever performing work on the door system.
- To avoid malfunctions, ensure that the control lines of the drive (24 V DC) are laid in an installation system separate from the other supply lines (230 V AC)!
- The customer must not shorten or extend the connection line provided.

6.1 Electrical connection / Connection terminals

(see „Circuit board overview MS550“ on page 13)

- ▶ The connection terminals can be accessed by opening the inspection window. The terminals that the additional components are connected to, such as volt-free internal push buttons, key switches or photocells, only carry a non-hazardous low-voltage current of approx. 24 V DC.
 - ▶ All connecting terminals can be given multiple assignments, but with a maximum of. 1 x 1,5 mm².
 - ▶ Connection terminal KL1 is removable.
- ⚠ **The mains plug must be disconnected before any work is performed on the operator!**

Note

Loading of the operator by all accessories: 200 mA.

6.2 External receiver

- ▶ Plug radio receiver into the 4-pin base (**FUNK 1**), see „Circuit board overview MS550“ on page 13.
 - terminal 20 → 0 V
 - terminal 21 → Channel 1
 - terminal 23 → Channel 2
 - terminal 5 → +24 V

⚠ **The connector must engage properly!**

- ▶ See the manual of the receiver for information on teaching in the remote control buttons to the receiver.

Note

The function of Channel 2 (terminal 23) can be set in menu 7, see page 16.

6.3 External impulse button

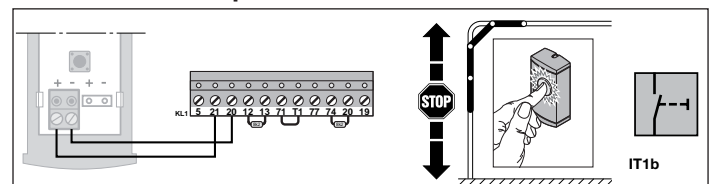

Impulse button

Connect the button (potential-free make contact, e.g. inwards or key switch) as follows:

- ▶ First contact → terminal 21 (pulse input).
 - ▶ Second contact → terminal 20 (0 V).
- Connect multiple buttons in parallel!

6.4 Wicket door contact / Stop contact

6.4.1 Wicket door contact

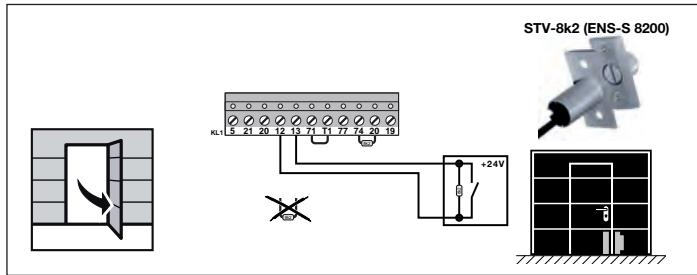

Wicket door contact

Connect a wicket door contact with 8k2 resistor (STV-8k2/ENS-S 8200) to stop the drive as follows:

- ▶ Remove the 8k2 resistor on terminals 12 and 13.
- ▶ Connect the wicket door contact to terminal 12 (stop input) and terminal 13 (+24 V).

Note

The wicket door contact (8.2 kΩ, ± 10%) must fulfil **Cat.2 PL c** per **EN 13849-1**.

Breaking the contact stops any door movements which are in progress immediately and permanently prevents further movements.

Control lighting flashes 1x, display → error code **05**.

6.4.2 Stop contact

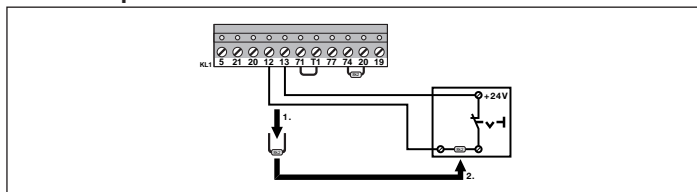

Stop contact

Connect off switches or stop contacts (they must be positive break contacts) to stop the opener (stop or emergency stop circuit) as follows:

- ▶ Remove the 8k2 resistor on terminals 12 and 13.
- ▶ Connect the 8k2 resistor in the off switch in series with the potential-free break contact of the off switch.
- ▶ Connect the supply line of the off switch to terminal 12 (stop input) and terminal 13 (+24 V).

Note

Breaking the contact stops any door movements which are in progress immediately and permanently prevents further movements.

Control lighting flashes 1x, display → error code **05**.

6.5 Contact photocell for safety recoil

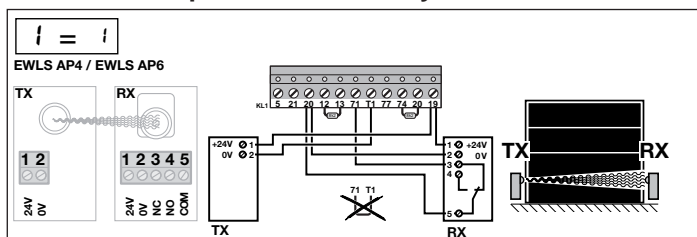

Contact photocell

- ▶ Remove wire jumper between terminals T1 and 71.
- ▶ **Connect potential-free break contact of the receiver** to terminal 71 (safety input) and terminal 20 (0 V).
- ▶ **Connect power supply of the transmitter** to terminal 19 (approx. +24 V, switched off in standby mode) and terminal T1 (0 V with test).
- ▶ **Connect power supply of the receiver** to terminal 19 (approx. +24 V, switched off in standby mode) and terminal 20 (0 V).
- ▶ Menu **1** must be set to **1**.

Note

If the light barrier is interrupted during the “Close door” run, a reversal in “open” direction occurs.

The light barrier is only active during “Close door”. Control lighting flashes 1x, display → error code **08**.

With automatic closing set, the duration of the keep open time after the light barrier area has been vacated is determined by the setting in menus **H** and **J**.

The light barrier is tested in the “Door open” end position, each time before it starts to move in the Close direction. If the light barrier test is unsuccessful, closing is prevented.

Control lighting flashes 1x, display → error code **38**.

The error message can be acknowledged by repeating the command, and after the keep open time has elapsed or another command in the Close direction is received, another attempt is made to close the door.

If no light barrier is connected, the wire jumper must be connected between T1 and 71 and menu **1** should be set to **1**.

6.6 Two-wire photocell for safety recoil

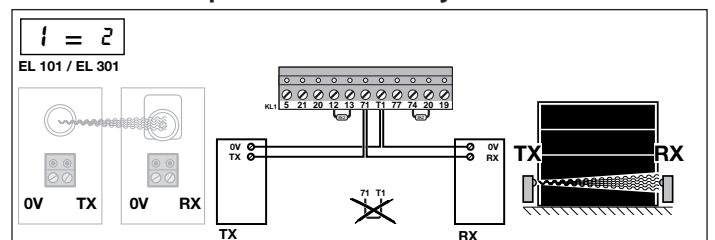

2-wire photocell EL101 oder EL301

- ▶ Remove wire jumper between terminals T1 and 71.
- ▶ Connect light barrier connection RX or TX to terminal 71 (safety input).
- ▶ Connect light barrier connection 0V to terminal T1 (0 V).
- ▶ Menu **1** must be set to **2**.

Note

If the light barrier is interrupted during the “Close door” run, a reversal in “open” direction occurs.

The light barrier is only active during “Close door”. Control lighting flashes 1x, display → error code **08**.

With automatic closing set, the duration of the keep open time after the light barrier area has been vacated is determined by the setting in menus **H** and **J**.

If no light barrier is connected, the wire jumper must be connected between T1 and 71 and menu **1** should be set to **1**.

6.7 Closing edge safety device 8k2

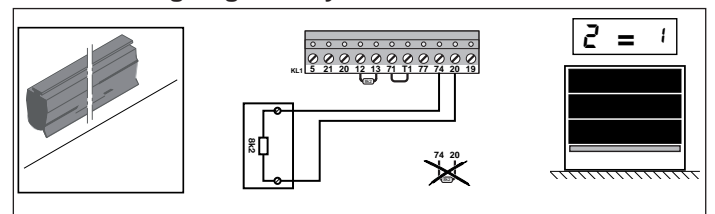

8k2 closing edge safety device

- ▶ Remove the 8k2 resistor on terminals 74 and 20.
- ▶ Connect the closing edge safety device to terminal 74 (safety input) and terminal 20 (0 V).
- ▶ Menu **2** must be set to **1**.

Note

The input is active during the door's "CLOSE" and "OPEN" movements. During closing, a reversal of direction occurs, moving the door back to its "OPEN" end position. The control lighting issues the flash 1x pulse code, and the display shows error code 09. During opening, there is an obstacle clearance of ~ 50 mm. Control lighting flashes 1x, display → error code 32.

If the 8k2 safety edge is active while the door is opening from the "CLOSED" end position, it is only polled after approx. 50 mm, resulting in an immediate stop. Control lighting flashes 1x, display → error code 32.

If no closing edge safety device is connected, the 8k2 resistor must be connected between terminal 20 and 74 and menu 2 should be set to 1.

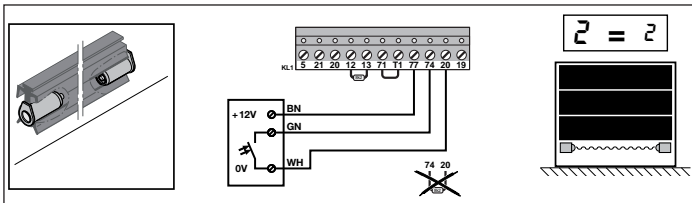
6.8 Optical closing edge safety device**Optical sensors**

- ▶ Remove the 8k2 resistor on terminals 74 and 20.
- ▶ Connect the closing edge safety device to terminal 74 (GN / safety input), terminal 20 (WH / 0 V) and terminal 77 (BN / + 5V).
- ▶ Menu 2 must be set to 2.

Note

The input is active during the door's "CLOSE" movement. During closing, a reversal of direction occurs, moving the door back to its "OPEN" end position, when the closing edge safety device is interrupted.

Control lighting flashes 1x, display → error code 24.

If no closing edge safety device is connected, the 8k2 resistor must be connected between terminal 20 and 74 and menu 2 should be set to 1.

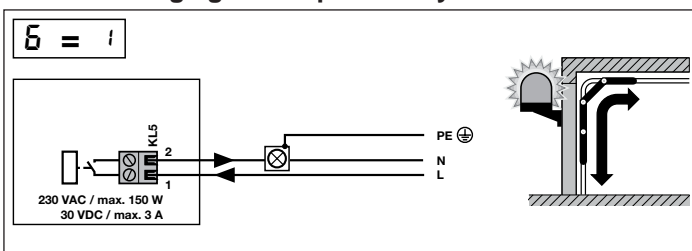
6.9 Warning light via option relay**Warning light via option relay**

A warning light can be controlled via the potential-free make contact (KL 5) of the option relay.

- ▶ 230 VAC, max. 150 W (ohmic load)
- ▶ 30 VDC, max. 3 A (ohmic load)

- ▶ The warning light is actuated each time the door moves, and during the advance warning period. The function of the warning light (light up-flash-OFF) can be set in menu „d“.
- ▶ Menu 5 must be set to 1.

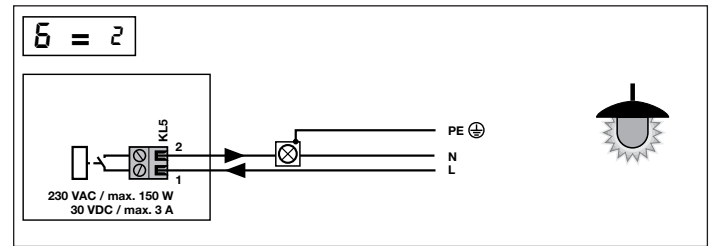
6.10 External lamp via option relay**External lamp via option relay**

An additional external lamp can be controlled via the potential-free make contact (KL 5) of the option relay.

- ▶ 230 VAC, max. 150 W (ohmic load)
- ▶ 30 VDC, max. 3 A (ohmic load)

- ▶ The function of the lamp (lighting duration) can be selected in menu „b“.
- ▶ Menu 5 must be set to 2.

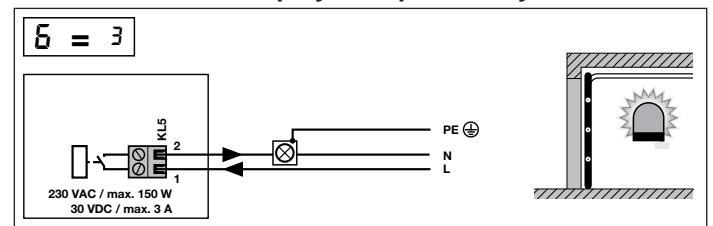
6.11 Close Door display via option relay**Close Door display via option relay**

An external Close Door display can be controlled via the potential-free make contact (KL 5) of the option relay.

- ▶ 230 VAC, max. 150 W (ohmic load)
- ▶ 30 VDC, max. 3 A (ohmic load)

- ▶ The option relay is actuated in the "Door closed" end position.
- ▶ Menu 5 must be set to 3.

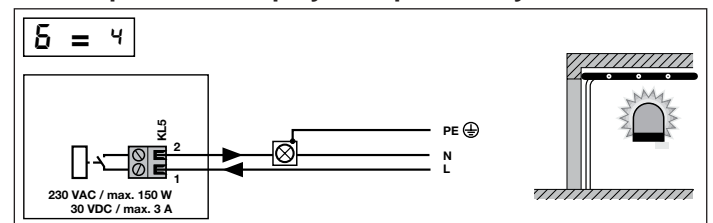
6.12 Open Door display via option relay**Open Door display via option relay**

An external Open Door display can be controlled via the potential-free make contact (KL 5) of the option relay.

- ▶ 230 VAC, max. 150 W (ohmic load)
- ▶ 30 VDC, max. 3 A (ohmic load)

- ▶ The option relay is actuated in the "Door open" end position.
- ▶ Menu 5 must be set to 4.

6.13 Light output 24 VDC

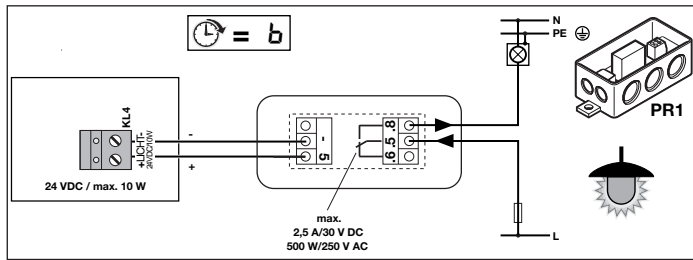

Light output 24 VDC

The optional relay PR1 can be connected to the light output (terminal KL4).

- ▶ The function of the external lamp can be selected in menu **b**.



ATTENTION!

*Do not load 24 VDC light output with more than 10 W!
Overloading the output will cause the electronics to be destroyed!!*

6.14 Timer contact for Permanently Open command

Connect a timer output with potential-free make contacts as follows:

- ▶ First contact → terminal 21 (timer input)
- ▶ Second contact → terminal 20 (0 V)

Note

The function "Permanent Open" is only available when automatic closing is selected.
Set the keep open time in menu **E**, and prewarning period in menu **F**.





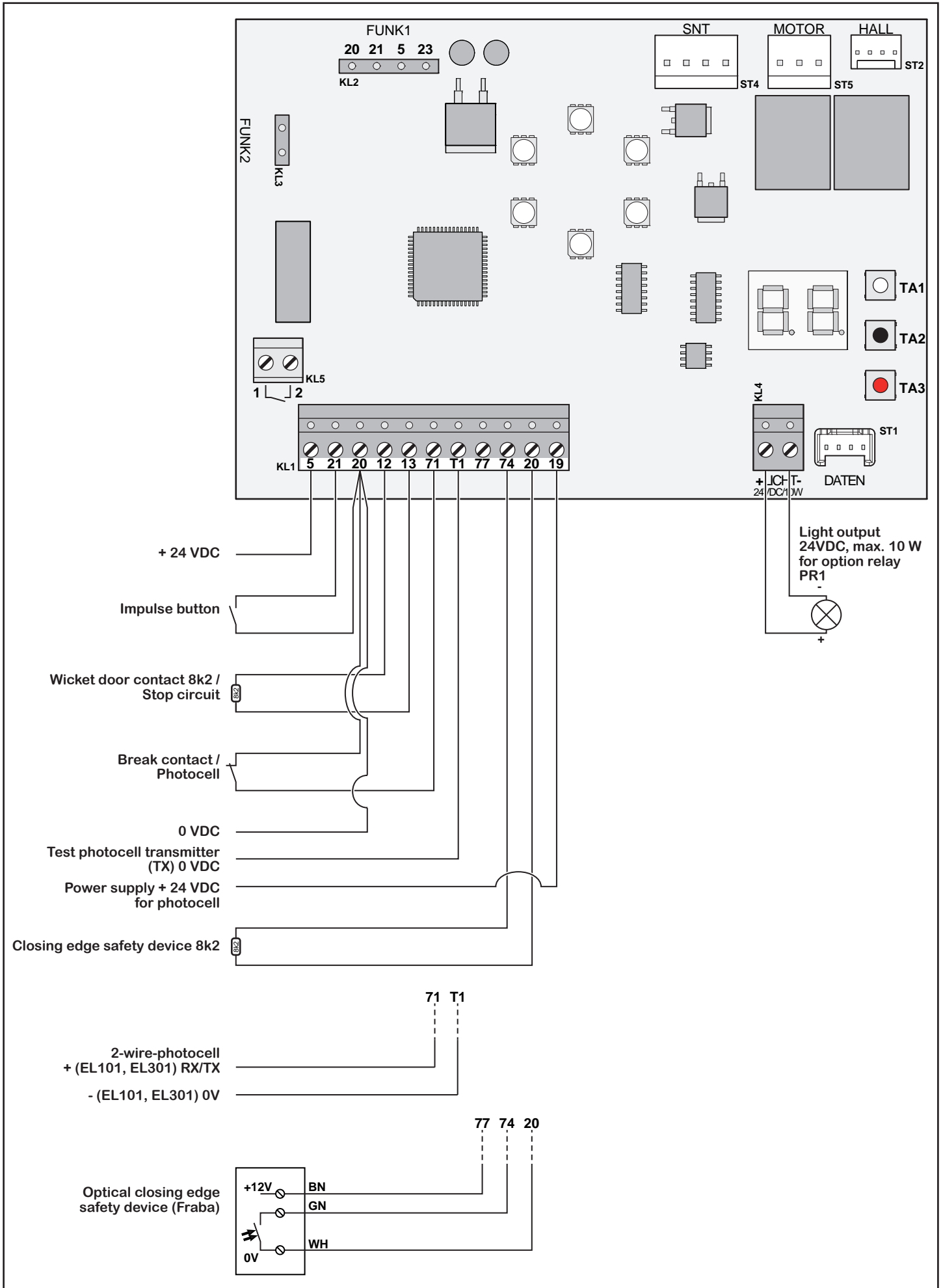





When traffic light control MS3EB-G is connected, connect the timer to terminals 20/21 (Permanent Open with "preferred direction *outwards*") or 20/24 (Permanent Open with "preferred direction *inwards*") on the traffic light control.

7 CIRCUIT BOARD OVERVIEW MS550

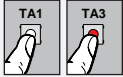

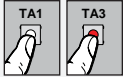
8 CONTROL SYSTEM MS550

8.1 Operate menu control system MS550

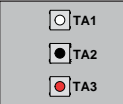













Action	Display / Info
 <p>Hold down button TA2 for ~3 sec. until 11 or 12 appears on the display.</p>	<p>e.g. </p> <p>Menu item = left digit, <i>notflashing</i> Setting = right digit, <i>flashing</i> You are in the menu selection window.</p>
<p>► Open menu item / Change settings</p>	
 <p>Press button TA3 or TA1 to switch to the desired menu item.</p>	<p>Order of the menus, see „Menu overview“ on page 16.</p>
 <p>Press button TA2. → <i>The menu item is selected.</i></p>	<p>The set value is displayed.</p>
 <p>Press button TA1 or TA3 to change the menu setting.</p>	<p>Menu settings, see „Menu overview“ on page 16.</p>
 <p>Press button TA2 again to exit the menu item.</p>	<p>You are back in the menu selection window.</p>
<p>☞ Repeat this section, if you wish to make further changes in the menus.</p>	
<p>► Save changes in the menus / Exit the menus</p>	
 <p>Select menu item 0 with button TA3 or TA1.</p>	
 <p>Hold down button TA2 for ~3 sec.</p>	<p>Successful saving is indicated on the display by</p> 
 <p>Release button TA2.</p>	<p>The status of the door is displayed, see 10.4 on page 17.</p>
<p>☞ If button TA2 is only pressed briefly or no button is pressed for 60 sec., programming mode exits without saving the changes.</p>	

Note















 The red button **TA3** can only be used during the teaching in and the programming modus. If the red button **TA3** is used during the normal functioning mode, **r 1/r2/r3** or **r4** appear on the display. In this case press the red button **TA3** several times until the door position is shown on the display, see **10.4 on page 17.**

8.2 Example for a menu change

8.2.1 Activation of the fast opening function

Action	Display / Info
 <p>Hold down button TA2 for ~3 sec. until 11 or 12 appears on the display.</p>	<p>e.g. </p>
 <p>Press button TA1 (2x) to switch to the menu 3.</p>	
 <p>Press button TA2. → <i>The menu item is selected.</i></p>	
 <p>Press button TA1 or TA3 to change the menu setting.</p>	
 <p>Press button TA2 again to exit the menu item.</p>	
 <p>Press button TA3 (3x) to select menu item 0.</p>	
 <p>Hold down button TA2 for ~3 sec.</p>	<p>Successful saving is indicated on the display by</p> 
 <p>Release button TA2.</p>	<p>The status of the door is displayed, see 10.4 on page 17.</p>



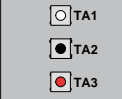



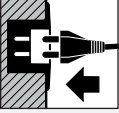

8.2.2 Activate automatic closing with a keep open time of 60 seconds:

Action	Display / Info
 <p>Hold down button TA2 for ~3 sec. until 11 or 12 appears on the display.</p>	<p>e.g. </p>
 <p>Press button TA1 (13x) or TA3 (8x) to switch to menu item E.</p>	
 <p>Press button TA2. → <i>The menu item is selected.</i></p>	
 <p>Press button TA1 (5x) or TA3 (5x) to change the menu setting to 5.</p>	
 <p>Press button TA2 again to exit the menu item.</p>	
 <p>Press button TA1 (7x) or TA3 (14x) to select menu item 0.</p>	
 <p>Hold down button TA2 for ~3 sec.</p>	<p>Successful saving is indicated on the display by</p> 
 <p>Release button TA2.</p>	<p>The status of the door is displayed, see 10.4 on page 17.</p>

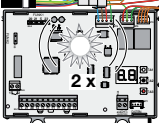
9 SPECIAL FUNCTIONS

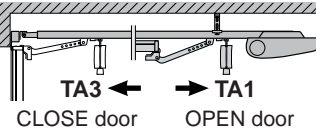
9.1 Suppressing the light barrier

After everything is installed and connected, the drive is taught (position of the light barrier, track, power for opening and closing).

Action	Display / Info
 Insert mains plug.	The software version is displayed
 Hold down button TA2 for ~6 sec...	...until L flashes on the display. The opener light flashes at frequency of 2 Hz.  
 Release button TA2 .	
 Hold down button TA3 or TA1 , to move the door to the desired "OPEN DOOR" position. In its „OPEN“ position the door must maintain a minimum distance of approx. 50 mm to its limit stop. → deadman function , see <i>Learning mode, 10.3 on page 17</i> .	 TA3 ← → TA1 CLOSE door OPEN door
 Briefly press button TA2 once.	The learning process starts; the door closes until it reaches the light barrier position.
 Press the TA1 button within the next 7 seconds and hold it for at least 3 seconds.	The drive light brightens for approx. 1 second to indicate that the position has been saved.
  Release the TA1 button immediately and continue the programming process by pressing the TA1 button briefly.	The teaching process continues; the door closes, opens and then closes another 2x automatically. After 5 learning movements, the opener light switches on and the opener moves the door to the Door Open end position..

Programming is complete.



WARNING!

Because the power shut down does not function during the teaching process, it is essential that the installer remains at the device to prevent anyone from getting close to the door.

Note

The -50 mm position is then taught as the reversal limit at which the drive stopped.

The light barrier position is deleted during the next teaching process. The light barrier position always has to be taught again.



ATTENTION!

The light barrier position must be selected in such a way that a reference block as per EN 12453 is forcibly identified!

9.2 Programming the reversal limit for the advanced light barrier (VL1/VL2)

- ▶ The advanced light barrier is installed and connected; menu **2** is at **3**.
- ▶ Bring the door into the door open end position.
- ▶ Place a rule flat on the floor.
- ▶ Initiate the teaching process; to do this, set the **P** menu to **1** and start the teaching process using the **TA2** button.
- ▶ **3** is shown on the display and the drive moves the door in the closing direction until the advanced light barrier identifies the bar.
- ▶ The drive stops and **4** is shown on the display.
- ▶ The point that has been taught in this way is confirmed by pressing the **TA2** button; the display shows menu item **P** again.
- ▶ Press **0** to exit the menu.
- ▶ The reversal limit is taught and saved.
- ▶ Remove the rule and open the door by pressing the **TA1** button.

The system is now in normal mode again.

10 MENU OVERVIEW

Legend:		☒ = Factory setting	" = Second	' = Minute	KL = Terminal
♣ After making changes in the menu, it is necessary to teach in the opener again!					
0	▶ Always select menu item 0 to save changes in the menus. See also „8.1 Operate menu control system MS550“ on page 14.				
1	Light barrier analysis	☒ 1: Contact photocell	2: Two-wire photocell		
2	Closing edge safety device analysis	☒ 1: 8k2 safety edge	2: OSE (opto-sensor safety edge)	3: VL1/VL2 (leading light barrier)	
3	Opening speed in OPEN direction ♣	☒ 1: Normal speed		2: Quick OPEN	
4	Soft-run speed in CLOSE direction	1: 30%		☒ 2: 50%	
5	Brief reverse at Door CLOSED	0: Off	1 ~3 mm	☒ 2 ~6 mm	3 ~9 mm 4 ~12 mm 5 ~15 mm
6	Option relay function (KL5)	☒ 1: Warning light	2: Light function		3: CLOSE Door display 4: OPEN Door display
7	Input 23 function 4-pin connection / FUNK1(KL2)	☒ 1: Part Open command		2: Light control	
8	Defined choice of direction	☒ 0: No	1 Yes, FUNK1+FUNK2 input		2 Yes, FUNK1 input only
9	Running direction logic ♣	☒ 1: Default // opens towards the opener		2: Gates // closes towards the opener	
R	Opener light and illumination period	0: OPEN 30" - CLOSE 5"	1: OPEN 90" - CLOSE 5"	☒ 2: OPEN 150" - CLOSE 5"	
		3: OPEN 240" - CLOSE 5"	4: OPEN 300" - CLOSE 5"	5: 30"	6: 90"
		7: 150"	8: 240"	9: 300"	R: 5", dimmed
b	Response time of 24 VDC light output or option relay, if menu 6 = 2 (light function) is set!	0: 1"	1: 1'	2: 2'	3: 3' 4: 4' 5: 5'
		6: 10'	7: 15'	8: On/Off	☒ 9: same as opener light (menu R)
⚠ With the On/Off function (menu b = 8) the light can only be switched off when the opener is stationary. If the lighting is switched on, it must be switched off again using a command again.					
c	Activate light function / opener light A = Channel 1 / Input 21 (KL1 / KL2) B = Channel 3 / Input 23 (KL2) → Menu 7 = 2! * The particular light period / function select in the menu is enacted! (only R // R und b // only b)	☒ 1:	A Starts opener + opener light → R* + external light → b*		
			B Only switches on external light → b*.		
		2:	A Starts opener + opener light → R*.		
			B Only switches on external light → b*.		
		3:	A Starts opener + opener light → R* + external light → b*		
			B Switches on opener light + external light → b*		
		4:	A Starts opener + opener light → R*.		
			B Switches on opener light + external light → b*		
⚠ External light relates to light sources connected via KL5 (option relay, if menu 6 = 2) and/or to KL4 (24 VDC, max 10 W).					
d	Option relay function with warning light connected Door movement - Prewarning period - CLOSE door	☒ 2: ON during door movement - FLASHES during prewarning period - OFF during CLOSE Door			
		1: On - On - Off	3: Flashes - On - Off	4: Flashes - Flashes - Off	5: On - On - On
		6: On - Flashes - On	7: Flashes - On - On	8: Flashes - Flashes - On	
e	Keep open time / Automatic closing	☒ 0: No keep open time		1: 10"	2: 20" 3: 30"
		4: 45"	5: 60"	6: 90"	7: 120" 8: 150" 9: 180"
⚠ This function is only permitted if a presence detector is installed as per EN 12453, table 1.					
f	Prewarning period in CLOSE direction	☒ 0: No prewarning period		1: 3"	2: 5" 3: 10"
		4: 15"	5: 20"	6: 30"	7: 40" 8: 50" 9: 60"
h	Reset keep open time after CLOSE light barrier is broken	☒ 1: Keep open time is reset and starts again.			
		2: Keep open time is not reset → Remaining time elapses. Reset occurs if the light barrier is interrupted during the prewarning period.			
j	Quick Close after CLOSE light barrier is broken	☒ 0: Off	1: Quick Close after 1" prewarning period	2: 2"	3: 3"
		4: 4"	5: 5"	6: 6"	7: 7" 8: 8" 9: 9"
⚠ This function is only active if the intake is automatic.					
n	Reversing behaviour for force shutdown in Close direction	1: Obstacle clearance as far as Door OPEN end position (with AUTO CLOSING selected)			
		☒ 2: 300 mm obstacle clearance in OPEN Door direction			
p	Teach in a leading light barrier (VL1/VL2)	☒ 0: Do not teach in light barrier			
		1: Teach in light barrier			
⚠ The teaching process can only be carried out if the advanced light barrier is activated (menu 2 = 3).					
Exit menu:					
▶ Using button TA1 or TA3, select menu item 0 → Display 0					
▶ Hold down button TA2 for ~ 3" → Display 5t for ~3", then door status display. The changes are saved.					

10.1 Functional examples

Requested function	Required setting (different from factory setting)
Defined OPEN/CLOSE command via radio	Menu 8 = 1 Teach the OPEN transmitter button on channel 1 and CLOSE transmitter button on channel 2.
The external lighting connected to the KL5 option relay should be activated via a separate on/off radio command (outlet KL4 (24VDC/10W) activates in parallel)	Menu 6 = 2 , Menu 7 = 2 , Menu b = 8 Teach the „Light“ transmitter button on channel 2.
The integrated LED lighting should be activated via a separate on/off radio command (outlet KL4 (24V DC/10W) activates in parallel)	Menu b = 8 , Menu 7 = 2 , Menu c = 4 Teach the „Light“ transmitter button on channel 2.
The external lighting at KL 4 (24VDC/10W) should be activated via a separate on/off radio command	Menu 7 = 2 , Menu b = 8 Teach the „Light“ transmitter button on channel 2.
Wipe pulse (1 second) through KL 5 option relay via separate radio command (e.g. control external drive), note: KL 4 can no longer be controlled separately	Menu 6 = 2 , Menu 7 = 2 , Menu b = 0 , Menu c = 2 Teach the „Wipe pulse“ transmitter button on channel 2.
Wipe pulse at drive start command via option relay KL 5	Menu 6 = 2 , Menu b = 0
Red light on KL5 (warning function), wipe pulse on KL4 (24V DC/10W) (for potential-free pulse at KL4: Relay PR 1 required)	Menu b = 0

10.2 Command inputs (shown on the display)





12	Signal from circuit board button TA1
21	Input/Channel 1 (Terminal 21, FUNK1) activated
21	“Outwards” request, only with traffic light control MS3EB-G connected

21	Command button, terminal 20/21 activated
23	Input/Channel 2 (Terminal 23, FUNK1) activated
24	“Inwards” request, only with traffic light control MS3EB-G connected

10.3 Functions of circuit board buttons TA1 and TA3:

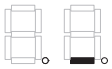
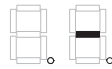
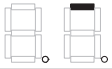
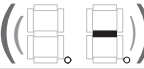
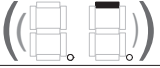
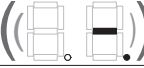
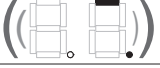

For ↓	Button TA1	Button TA3
Pulse operation	→ <i>Open / Stop / Close / Stop, etc.</i>	
Defined choice of direction		
Auto-closing selected	→ <i>Open (not with door in “Door open” end position !)</i> → <i>The keep open time is interrupted in the “Door open” end position; after the prewarning period has elapsed (menu F) the door closes</i>	
Changes in menus	→ <i>Scroll up (0, 1, 2...)</i>	→ <i>Scroll down (... 2, 1, 0)</i>
Learning mode	→ <i>Deadman Open function</i>	→ <i>Deadman Close function</i>

10.4 Status display

 Door in Closed end position	 Door in intermediate position
 Door in Open end position	 Opener in motion
 Open end position, keep open time running	 Intermediate position, prewarning period running
 Open end position, prewarning period running	 Part Open end position < 50 cm (with/without auto-closing selected) Part Open end position > 50 cm (auto-closing not selected)
 Part Open end position > 50 cm (auto-closing is selected)	 Part Open end position (prewarning time running)
 No door parameters, teach in the opener	

11 ERROR TABLE

Display (flashes)	Light / Warning lamp	Error / Warning	Possible cause	Remedy
01	Flashes 4x	Interruption of learning / reference run via operating button or timeout.	A command device was actuated during the learning/reference run.	Restart the learning/reference run, however no not actuate any command devices.
			No button has been pressed in learning mode for longer than 60 sec.	Restart the learning/reference run.
02	Flashes 4x	Timeout Hall pulse, control system not receiving Hall pulse.	Hall cable defective.	Check Hall cable, replace if necessary.
			Hall sensor defective.	Replace opener.
			Control system defective.	Replace opener or control system.
03	Flashes 4x	Too many Hall pulses with motor stopped. Motor being pulled or pushed.	Door open too wide.	Correct Door Open end position.
			Spring compensation not OK	Check spring compensation, and correct or replace if necessary.
04	Flashes 4x	Error on the Hall sensor.	Hall cable defective, short-circuit Channel 1 and Channel 2.	Check Hall cable, replace if necessary.
			Hallsensor defekt.	Replace motor or opener.
05	Flashes 1x	Wicket door contact was activated.	Stop or Emergency Stop circuit at terminals 12 and 13 was interrupted or broken during a door movement, see „6.4 Wicket door contact / Stop contact“ on page 10.	Make Stop or Emergency Stop circuit.
			☛ When there is no wicket door or Emergency Stop circuit connected, an 8k2 resistor must be connected between terminals 12 / 13 .	
06	Flashes 4x	Motor runtime too long.	Max. runtime of 140 sec. was insufficient for the movement.	Reduce movement length.
			Toothed belt cracked.	Replace toothed belt.
			Opener defective.	Replace opener.
07	Flashes 4x	Door movement too short for path learning.	The movement path being taught in is < 600 mm.	Correct movement path; teach in opener again.
08	Flashes 1x	CLOSE light barrier was activated.	Light barrier at terminals 20 and 71 was interrupted or activated.	Remove obstacle which triggered the light barrier and/or check or if necessary replace the light barrier.
			Incorrect analysis selected for the connected light barrier. See chapter „6.5 Contact photocell for safety recoil“ on page 10 and „6.6 Two-wire photocell for safety recoil“ on page 10.	
☛ Without light barrier connected (Terminals 20 / 71), menu 1 should be set to 1 and a wire jumper must be connected between terminals T1 / 71 .				
09	Flashes 1x	CLOSE safety contact edge was activated.	Closing edge safety device (8k2) at terminals 20 and 74 was interrupted or activated, see „6.7 Closing edge safety device 8k2“ on page 10.	Remove obstacle which triggered the closing edge safety device and/or check or if necessary replace the closing edge safety device / supply line.
			☛ With the closing edge safety device connected (Terminals 20 / 74), menu 2 should be set to 1 and an 8k2 resistor must be connected between terminals 20 / 74.	
10	Flashes 4x	Motor current exceeded.	The taught-in current was exceeded due to a defective door mechanism or broken spring.	Check door mechanism and/or springs and repair.
11	Flashes 4x	Too many Hall pulses.	You are attempting to teach in a movement path which has more than 8500 pulses (approx. 8500 mm).	Correct movement path; teach in opener again.
12	Flashes 4x	Relay sticking.	Motor relay of the opener control system sticking.	Replace control system.
13	Flashes 4x	Door position absent after restart.	The current position of the door is no longer recognised after a power cut.	Perform reference run, see 12 on page 20.
14	Flashes 4x	Invalid door position at restart.	The current position of the door during a learning or reference run is no longer recognised after a power cut.	Teach in opener again or perform reference run again. If the error occurs multiple times, replace the control system.
15	Flashes 4x	Error during testing of the 8k2 safety edge.	Test of closing edge analysis (8k2) was unsuccessful. Closing edge safety device 8k2 was activated during testing.	Inspect closing edge safety device / supply line, and replace if necessary.
16	Flashes 4x	Incorrect program operating status.	External interference (current peaks, overvoltage, or similar).	Perform reference run, see 12 on page 20. If the error occurs multiple times, replace the control system.
17	Flashes 4x	Error when indexing the force shutdown.	Internal error.	If the error occurs multiple times, replace the control system.
18	Flashes 3x	Door parameters were deleted manually by the operator.	Door parameters (force and path data) were deleted or the opener has not been taught in yet (this is only information and not an error).	Teach in the opener again, see „5.1 Teaching in the operator“ on page 8.
U				
19	Flashes 4x	Error measuring current.	Motor connection cable defective.	Check motor connection cable, replace if necessary.
			Motor defective.	Replace opener.
			Power supply defective.	Replace opener or power supply
			Control system defective.	Replace opener or control system.

Display (flashes)	Light / Warning lamp	Error / Warning	Possible cause	Remedy
20		Force shutdown during Open door run.	The door is running sluggishly / unevenly.	Correct the door travel.
			There is an obstacle in the door area.	Remove obstacle, teach in opener again if necessary.
21		Operation and learning buttons selected at the same time.	Permanent pulse from an externally connected button during the teach-in process.	Replace the defective button, teach in the opener again, see „5.1 Teaching in the operator“ on page 8.
22	Flashes 2x	2 x force shutdown in succession during Open Door run. Error display only if autoclosing is selected.	The door is running sluggishly or unevenly.	Correct the door travel.
			There is an obstacle in the door area.	Remove obstacle, teach in opener again if necessary. The opener must be restarted with a command.
23	Flashes 4x	Manual reference run started via remote.	The taught-in remote control button was held down for at least 7 sec.	Perform reference run, see 12 on page 20.
24	Flashes 1x	“CLOSE” optical safety contact edge was activated.	An optical closing edge safety device (Fraba), connected to terminals 20, 74 and 77, was interrupted or activated, see „6.8 Optical closing edge safety device“ on page 11. Incorrect analysis selected for the connected closing edge safety device.	Remove the obstacle which triggered the closing edge safety device and/or check or if necessary replace the closing edge safety device / supply line.
			 With the closing edge safety device connected (Terminals 20 / 74 / 77), menu 2 should be set to 1 and an 8k2 resistor must be connected between terminals 20 / 74.	
25	Flashes 4x	Error during speed measurement.	Wicket door contact on the motor connection cable or internal error.	Inspect motor connection cable and replace if necessary. If the error occurs multiple times, replace the control system.
			Power supply defective.	Replace opener or power supply
26		Force shutdown during Close door run.	Door is running sluggishly or unevenly.	Correct the door travel.
			There is an obstacle in the door area.	Remove obstacle, teach in opener again if necessary.
27	Flashes 2x	2x force shutdown or 8k2/OSE in succession during Close Door run. Error display only if autoclosing is selected.	Door is running sluggishly or unevenly.	Correct the door travel.
			There is an obstacle in the door area.	Remove obstacle, teach in opener again if necessary. The opener must be restarted with a command.
			The closing edge safety device is defective.	Inspect closing edge safety device, replace if necessary. The opener must be restarted with a command.
28	Flashes 4x	Current calibration inaccurate.	Internal error.	Replace control system.
29	Flashes 4x	Error with Hall counter value.	External interference, e.g. current peaks, overvoltage, or similar.	If the error occurs multiple times, replace the control system.
30		Reset by watchdog.	Internal error.	If the error occurs multiple times, replace the control system.
32	Flashes 1x	Safety contact edge 8k2 was activated during OPEN.	An closing edge safety device (8k2), connected to terminals 20 and 74, was interrupted or activated, see „6.7 Closing edge safety device 8k2“ on page 10.	Remove obstacle which triggered the closing edge safety device and/or check or if necessary replace the closing edge safety device / supply line.
			 With the closing edge safety device connected (Terminals 20 / 74 / 77), menu 2 should be set to 1 and an 8k2 resistor must be connected between terminals 20 / 74.	
34	Flashes 1x	Safety contact rail was activated during OPEN.	An optical closing edge safety device (Fraba) is connected to terminals 20, 74, and 77, but the incorrect analysis was selected. See „6.8 Optical closing edge safety device“ on page 11.	Select the correct analysis for the connected closing edge safety device. In menu 2 set the value 2.
35	Flashes 2x	Safety device (8k2) was activated 2x in succession during Open Door run.	The closing edge safety device is defective, error display only if auto-closing is selected.	Inspect closing edge safety device, replace if necessary. The opener must be restarted with a command.
			There is an obstacle in the door area; error display only if auto-closing is selected.	Remove obstacle. The opener must be restarted with a command.
38	Flashes 1x	Error while testing the contact light barrier in CLOSE direction.	The test of the contact light barrier for the “Close” direction was unsuccessful.	Inspect light barrier and supply line of the light barrier, replace if necessary.
			Two-wire light barrier is connected.	In menu 1 set the value 2, see „6.6 Two-wire photocell for safety recoil“ on page 10.
46		Reset by watchdog.	Internal error.	If the error occurs multiple times, replace the control system.

Display (flashes)	Light / Warning lamp	Error / Warning	Possible cause	Remedy
47		Error, measurement resistor	Internal error.	If the error occurs multiple times, replace the control system.
48		Error when testing the wicket door input	Internal error.	If the error occurs multiple times, replace the control system.

Note
 If there are several parallel errors, the first error is displayed. If an error is eliminated, a command (manual transmitter button, a connected operating button or the white circuit board button) may have to be entered in order to display the next error.

12 ERROR MESSAGE FLASHES 4X - PERFORM REFERENCE RUN

- The door is engaged, and the plug connected to the mains.
- The opener light flashes 4x.



ATTENTION!

*During the reference run, force shutdown is inoperable! It is vital for the operator to stay with the opener and attentively monitor the garage area!
 The door movement can be stopped in an emergency immediately by pressing the remote control, the operating button or the white button on the control electronics.*

- ▶ Briefly press remote control button, a connected operating button or the white button on the circuit board → *the opener light comes on permanently.*
- ▶ Briefly press the button again → *Reference run starts in "Close door" direction* → The opener runs up to the CLOSED end position at its minimum speed.
- *Should the travel distance until shutdown in the "Closed" end position be less than 50 mm, the opener travels another 200 mm in the "Open" direction, and then back to the "Closed" end position.*
- ▶ **Check:** Check, by means of several uninterrupted door runs, that the door is fully reaching its closed position and that it is opening all the way.

The opener is now ready again for normal operation.

Note
 Repeat learning run, see „5.1 Teaching in the operator“ on page 8, if even after several uninterrupted door runs the door does not open and close as described in the step “Check”.

13 FORCE SYNCHRONISATION RUN

Perform reference run if, for example, the travel path has moved.

- The door is engaged, and the plug connected to the mains.
- Hold down remote control button Channel 1 for at least 7 sec., until the opener light issues the pulse code flash 4x and the display shows 23 flashing.



ATTENTION!

*During the reference run, force shutdown is inoperable! It is vital for the operator to stay with the opener and attentively monitor the garage area!
 The door movement can be stopped in an emergency immediately by pressing the remote control, the operating button or the white button on the control electronics.*

- ▶ Briefly press remote control button, a connected operating button or the white button on the circuit board → *the opener light comes on permanently.*
- ▶ Briefly press the button again → *Reference run starts in "Close door" direction* → The opener runs up to the CLOSED end position at its minimum speed.
- *Should the travel distance until shutdown in the "Closed" end position be less than 50 mm, the opener travels another 200 mm in the "Open" direction, and then back to the "Closed" end position.*
- ▶ **Check:** Check, by means of several uninterrupted door runs, that the door is fully reaching its closed position and that it is opening all the way.

The opener is now ready again for normal operation.

Note
 If the door starts to move after the remote control button is pressed, you should still continue to hold the button until (approx. 7 sec.) the opener light signals with 4x flashes and the display shows 23 flashing.
 Repeat learning run, see „5.1 Teaching in the operator“ on page 8, if even after several uninterrupted door runs the door does not open and close as described in the step “Check”.

14 OPERATION

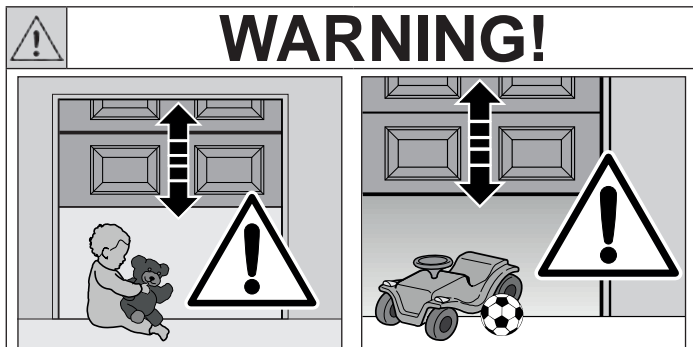

Danger of injury during door travel!

If people or objects are in the area around the door while the door is in motion, this can lead to injuries or damage.

- ▶ Children are not allowed to play near the door system.
- ▶ Make sure that no persons or objects are in the door's area of travel.
- ▶ If the door system has only one safety feature, only operate the garage door operator if you are within sight of the door's area of travel.
- ▶ Monitor the door travel until the door has reached the end-of-travel position.
- ▶ Only drive or pass through remote control door systems if the door is in the Open end-of-travel position!
- ▶ Never stay standing under the open door.



Danger of crushing in the boom

Do not reach into the boom with your fingers during door travel, as this can cause crushing.

- ▶ Do not reach into the boom during door travel



Danger of injury from the cord knob

If you hang on the cord knob, you may fall and injure yourself. The operator could break away and injure persons or damage objects that are located underneath, or the operator itself could be destroyed.

- ▶ Do not hang on the cord knob with your body weight.



Damage due to the cord of the mechanical release

If the cord of the mechanical release becomes caught on a roof carrier system or other parts of the vehicle or door, this can lead to damage.

- ▶ *Make sure that the cable cannot become caught.*

Note

As a general rule, conduct the initial function tests and the initial start-up or extension of the radio system inside the garage.

14.1 Instructing users

- ▶ All persons using the door system must be shown how to operate the garage door operator properly and safely.
- ▶ Demonstrate and test the mechanical release as well as the safety reversal.

14.2 Safety reversal

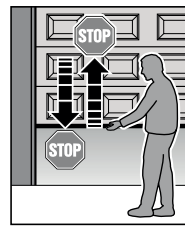

- ▶ To check the safety reversal, stop the door with both hands while it is closing. The door system must stop and initiate the safety reversal.
- ▶ Stop the door with both hands while it is opening. The door system must stop and initiate the safety reversal.
- ▶ Position a test object with a height of approx. 50 mm in the centre of the opening and close the door. The door system must stop and initiate the safety reversal as soon as it reaches the obstacle.

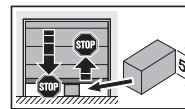

- ▶ In the event of a failure of the safety reversal, a specialist must be commissioned immediately for the inspection and repair work.

14.3 Functions of various radio codes

14.3.1 Channel 1 / Impulse function

During normal operation, the garage door operator works with the impulse sequence control, which is triggered via an external button or a taught-in radio code:

- 1st impulse: → The door runs towards an end-of-travel position.
- 2nd impulse: → The door stops.
- 3rd impulse: → The door runs in the opposite direction.
- 4th impulse: → The door stops.
- 5th impulse: → The door runs in the direction of the end-of-travel position selected in the 1st impulse.

etc.

14.3.2 Channel 2 / Partial opening function (menu 7 = f)

- If the door is **not in partial opening position**, it is moved in the partial opening position using the partial opening radio code.
- If the door is **in partial opening position**, it is moved in the CLOSE end-of-travel position using the partial opening radio code and in the OPEN end-of-travel position using the impulse radio code.

14.3.3 Channel 2 / light (menu 7 = e)

- The drive or external lighting can be activated via channel 3 independent of the settings in menus **b** und **c**, see on **page 16**.

14.4 Behaviour during a power failure / Behaviour after the power returns

- ▶ To be able to open or close the garage door by hand during a power failure, it must be disengaged from the slide carriage while the door is closed, see **4.5.1 Manual operation on page 6**.
- ▶ After the power returns, the slide carriage for automatic operation must be re-engaged, see **4.5.2 Automated operation on page 6**.

15 INSPECTION AND MAINTENANCE

- ▶ The garage door operator is maintenance-free.
- ▶ In the interest of your own safety, we recommend having the door system inspected and maintained by a qualified person in accordance with the manufacturer's specifications.

	<h1>WARNING!</h1>
Danger of injury due to unexpected door travel!	
Unexpected door travel may occur during inspection and maintenance work if the door system is inadvertently actuated by other persons.	
<ul style="list-style-type: none"> ▶ Disconnect the mains plug whenever performing work on the door system. ▶ Safeguard the door system against being switched on again without authorisation. 	

Inspection and repairs may only be carried out by a qualified person. Contact your supplier for this purpose.

A visual inspection may be carried out by the operator.

- ▶ Check all safety and protective functions **monthly**.
- ▶ Check safety devices without self-testing every **six months**.
- ▶ Any malfunctions and / or defects must be remedied **immediately**.

16 DISMANTLING AND DISPOSAL

- ▶ When dismantling the door, observe the applicable regulations governing work safety.
- ▶ Have a specialist dismantle the garage door operator in the reverse order of these instructions and dispose of it properly.



Electrical and electronic devices, as well as batteries, may not be disposed of in household rubbish, but must be returned to the appropriate recycling facilities.

17 WARRANTY CONDITIONS

17.1 Warranty

We shall be exempt from our warranty obligations and product liability in the event that the customer carries out his own structural alterations or undertakes improper installation work or arranges for same to be carried out by others without our prior approval and contrary to the fitting guidelines we have provided. Moreover, we shall accept no responsibility for the inadvertent or negligent use of the operator and the accessories nor for improper maintenance of the door and its counterbalance. Batteries and light bulbs are also not covered by the warranty.

17.2 Warranty period

In addition to the statutory warranty provided by the dealer in the sales contract, we grant the following warranty for parts from the date of purchase:

- **60 months or 200.000 cycles** for the operator mechanics, motor and motor control
- **24 months** on radio equipment, accessories and special systems

There is no warranty on consumables (e.g. fuses, batteries, lamps). Claims made under the warranty do not extend the warranty period. For replacement parts and repairs the warranty period is six months or at least the remainder of the warranty period.

17.3 Prerequisites

A claim under this warranty is only valid for the country in which the equipment was bought. The product must have been purchased through our authorised distribution channels.

A claim under this warranty exists only for damage to the object of the contract itself. Reimbursement of expenditure for dismantling and fitting, testing of corresponding parts, as well as demands for lost profits and compensation for damages, are excluded from the warranty.

The receipt of purchase substantiates your right to claim under the warranty.

Replaced parts become our property

17.4 Performance

For the duration of the warranty we shall eliminate any product defects that are proven to be attributable to a material or manufacturing fault. We pledge to replace free of charge and at our discretion the defective goods with nondefective goods, to carry out repairs, or to grant a price reduction.

Damages caused by the following are excluded:

- Improper fitting and connection
- Improper initial start-up and operation
- External factors such as fire, water, abnormal environmental conditions
- Mechanical damage caused by accidents, falls, impacts
- Negligent or intentional destruction
- Normal wear or deficient maintenance
- Repairs conducted by unqualified persons
- Use of non-original parts
- Removal or defacing of the data label

18 TECHNICAL DATA

Mains voltage:	230/240V, 50 Hz, Standby < 0,5 W	
Protection category	Opener: IP20, only for dry rooms Control board housing: IP65	
Temperature range	-20 °C to +60 °C	
Automatic safety cut-out	Is automatically taught in for both directions separately.	
End-of-travel position cut-out force limit	Self-learning, wear-free, as it has no mechanical switches. Additionally integrated run time limitation to approx. 140 s. Automatic safety cut-out, readjusting at every door run.	
Rated load	GA403-G:	270 N
	GA403-TG:	270 N
Pull and push force	GA403-G:	1000 N
	GA403-TG:	1000 N
Power	GA403-G:	0,4 kW
	GA403-TG:	0,4 kW
Duty cycle	KB 2 min.	
Motor	Direct current motor with hall sensor	
Connection	Removable connection technology for external equipment with 24 V DC low safety voltage, such as internal and external buttons with impulse operation.	
Special functions	<ul style="list-style-type: none"> ● Stop/off switch ● Photocell (Contact or 2-wire) ● closing edge safety device (8k2 or OSE) ● Option relay; optional for warning lights, additional external lighting, door CLOSED or door OPEN display. ● External LED-Light 24 VDC / max. 10W 	
Emergency release	Actuated from inside with pull cord in the event of a power failure	
Universal fittings	For up-and-over doors and Sectional doors	
Door travel speed*	<ul style="list-style-type: none"> ● In CLOSE direction max. 14 cm/s ● In OPEN direction max. 22 cm/s 	
* Dependent on door size and weight		
Airborne sound emission of the garage door operator	≤ 70 dB (A)	
Operator boom	Extremely flat (no more than 30 mm high) with integral door security kit. Boom in toothed belt or synthetic belt version.	

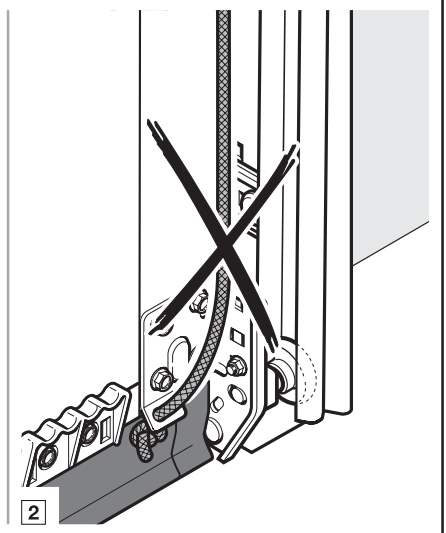
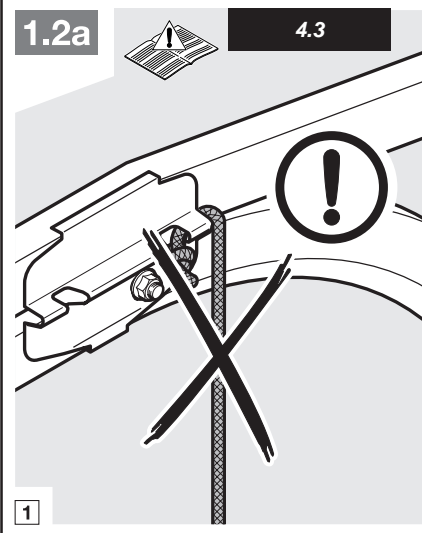
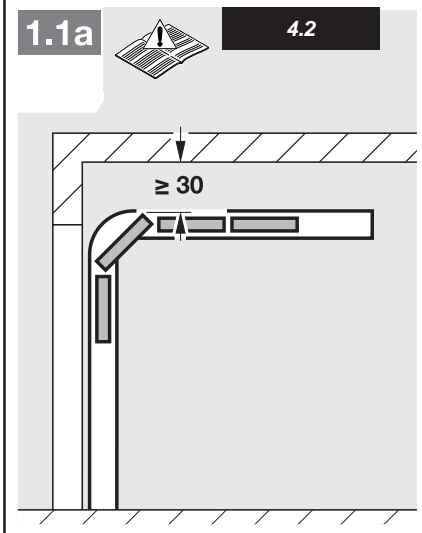
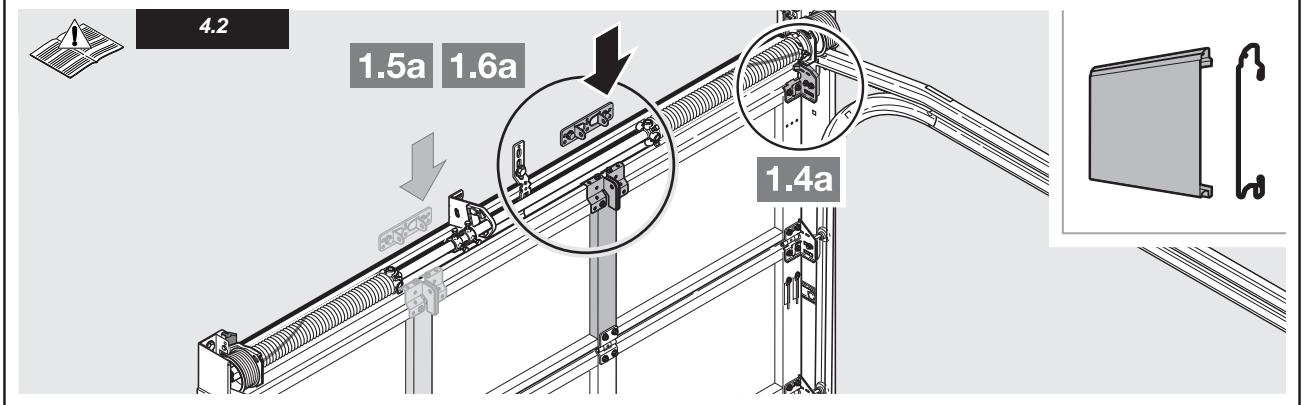
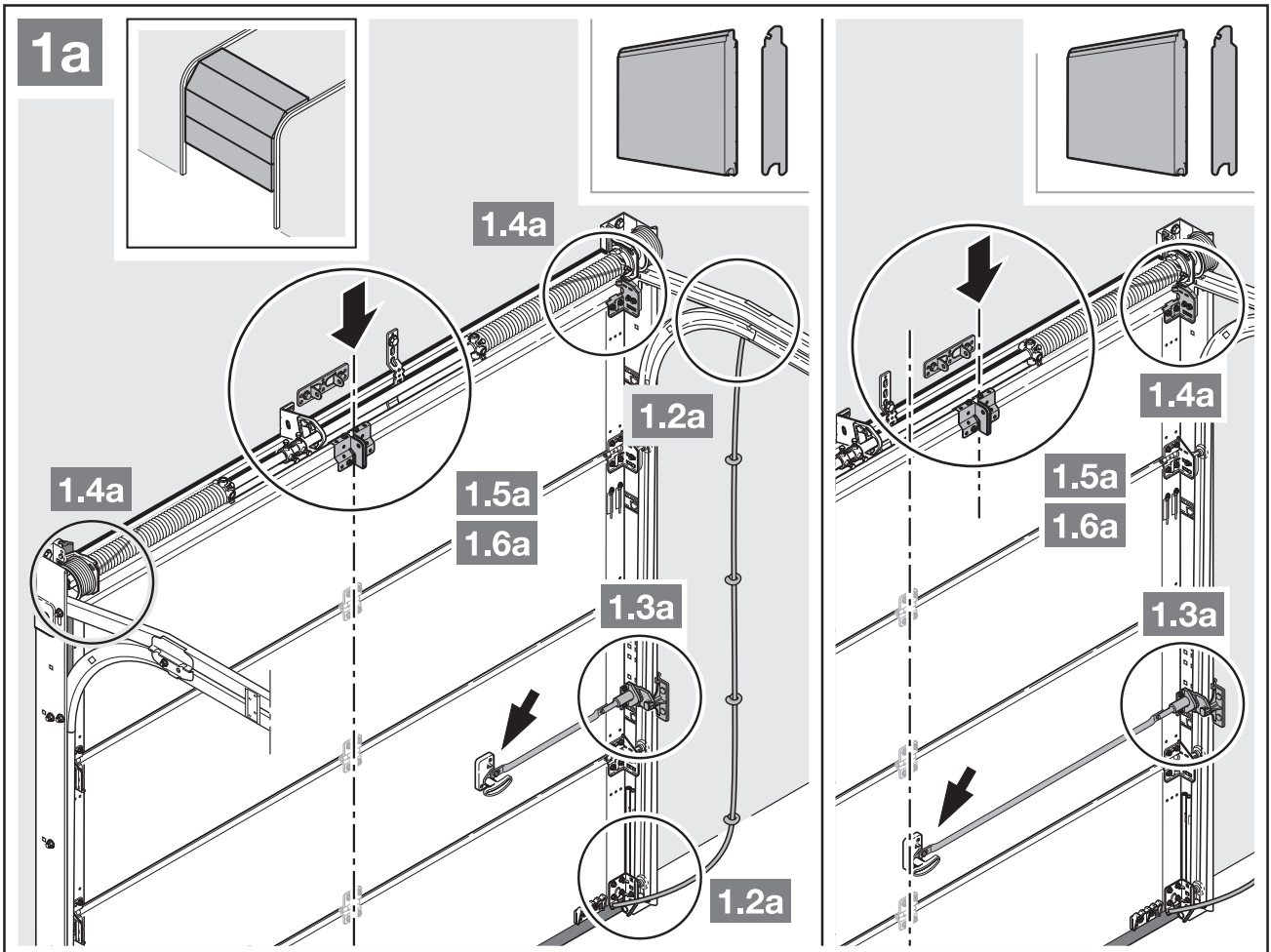



1.3a



4.3

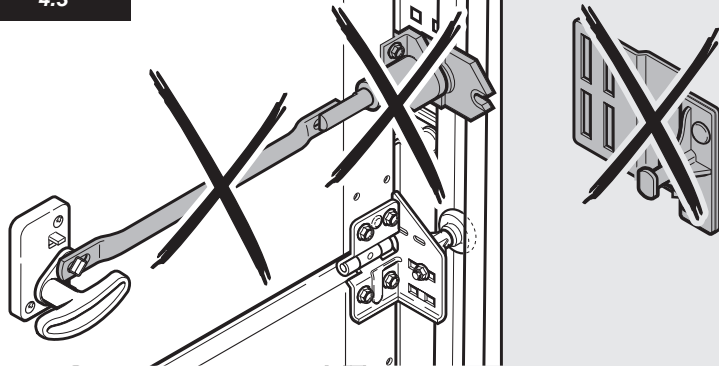

1.4a

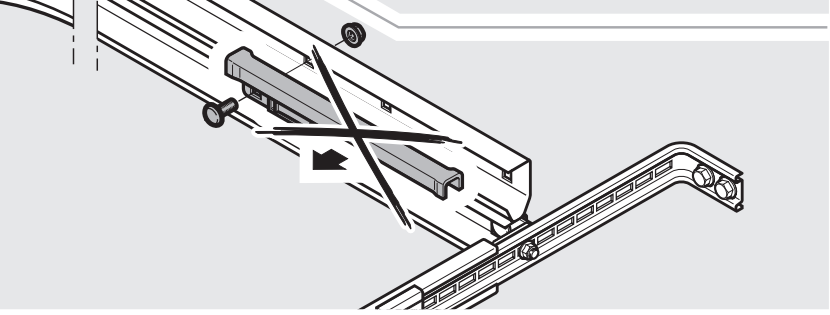
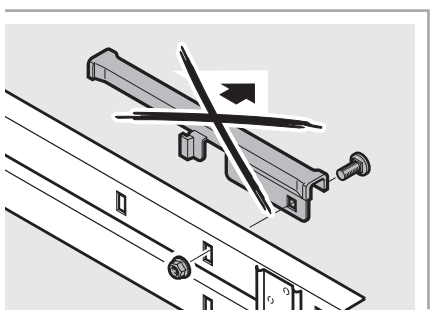
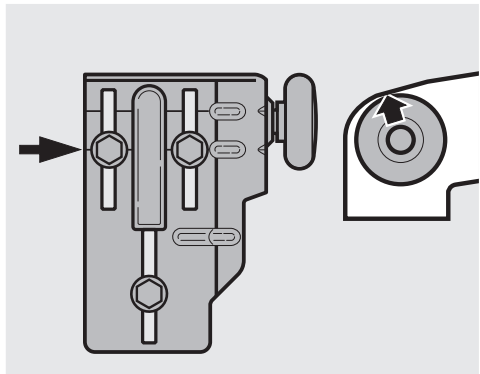
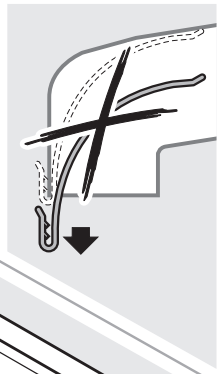
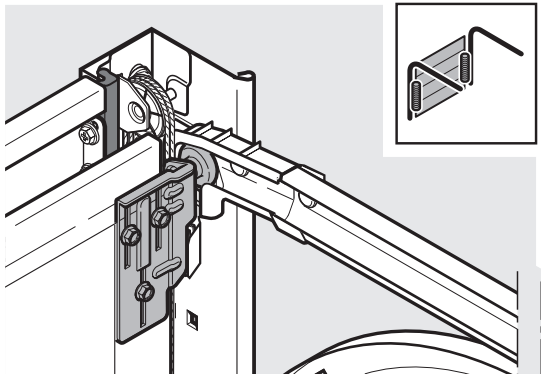
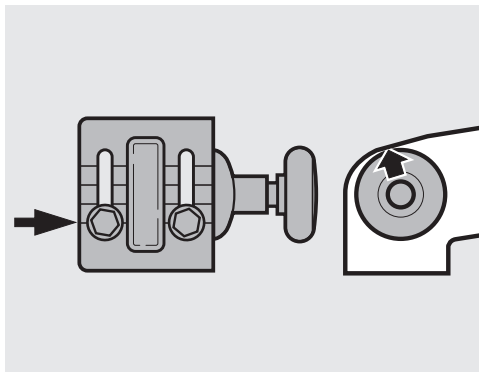
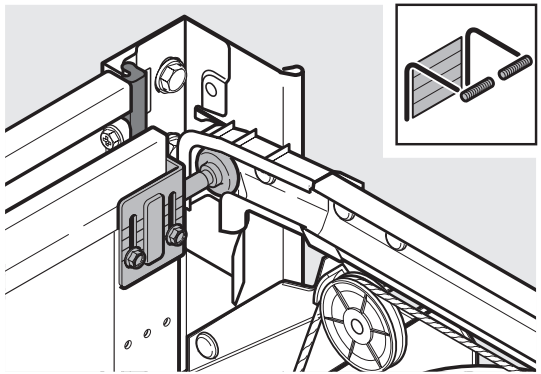
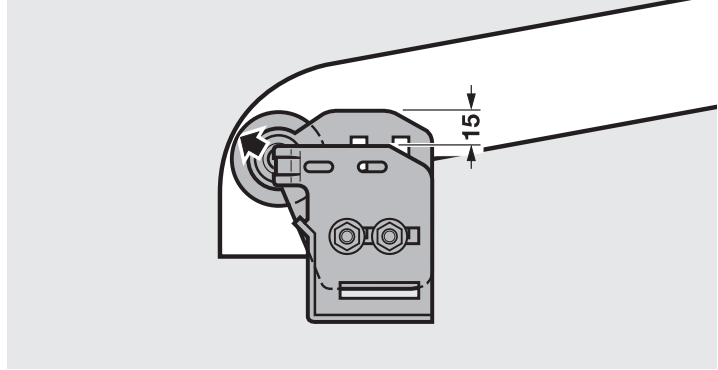
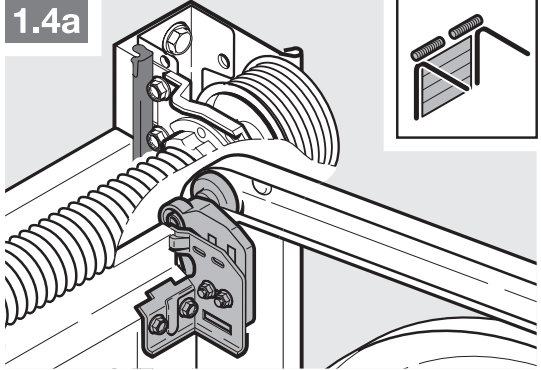



1.5a



4.3

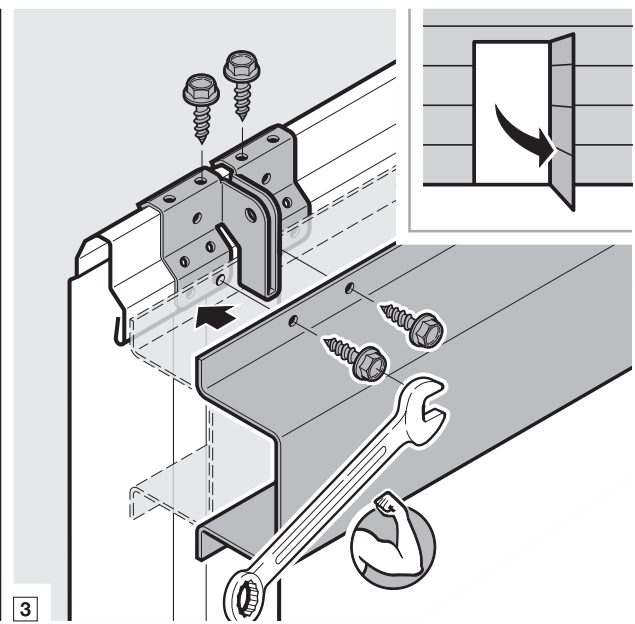
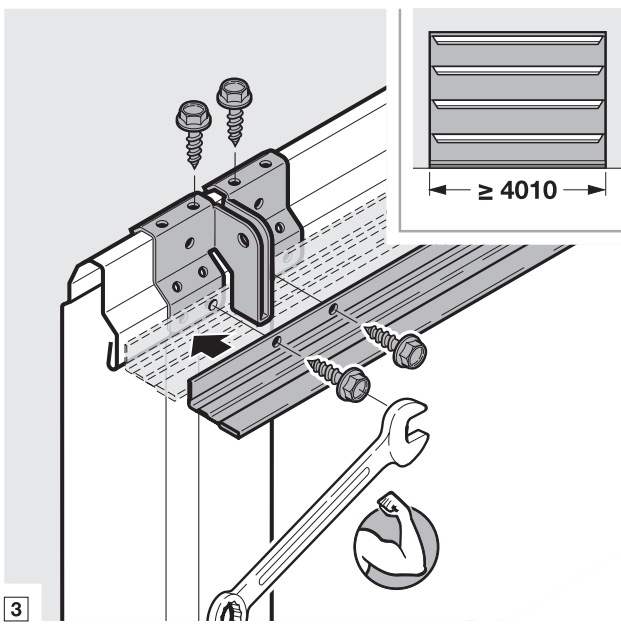
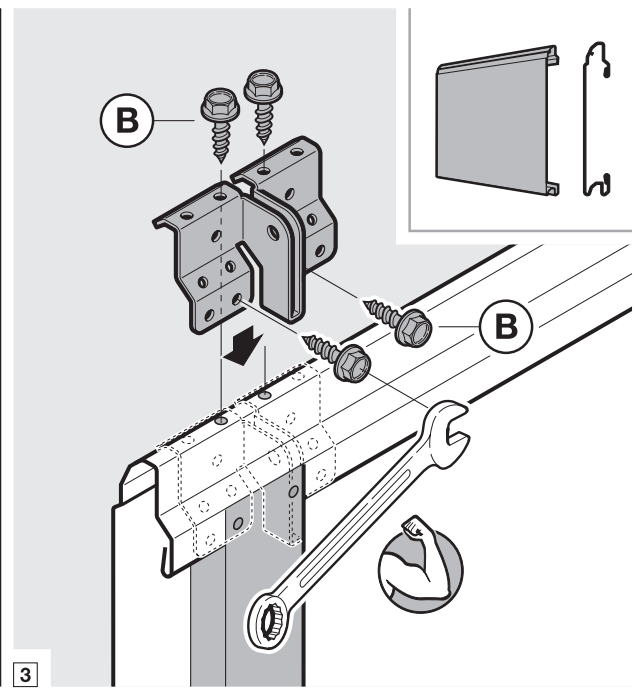
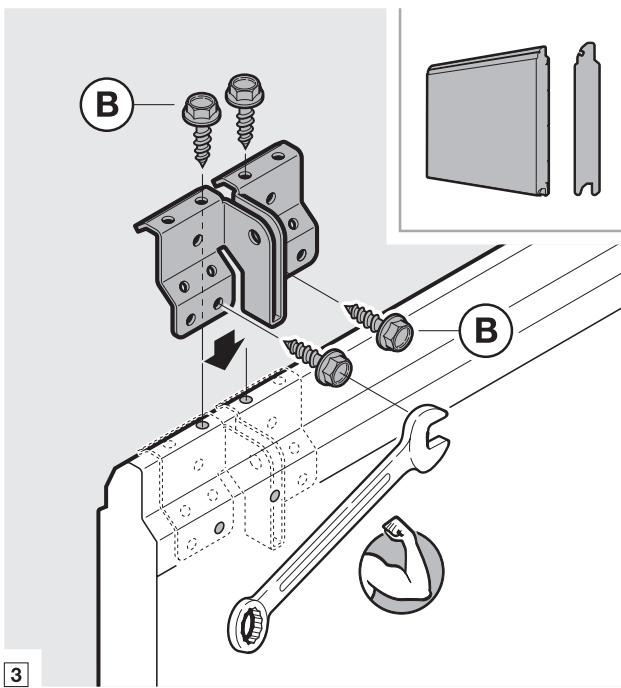
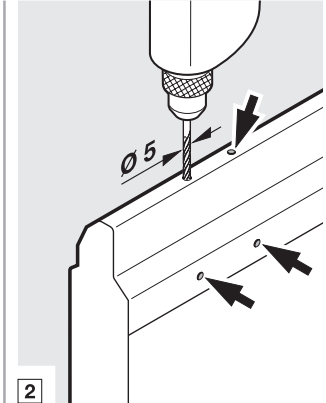
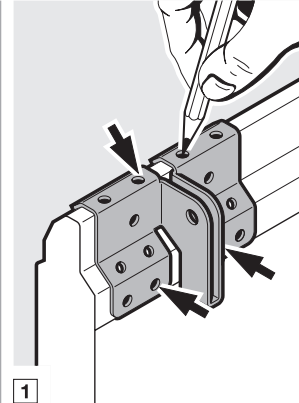
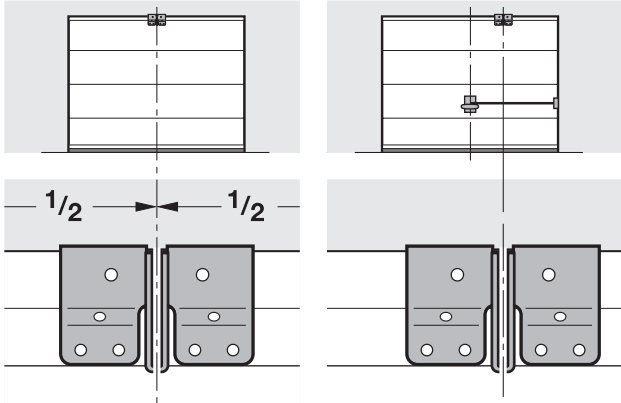
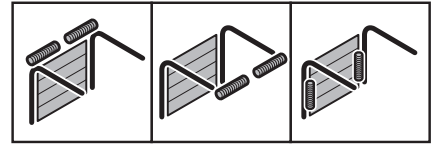

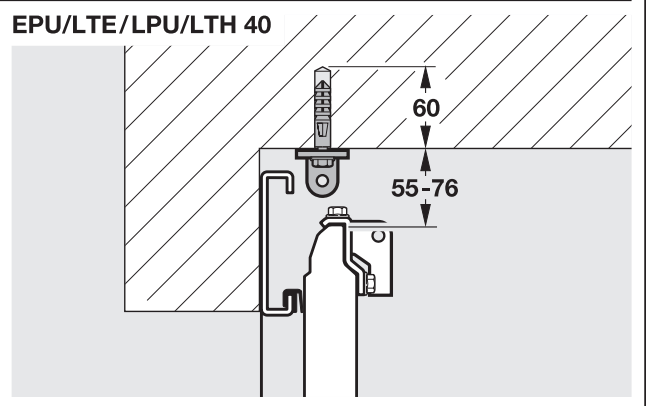
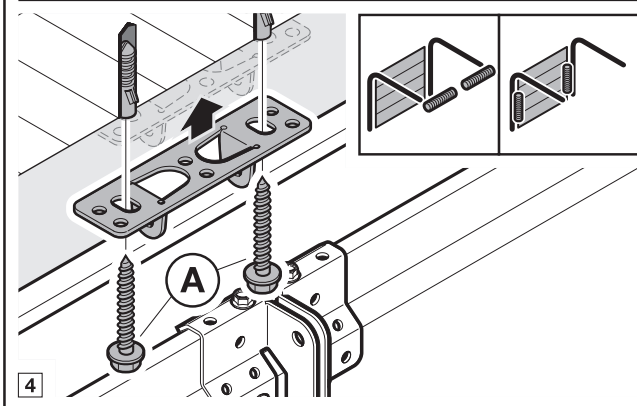
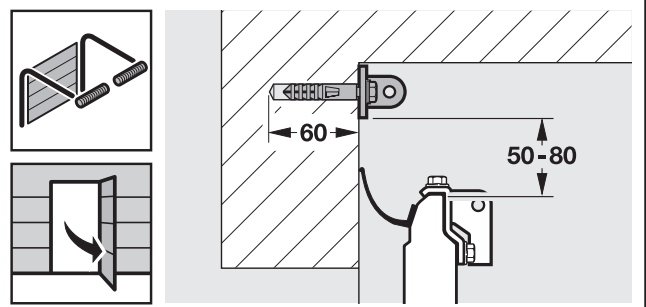
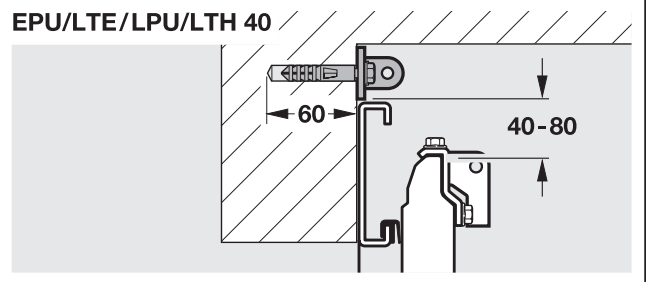
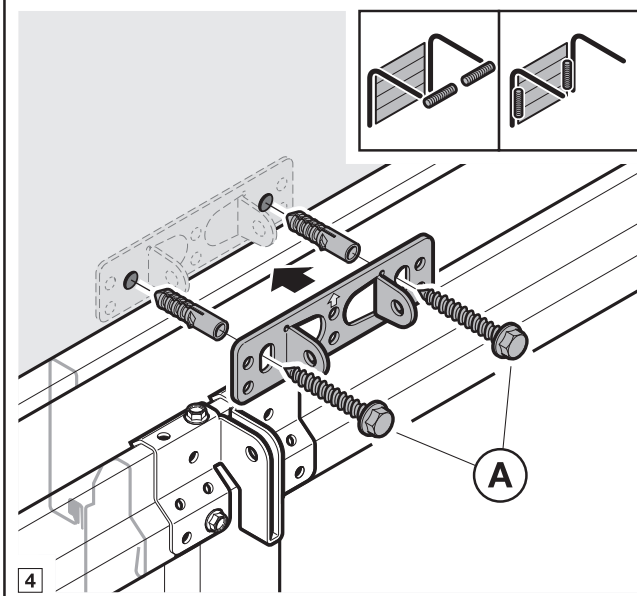
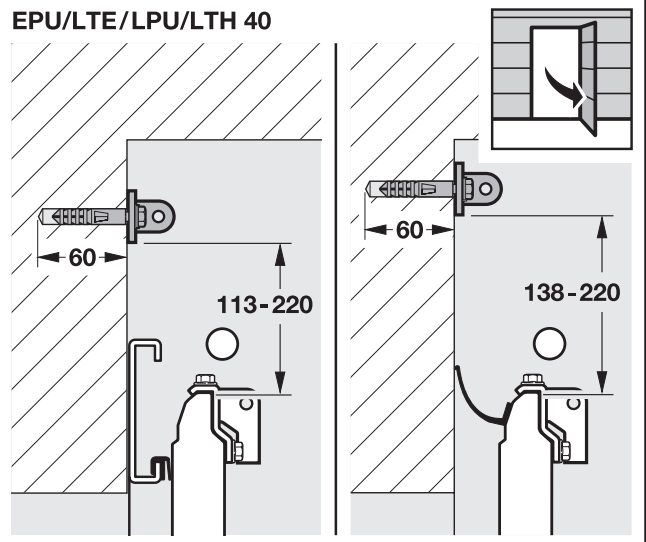
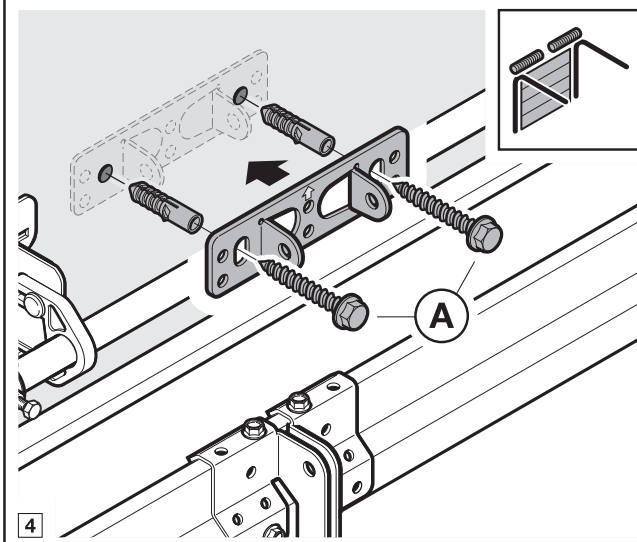
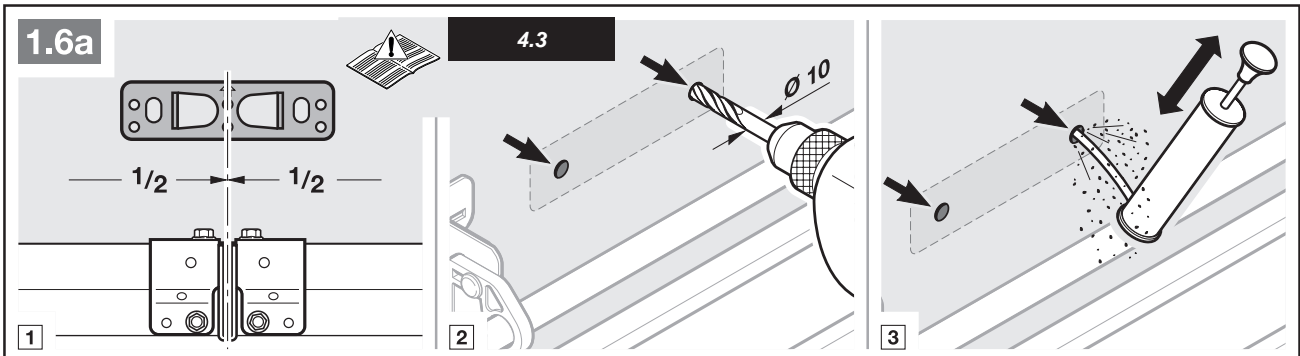

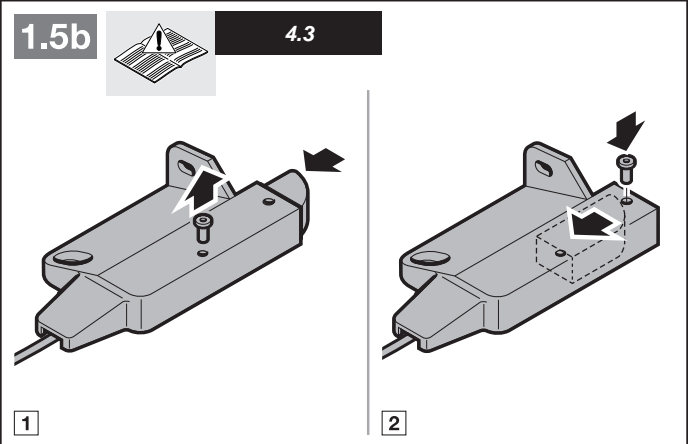
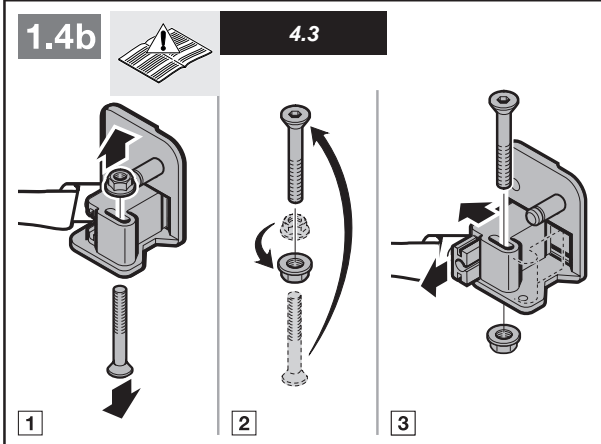
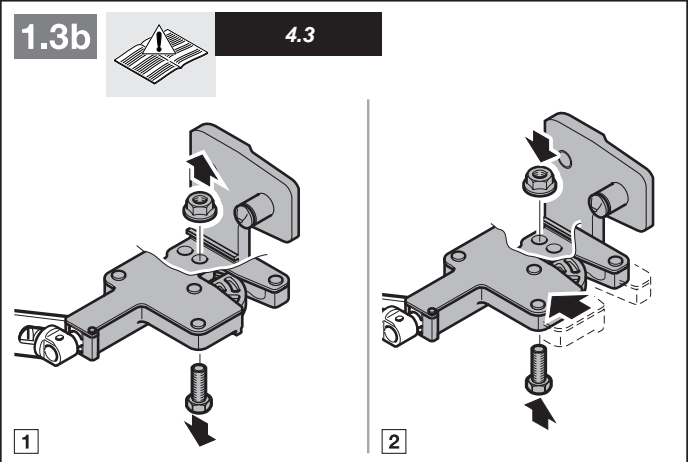
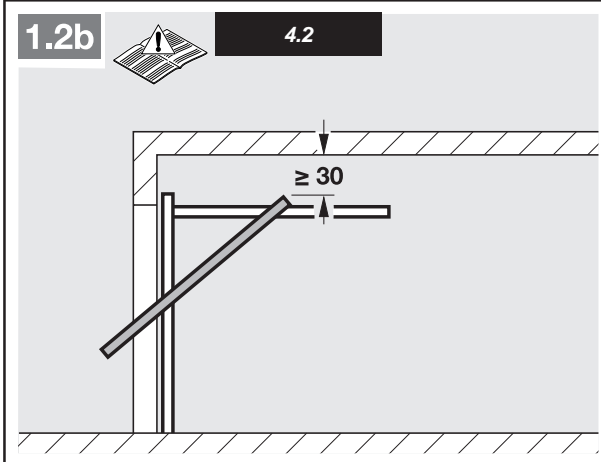
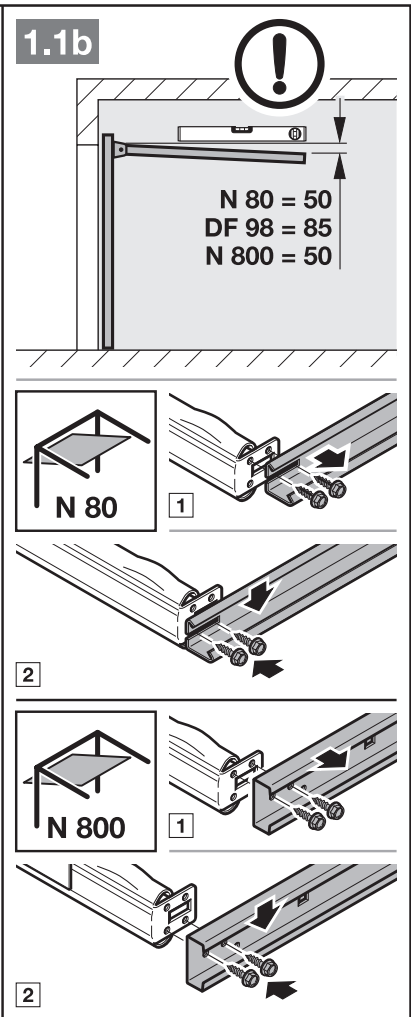
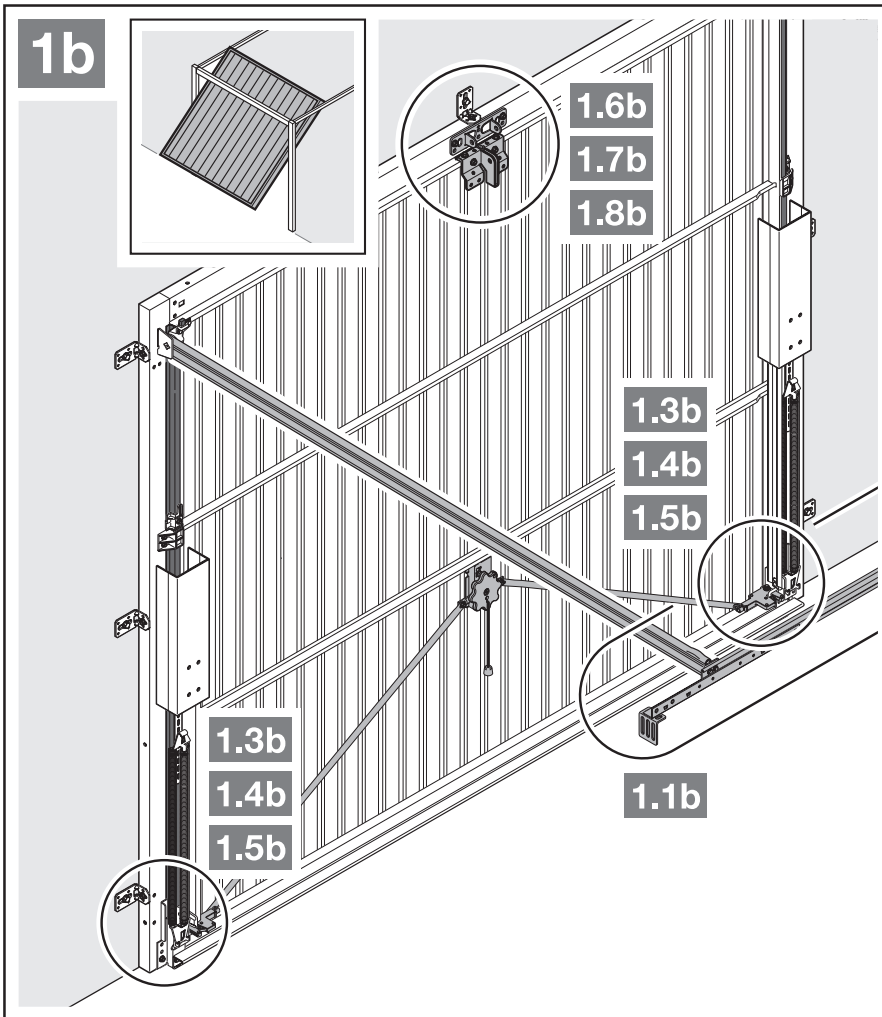

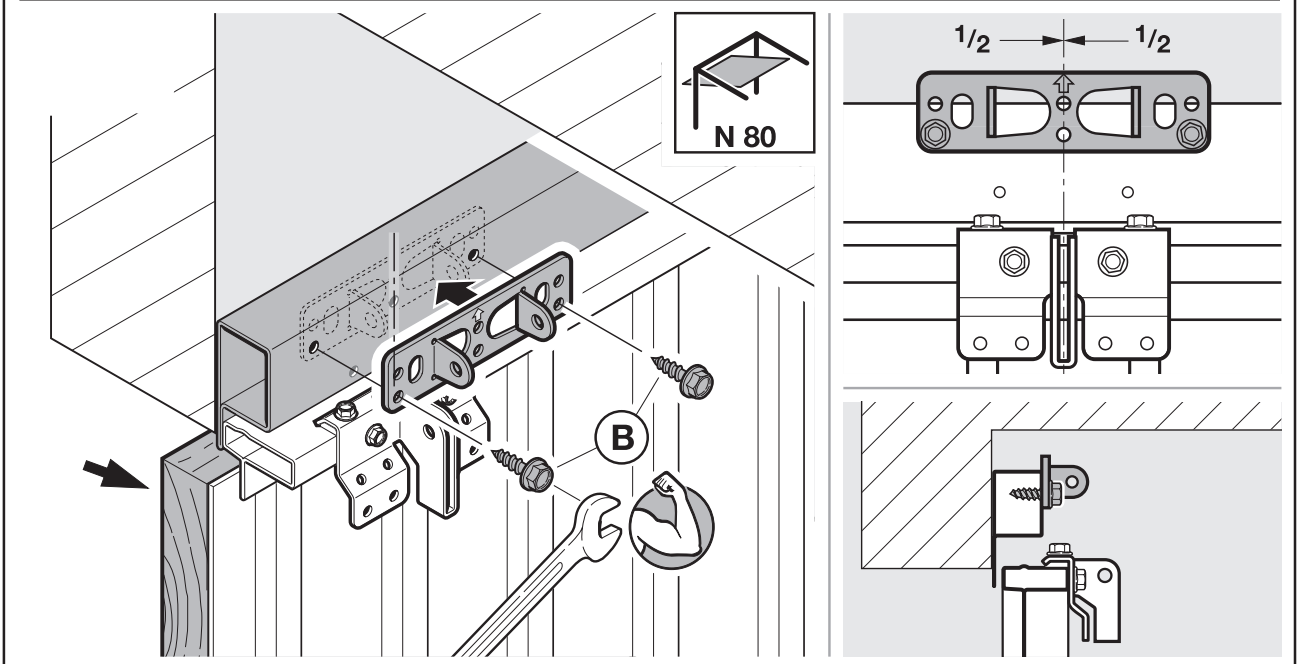
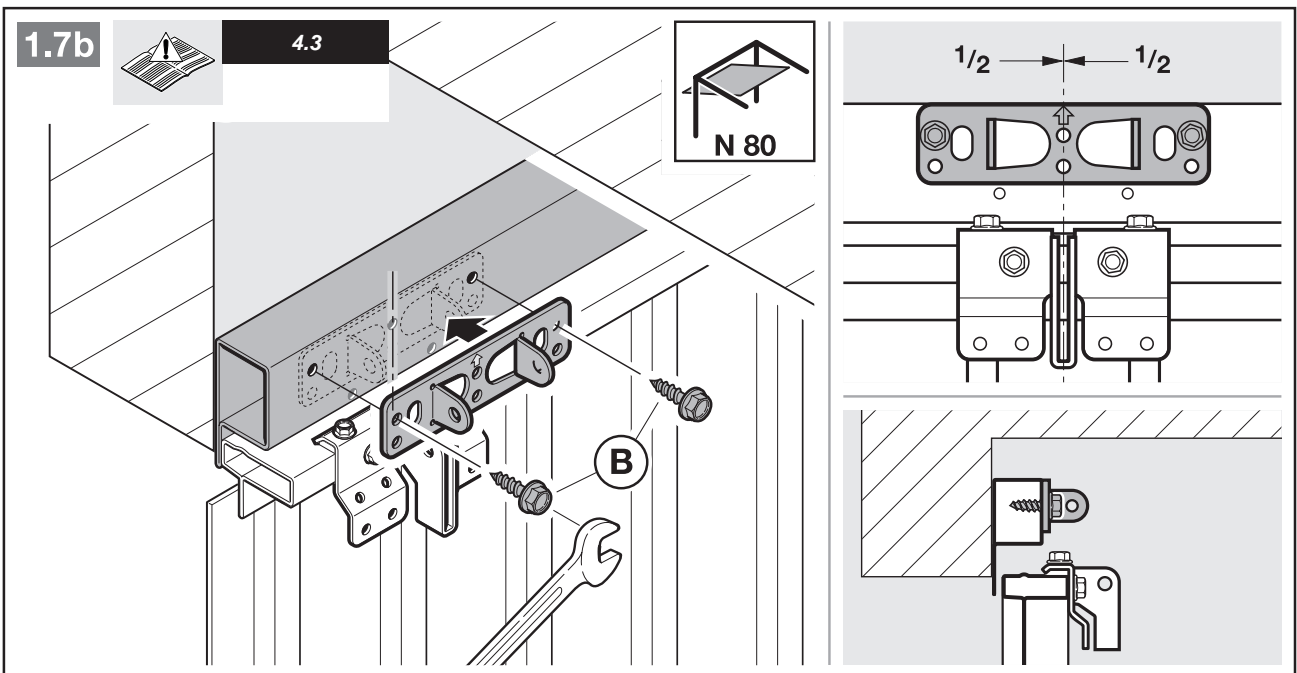
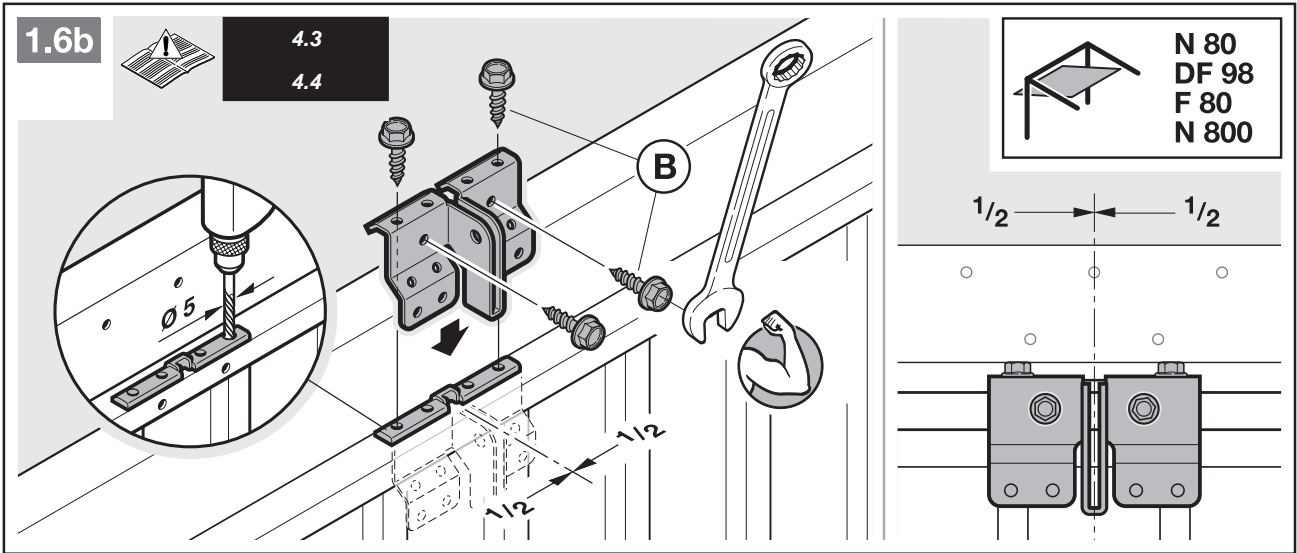



1.8b



4.4

1

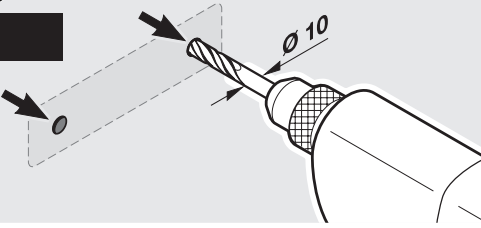

2

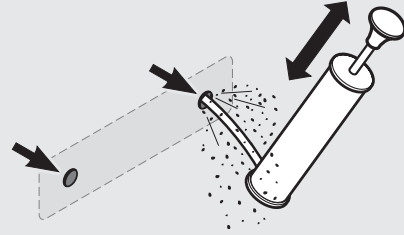

3

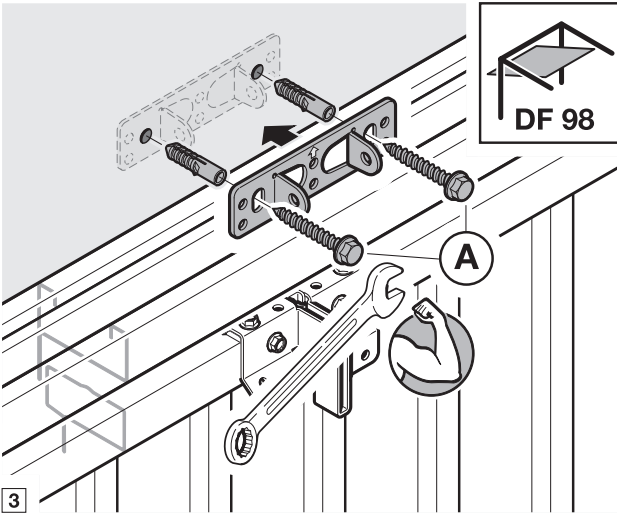

DF 98

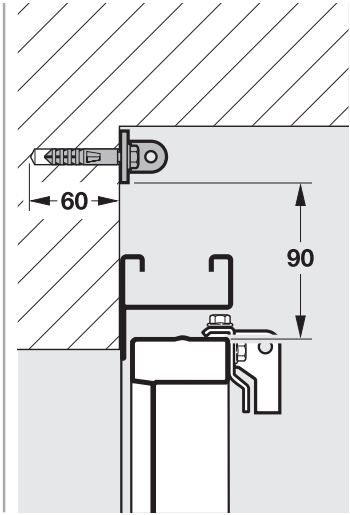
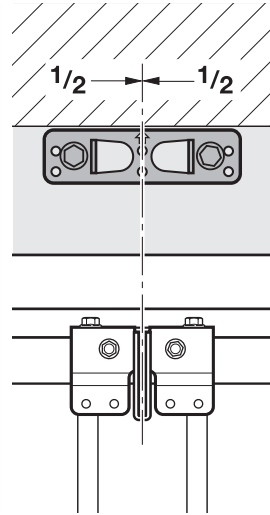

3

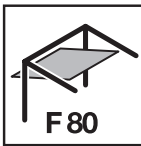
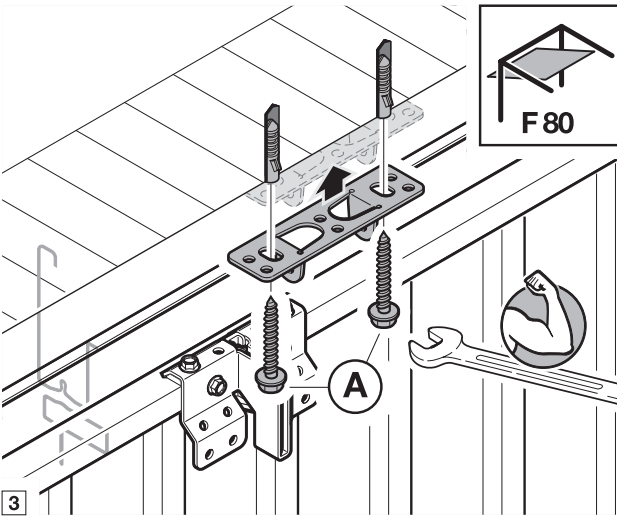

F 80

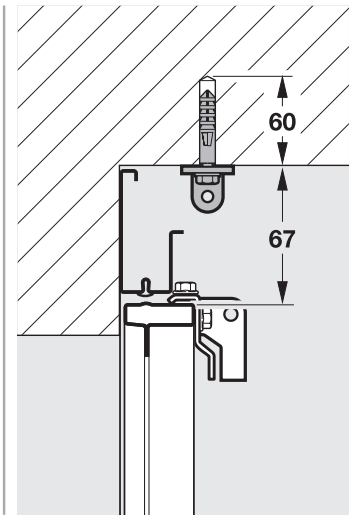
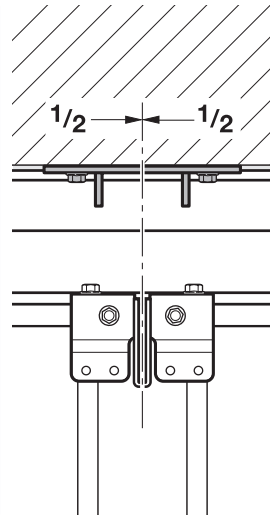

3

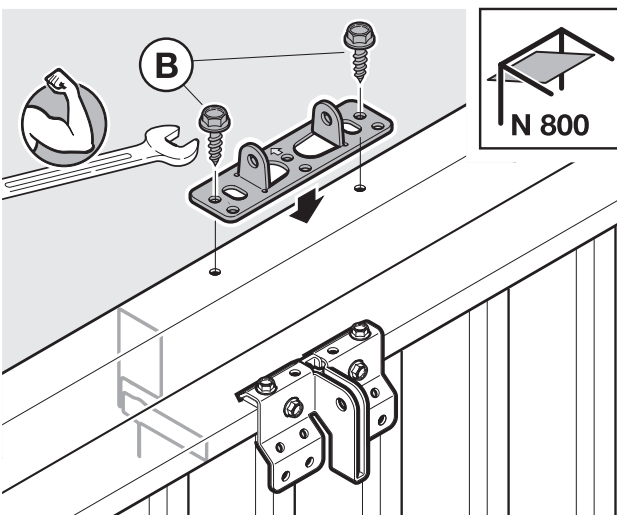

N 800

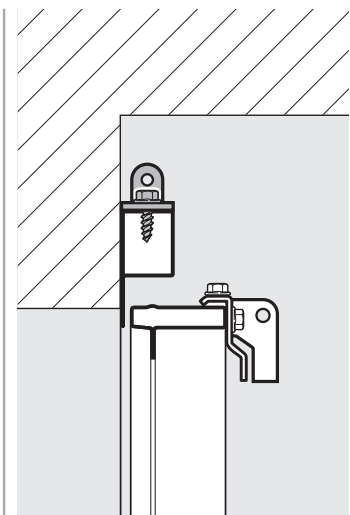
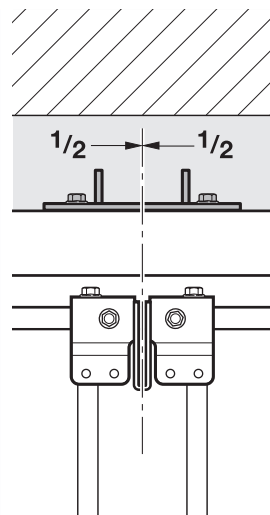

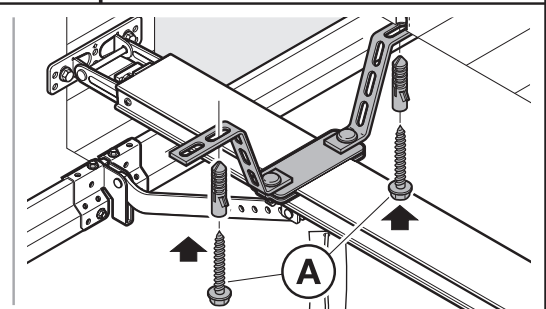
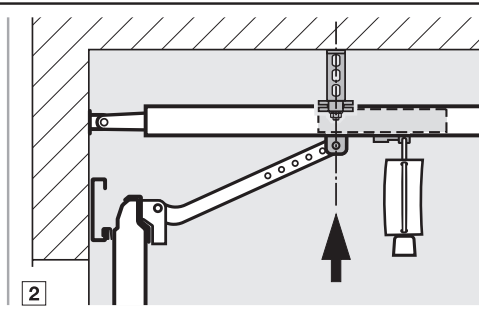
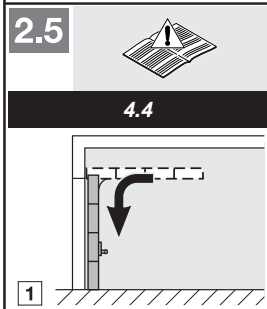
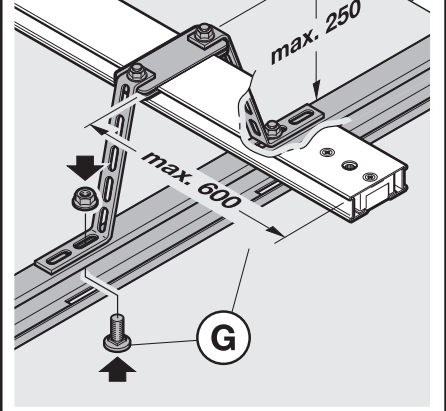
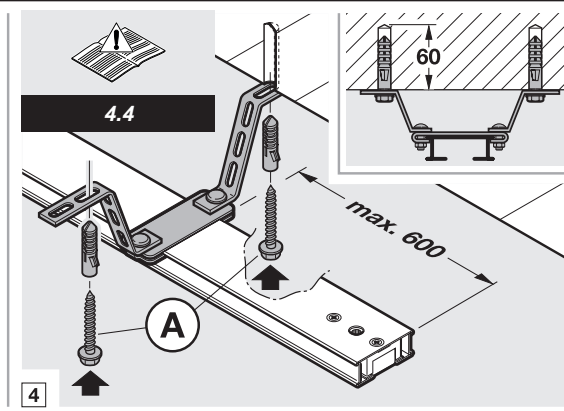
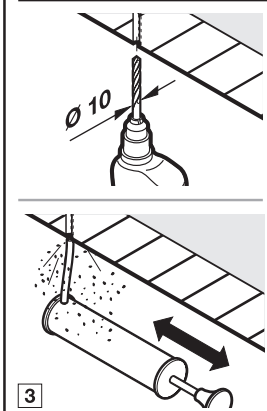
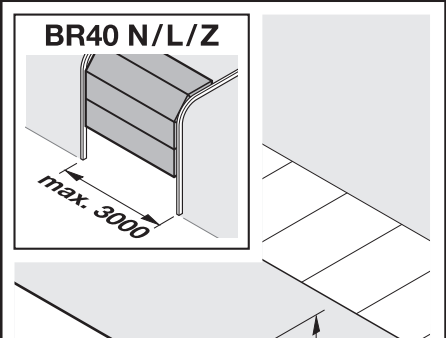
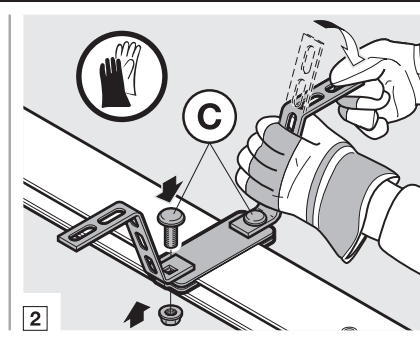
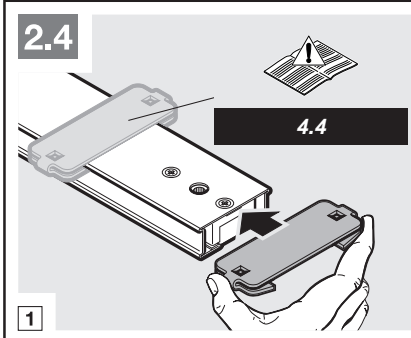
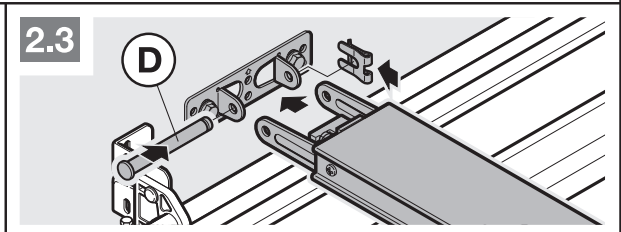
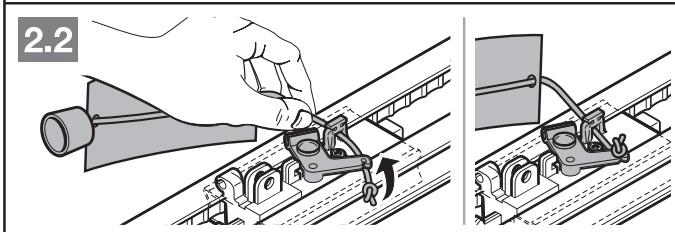
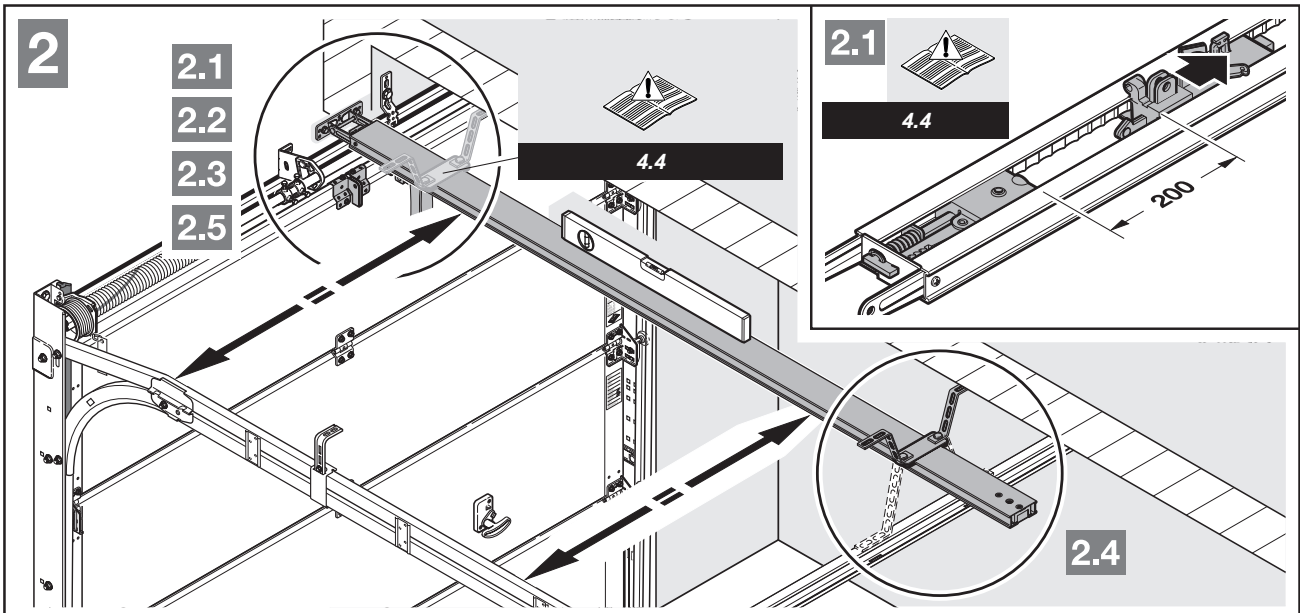



3a

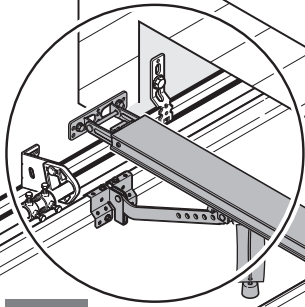
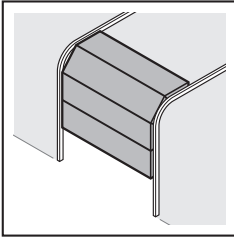

3.1a

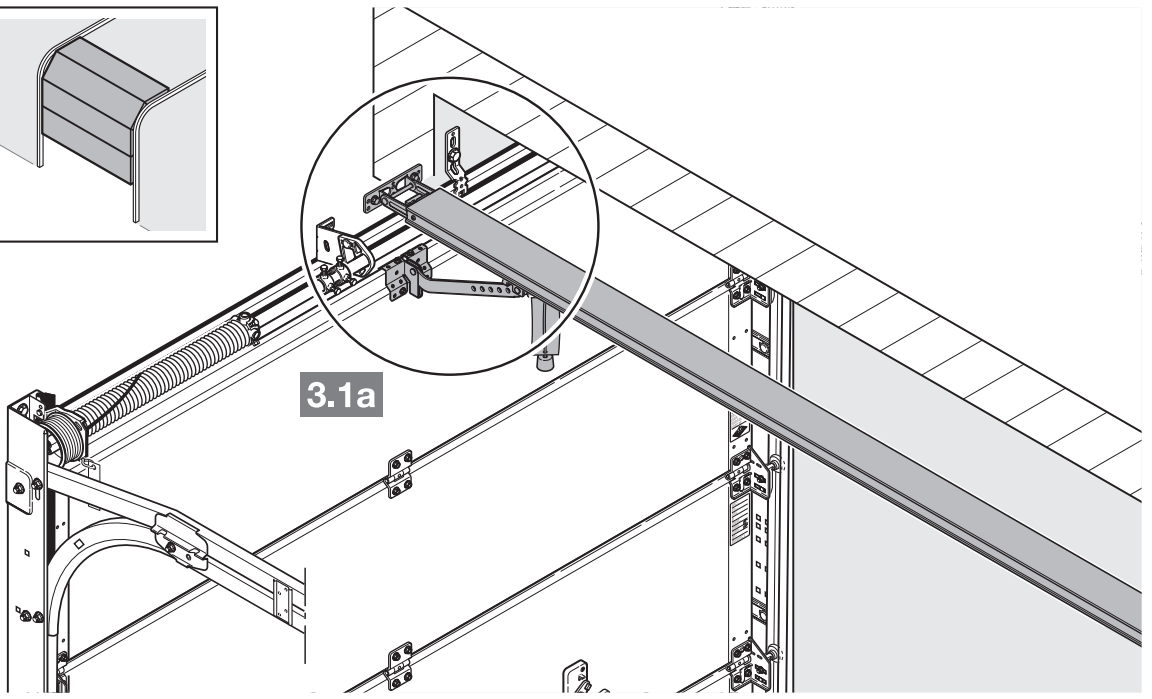

3.1a

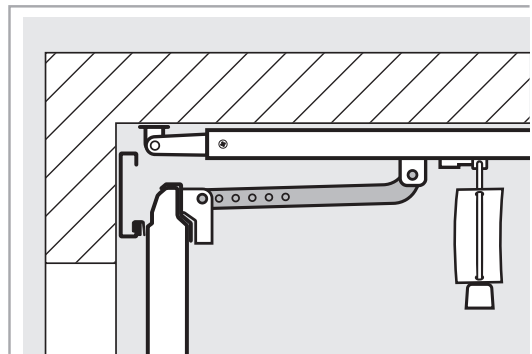
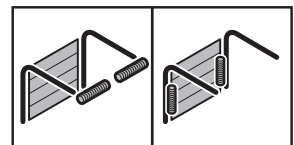
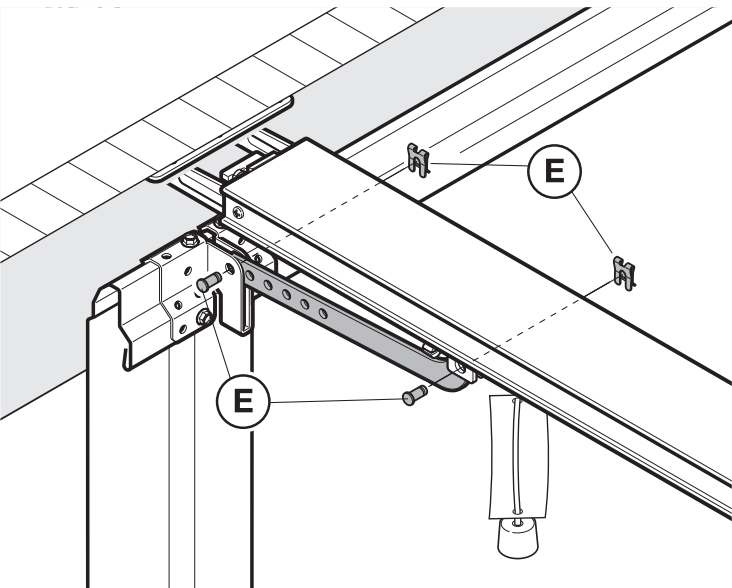
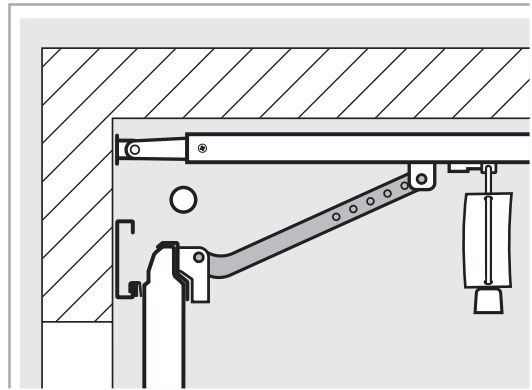
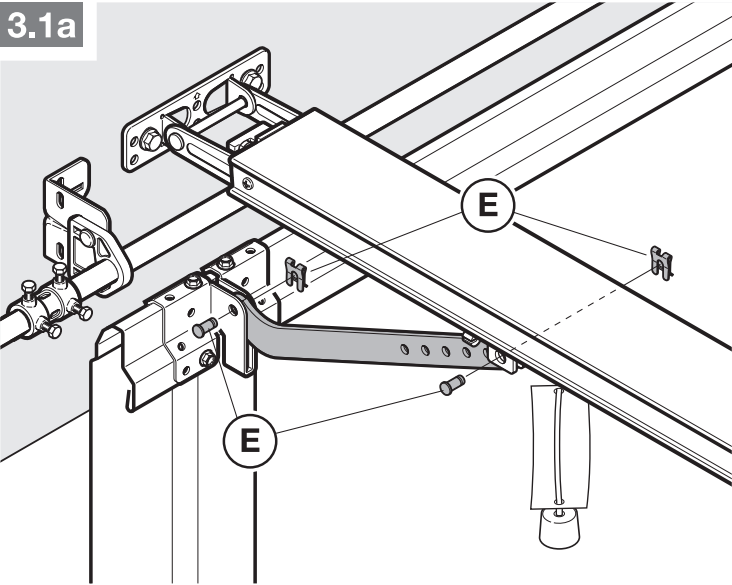



3b

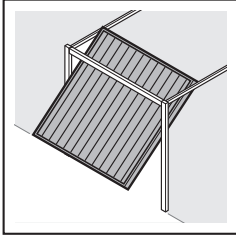

3.1b

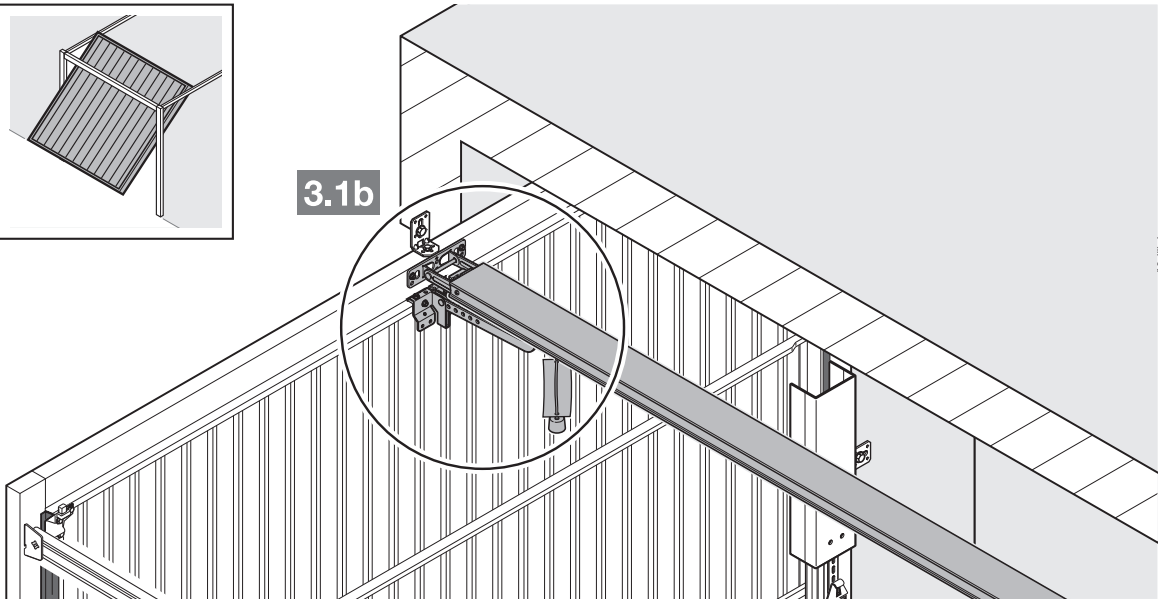

3.1b

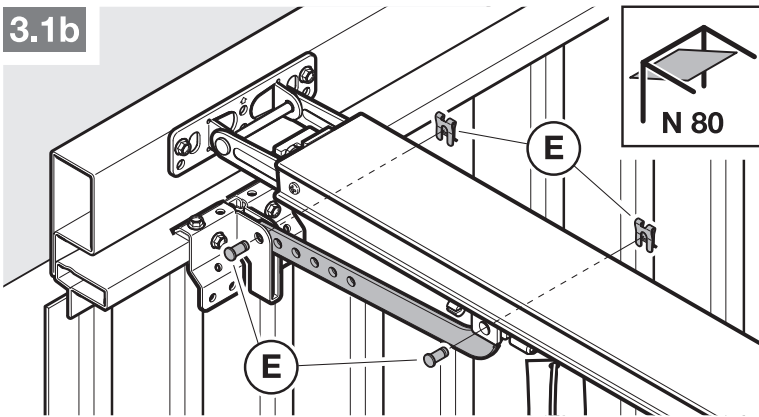

N 80

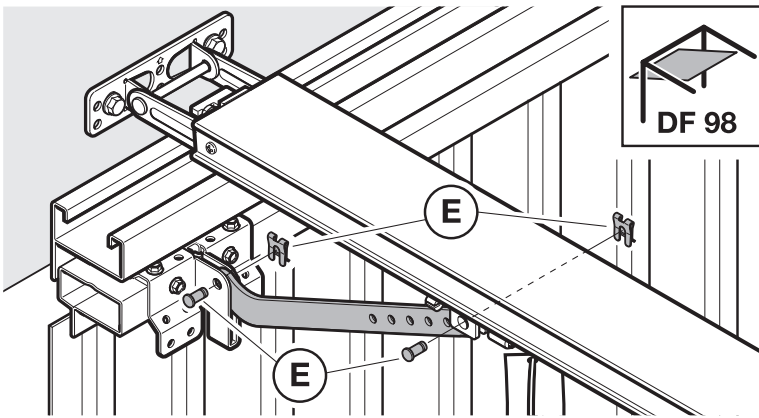
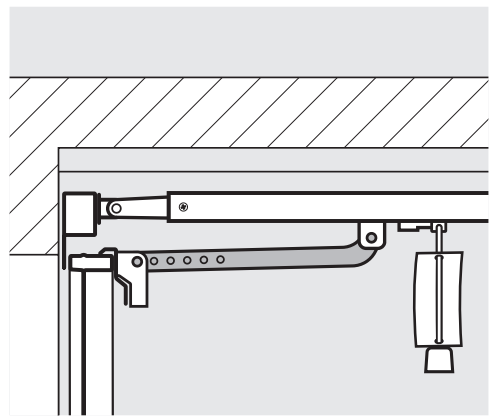

DF 98

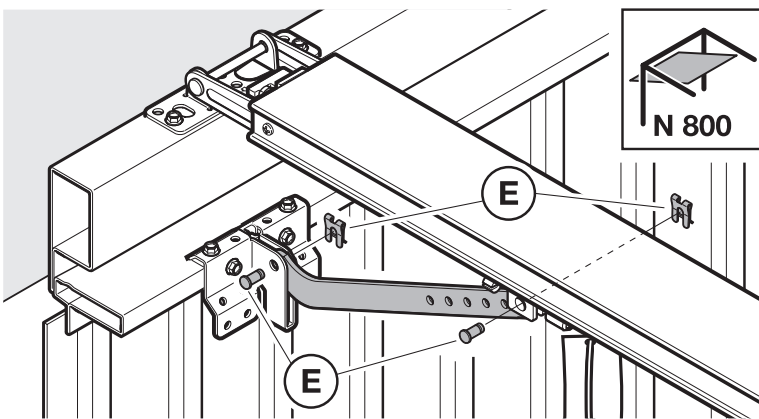
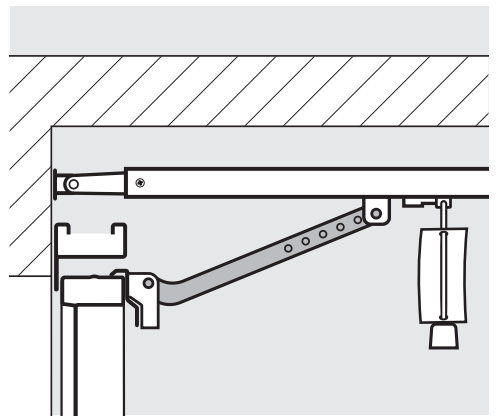

N 800

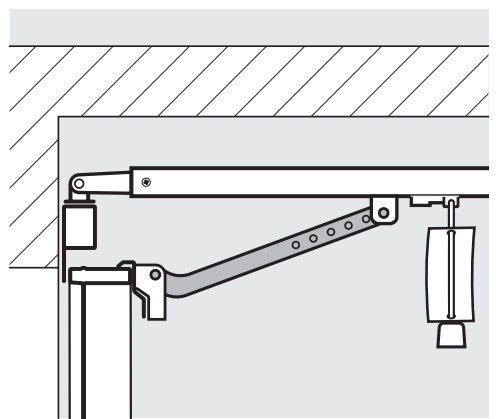

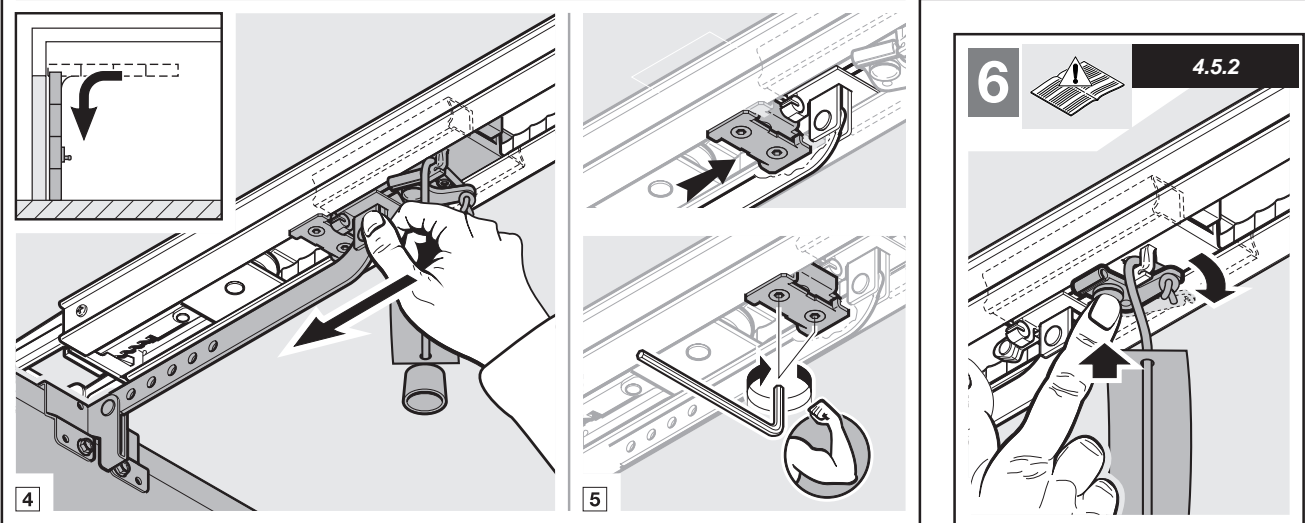
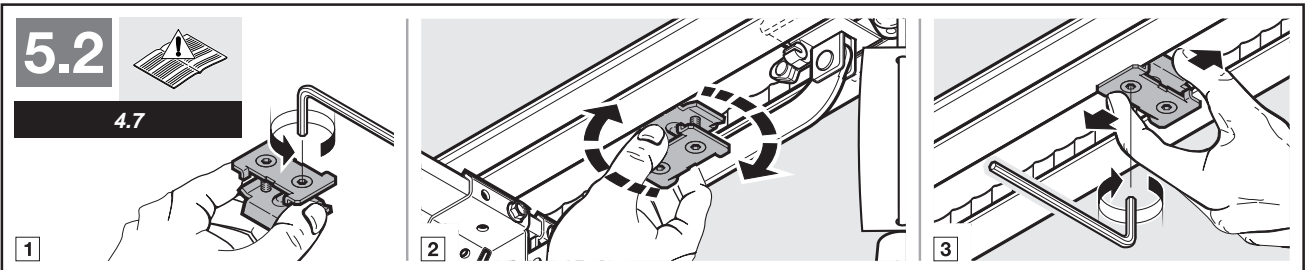
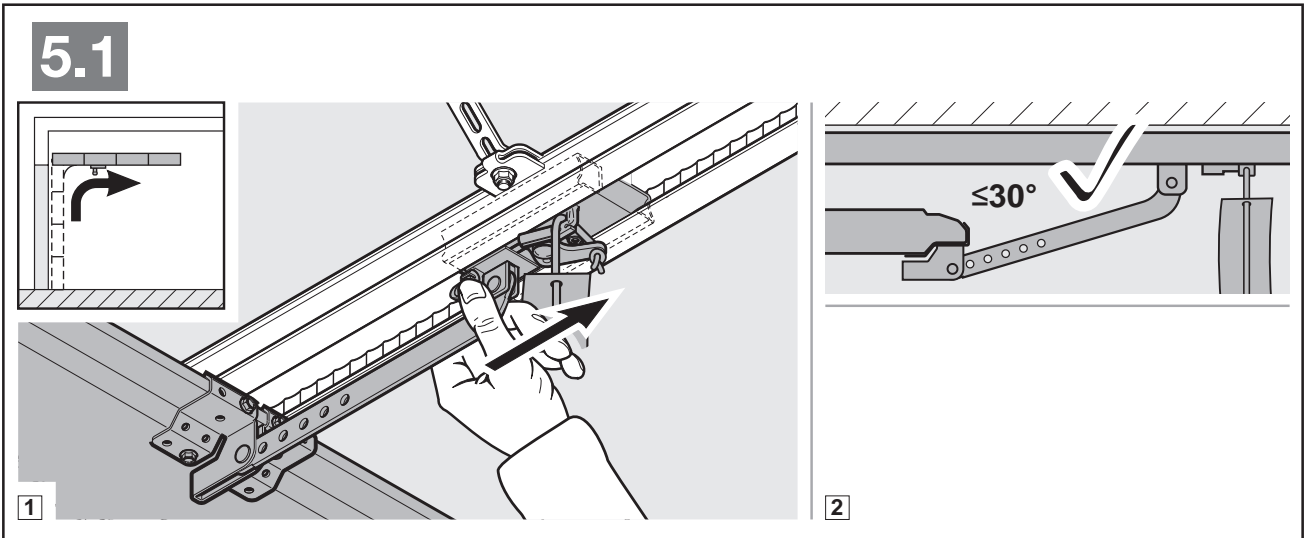
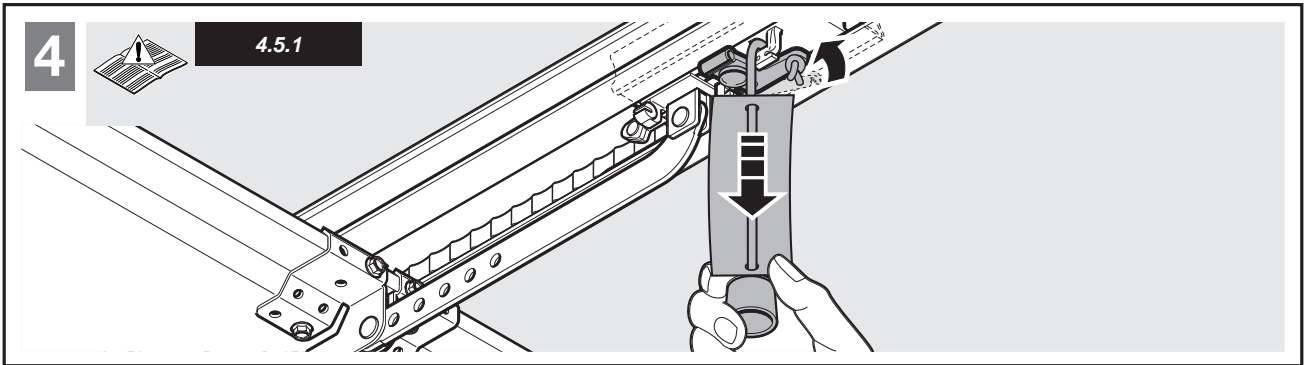

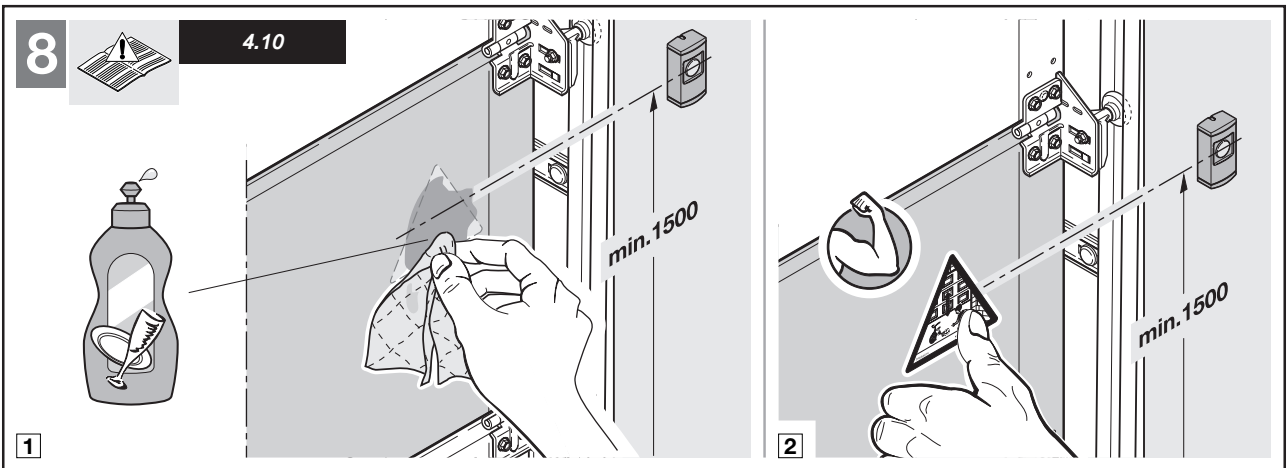
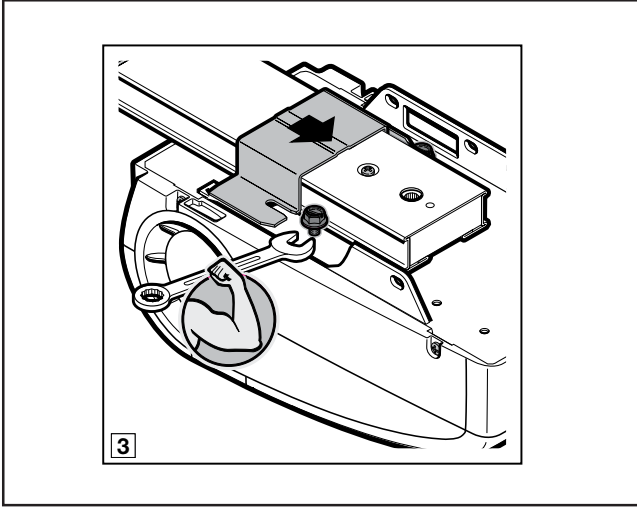
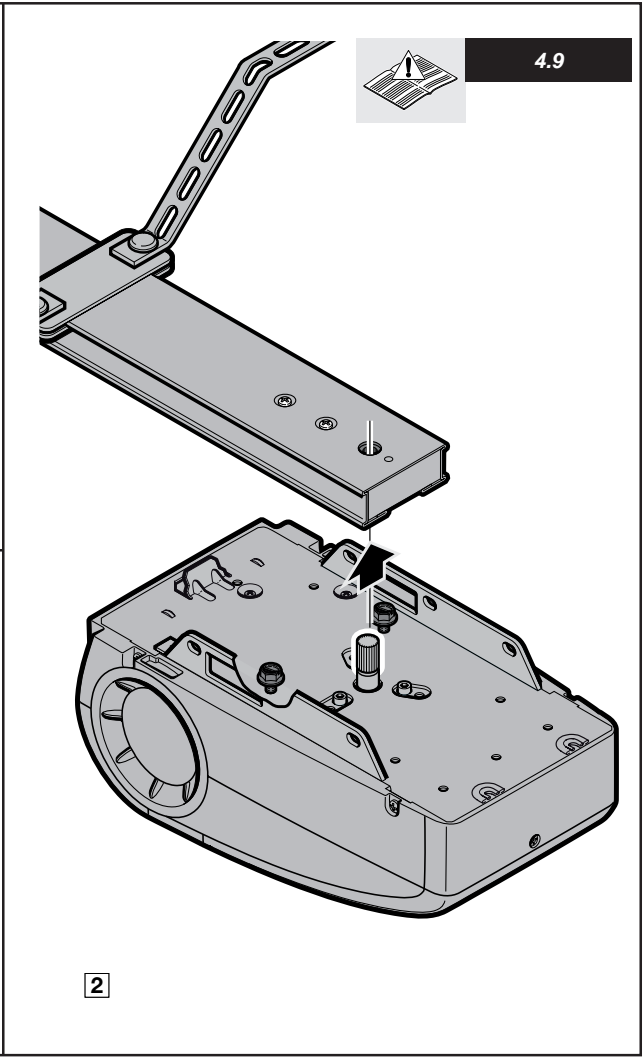
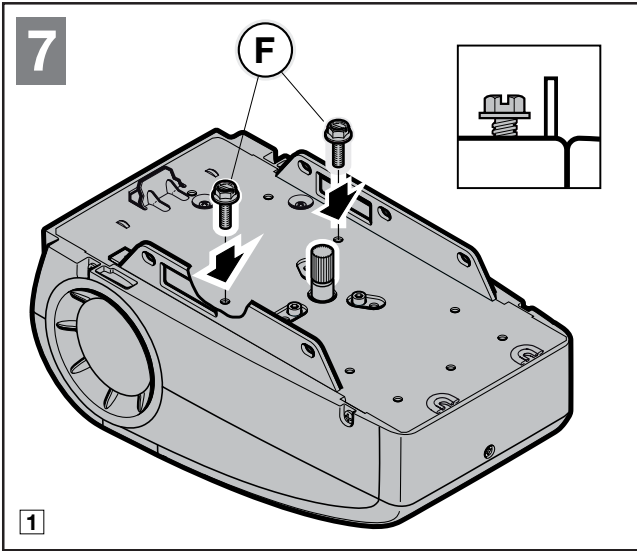



9

4.11

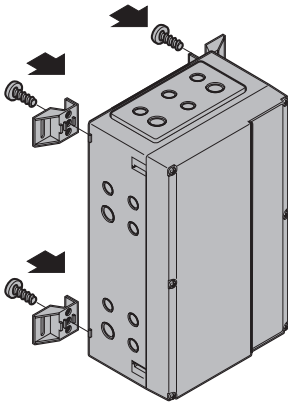

1

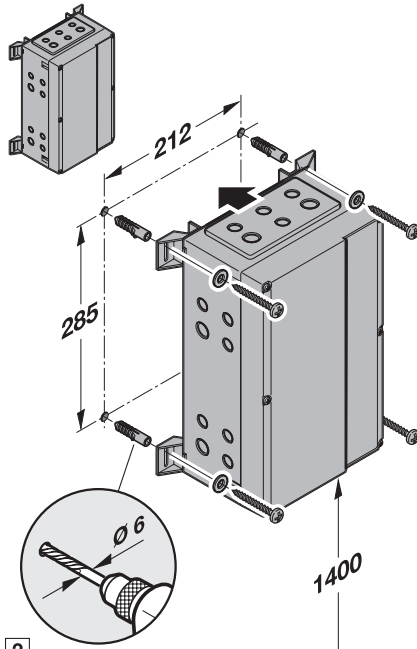

2

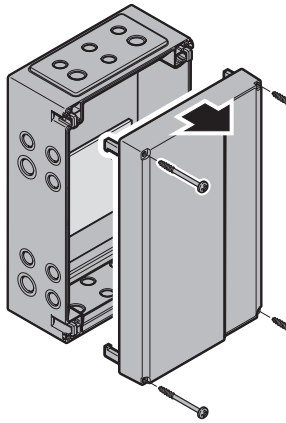
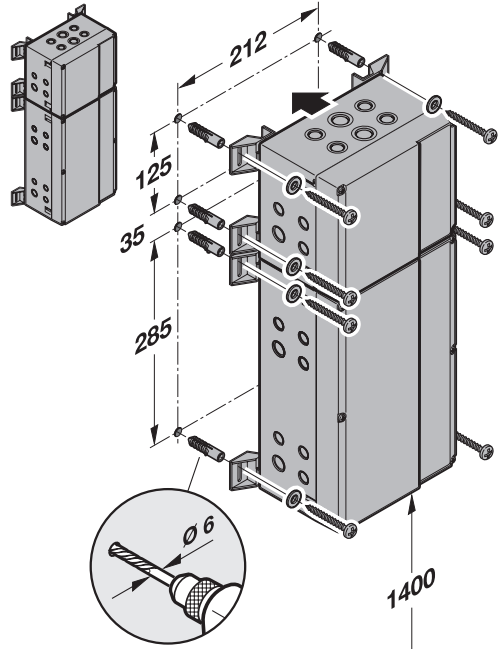

1

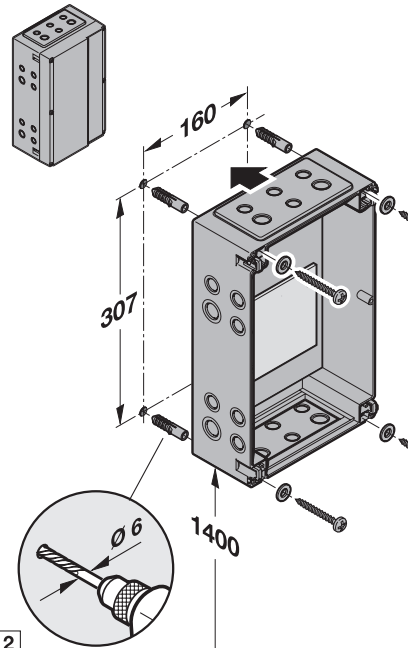

2

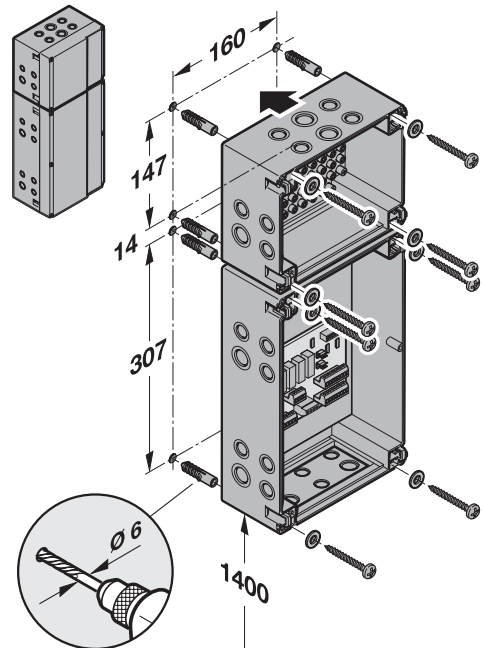

10

4.12

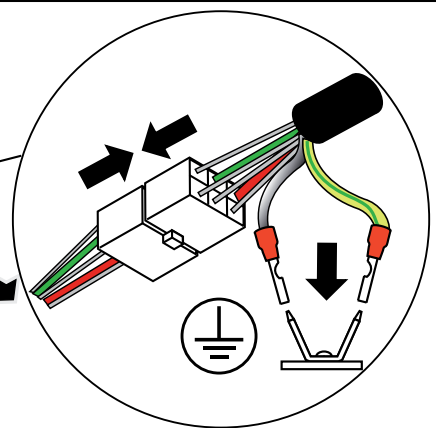
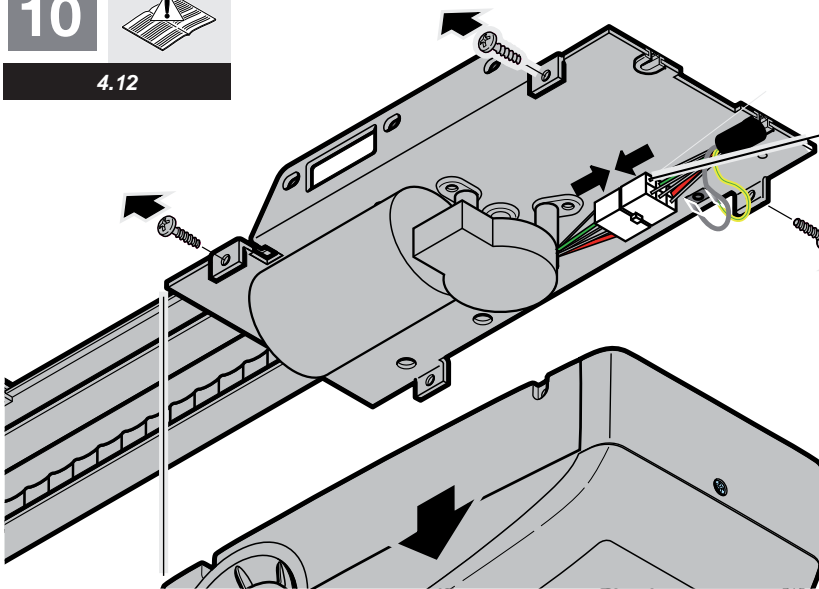



11



4.12

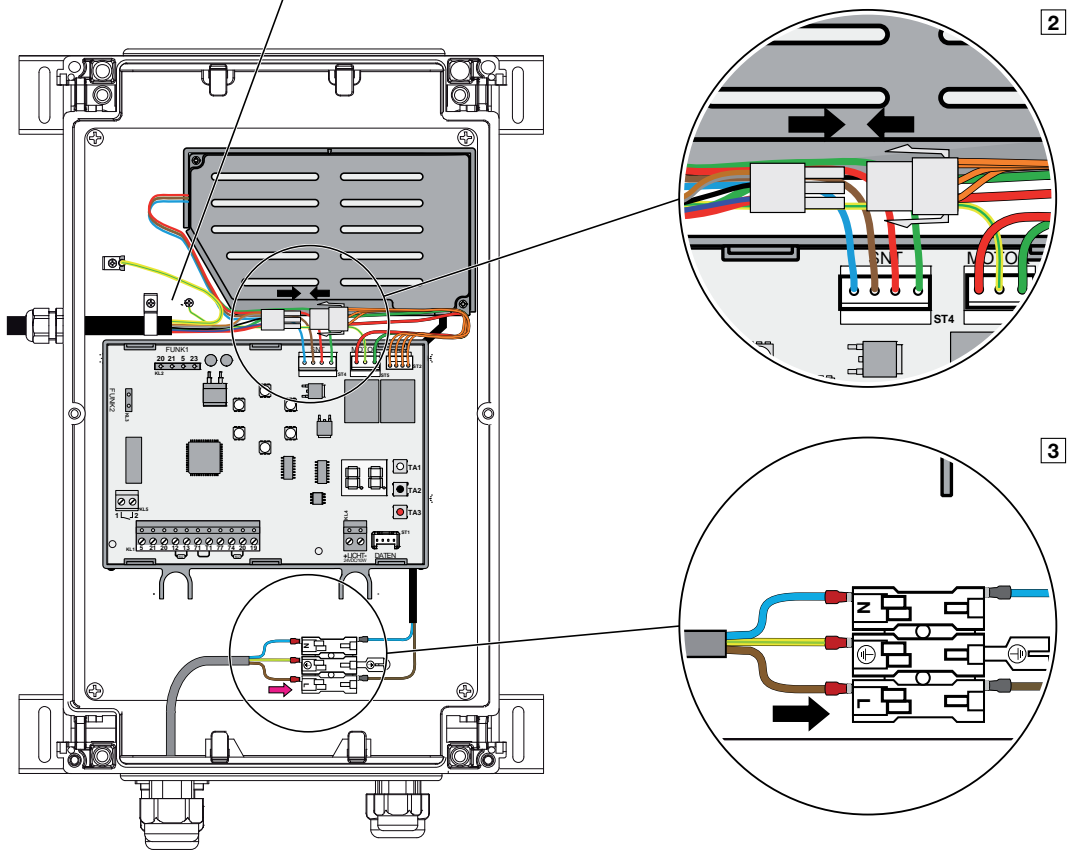
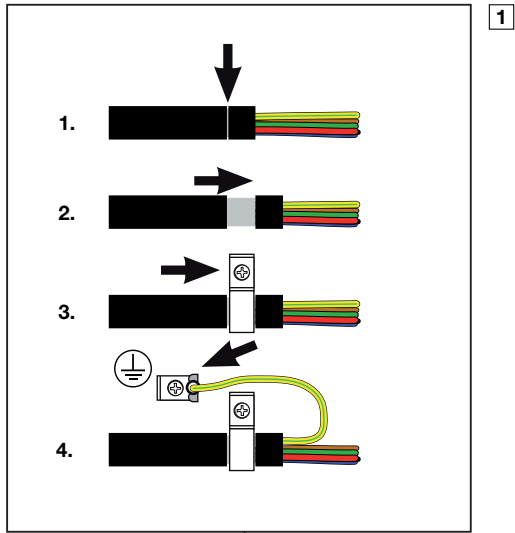



12



4.12.3

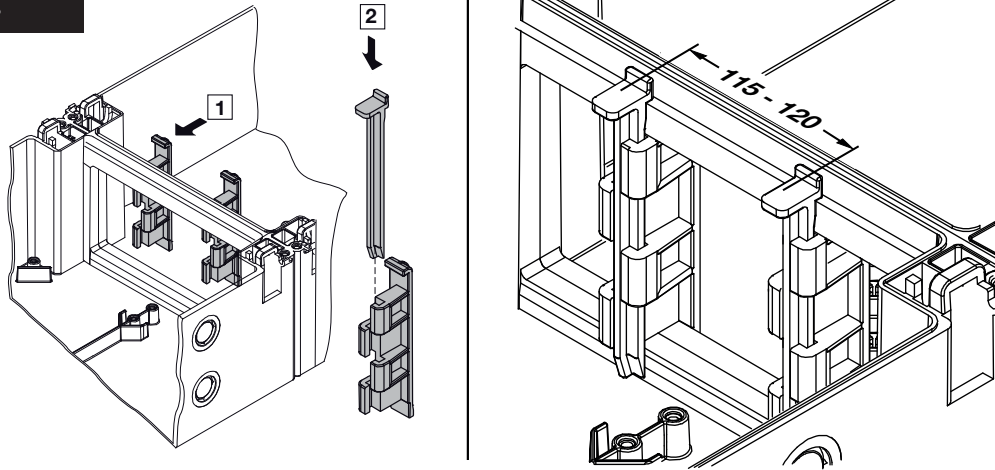

13



4.12.3

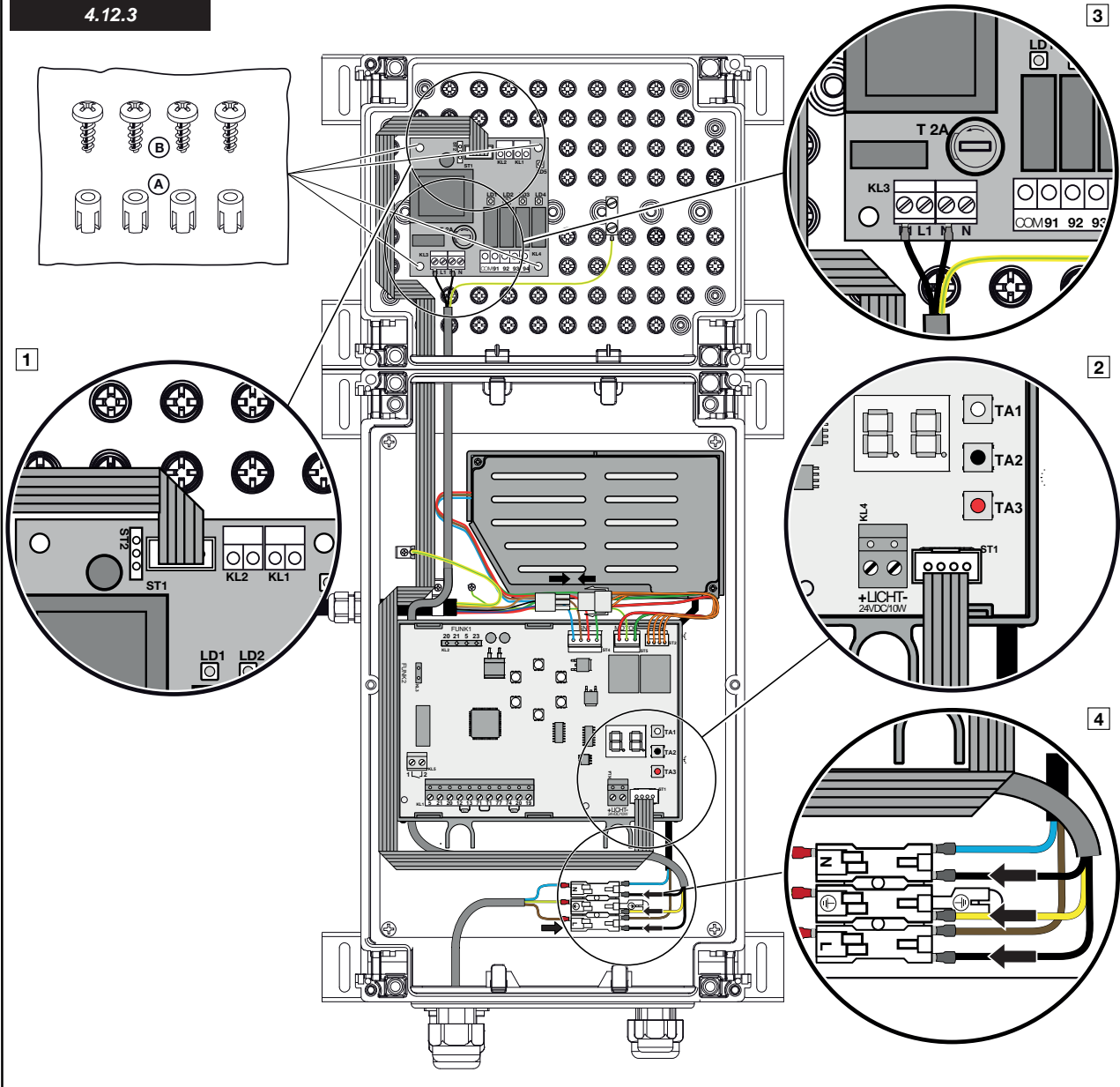

Handover report for garage door opener

- ▶ The door system and accessories listed below have been properly installed and the settings desired by the customer configured.
- ▶ The undersigned customer has been briefed on how to operate and maintain the door system and its accessories, with a particular focus on safety instructions.

Operator: Company/Name: _____
 Street: _____ Town/Post code: _____
 Telephone no.: _____ Contact: _____

Installation site: Company/Name: _____
 Same as operator Street: _____ Town/Post code: _____
 Telephone no.: _____ Contact: _____

Garage door type: Manufacturer: _____ Serial no.: _____
 Up-and-over door Model: _____ Year of construction: _____
 Sectional door
 Side-opening sectional door Dimensions: Width x Height in mm Weight: _____

Opener/Model: Serial no.: _____ Manufacturer: _____

Control system: Pulse operation Automatic operation Radio controlled

Settings / Menu	M			M			M			M			M			M			M		
	1	1		2	1		3	1		4	2		5	2		6	1		7	1	
	8	0		9	1		A	2		b	9		c	1		d	2		E	0	
	F	0		H	1		J	0		n	2		P	0							
Settings / Service menu	1	3		2	0		4	5		5	5		6	2		7	1		8	0	
	9	1		A	0		b	1		E	1		F	1		H	0				

Legend: **M** Menu number Factory setting Your setting

Accessories: Remote control _____ units Keypad Stop button
 Pushbutton Photocell Key switch
 Safety edge Wireless keypad Warning light
 Miscellaneous: _____

Operator: The door system and accessories listed above have been properly installed and handed over in fully functional condition. I was briefed on how to operate and maintain the system, and the complete installation and operating manual was handed over.

For address, see above

Date of handover: _____ Operator's signature: _____

Installation firm: Company/Name: _____
 Street: _____ Town/Post code: _____
 Telephone no.: _____ Fitter: _____

The opener and its accessories listed above were properly installed by me and handed over in fully functional condition. The customer was briefed on how to operate and maintain the system, and the complete installation and operating manual was handed over.

Date of handover: _____ Fitter's signature: _____

Instructions for Fitting, Operating and Maintenance
Garage door operator

GA403-403 TG

4Ddoors
GARAGE DOORS REDEFINED