

**Instructions for Fitting, Operating and Maintenance**  
Sliding operator

# CX1024

**4Ddoors**

GARAGE DOORS REDEFINED

[www.4Ddoors.com](http://www.4Ddoors.com)



# A

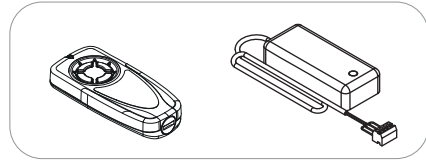
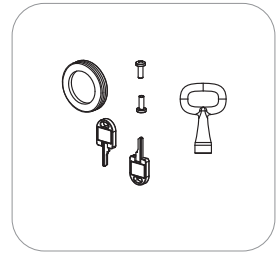
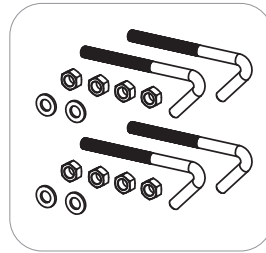
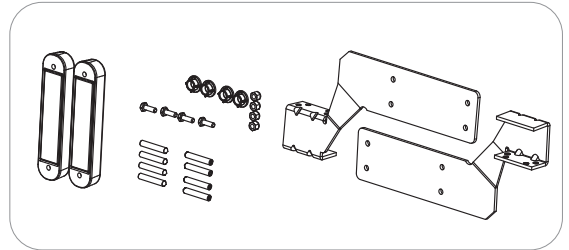
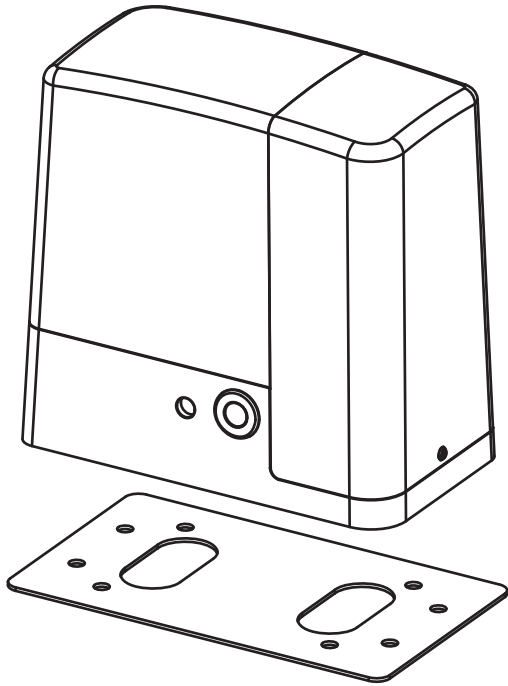

# B

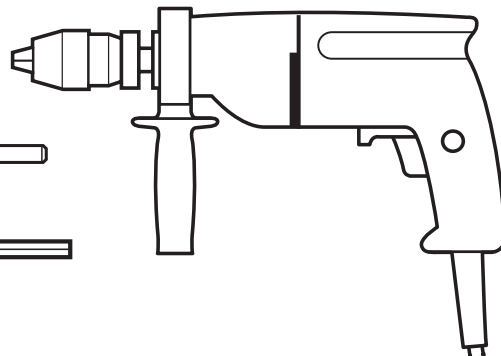
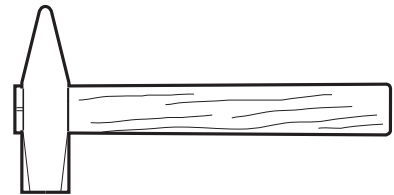
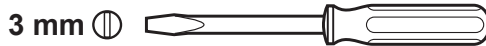
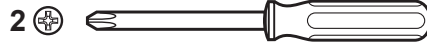



**C**

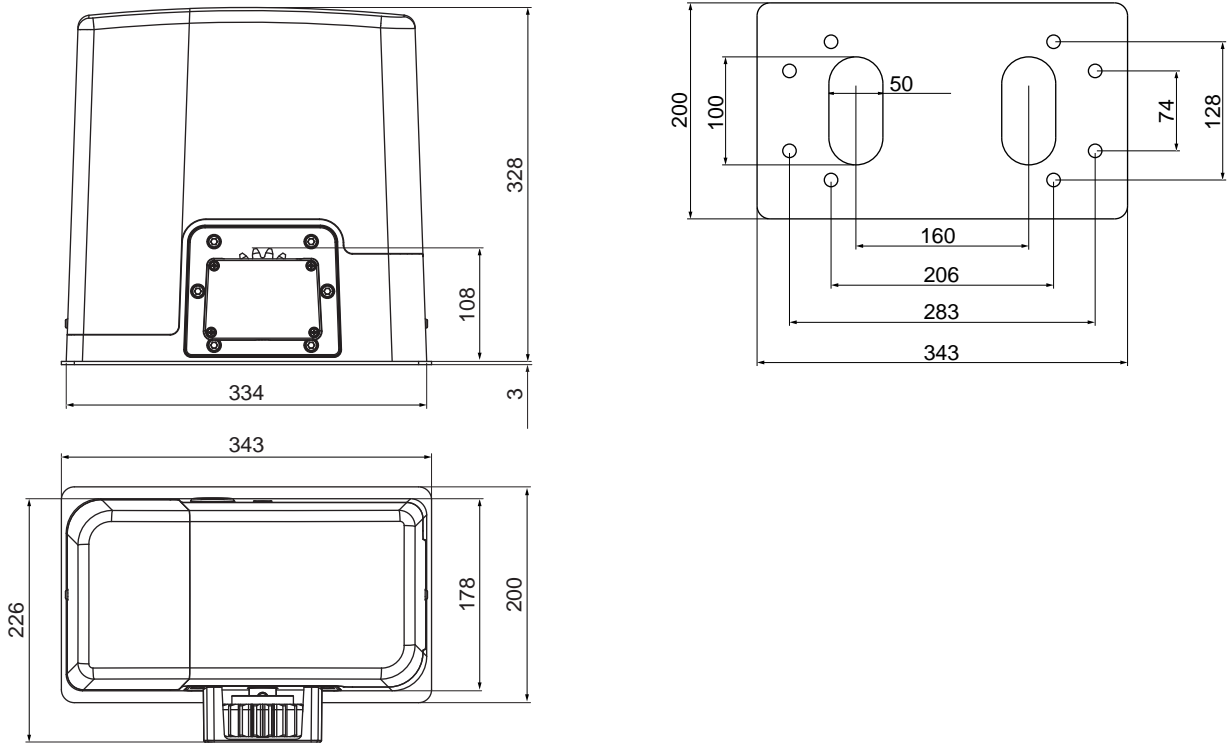

**D<sub>1</sub>**

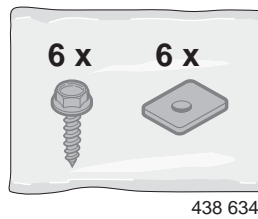

**D<sub>2</sub>**

438 632

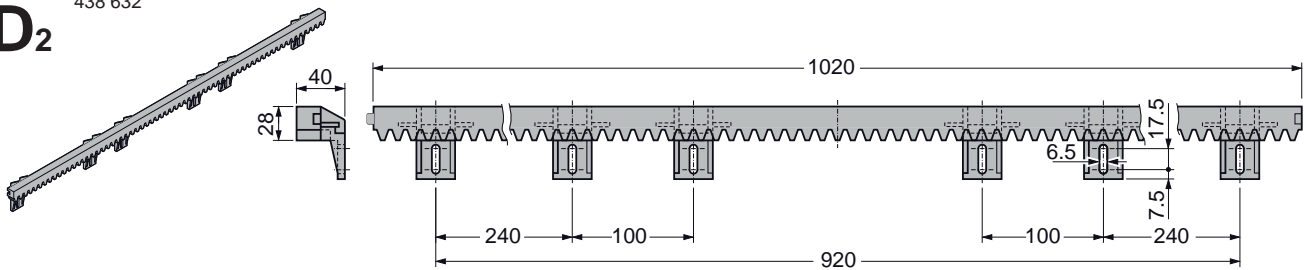

**D<sub>3</sub>**

438 631

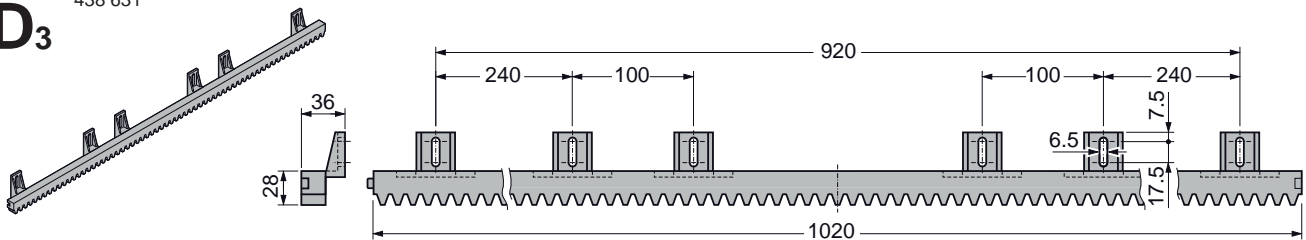

**D<sub>4</sub>**

2901624

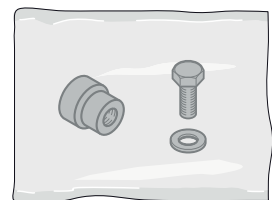
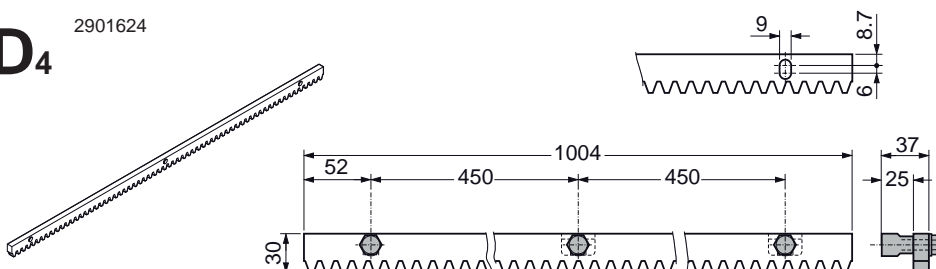

# Table of contents

<b>1</b>	<b>ABOUT THIS MANUAL</b>	<b>5</b>		
<b>2</b>	<b>NOTES</b>	<b>5</b>		
2.1	Applicable documents . . . . .	5		
2.2	Intended use . . . . .	5		
2.3	Unintended use . . . . .	5		
2.4	Installer qualification . . . . .	5		
2.5	Warning notices used . . . . .	5		
2.6	International colour code in accordance with IEC 757 . . . . .	5		
2.7	Symbols used . . . . .	5		
<b>3</b>	<b>SAFETY INSTRUCTIONS</b>	<b>6</b>		
3.1	Safety instructions for installation, maintenance, repair and disassembly of the gate system . . . . .	6		
3.2	Safety instructions for installation . . . . .	6		
<b>4</b>	<b>INSTALLATION</b>	<b>7</b>		
4.1	Checking and preparing the gate/gate system . . . . .	7		
4.2	Installing the sliding opener . . . . .	7		
4.3	Gear rack installation . . . . .	9		
4.4	Installing and adjusting the end position magnets . . . . .	11		
<b>5</b>	<b>COMMISSIONING/CONNECTING ADDITIONAL COMPONENTS</b>	<b>13</b>		
5.1	Information on electrical work . . . . .	13		
5.2	Electrical connection of the opener . . . . .	13		
5.3	Connecting the warning lights . . . . .	13		
5.4	Connecting external lighting . . . . .	14		
5.5	Command inputs . . . . .	14		
5.6	Stop input . . . . .	14		
5.7	Light barrier connection . . . . .	14		
5.8	Closing edge protection . . . . .	15		
5.9	Radio receiver . . . . .	15		
<b>6</b>	<b>STRUCTURE OF THE CONTROL</b>	<b>16</b>		
6.1	Display indicators . . . . .	16		
6.2	The <b>↑</b> and <b>↓</b> function buttons in normal mode . . . . .	16		
6.3	Buttons in programming mode and menu structure . . . . .	16		
6.4	Programming mode (main menu 1) . . . . .	16		
6.5	Settings in the function menu . . . . .	17		
6.6	Settings in the time menu . . . . .	17		
6.7	Settings in the value menu . . . . .	17		
6.8	Loading the standard values (main menu 5) . . . . .	17		
6.9	Starting the self teach-in function for the run times (main menu 4) . . . . .	17		
<b>7</b>	<b>CONFIGURING THE CONTROL</b>	<b>18</b>		
7.1	The configuration menu . . . . .	18		
7.2	Gate partially open position (pedestrian access) . . . . .	19		
7.3	Opening direction of the gate . . . . .	19		
7.4	Pre-warning period warning light (terminals E4/E5) in the open direction . . . . .	19		
7.5	Pre-warning period warning light (terminals E4/E5) in the close direction . . . . .	19		
7.6	Running speed in the open direction . . . . .	19		
7.7	Running speed in the close direction . . . . .	20		
7.8	Soft running speed . . . . .	20		
7.9	Start-up suppression . . . . .	20		
7.10	Warm-up ramp in the open direction . . . . .	20		
7.11	Warm-up ramp in the close direction . . . . .	20		
7.12	Soft stop in the open direction . . . . .	21		
7.13	Soft stop in the close direction . . . . .	21		
7.14	Start pulse (terminals J1/J4) when the gate is opening . . . . .	21		
7.15	Start pulse (terminals J1/J4) when the gate is closing . . . . .	21		
7.16	Start pulse (terminals J1/J4) when the gate is opening . . . . .	22		
7.17	Start pulse (START P, terminals J2/J4) with pedestrian opening . . . . .	22		
7.18	Automatic closing . . . . .	22		
7.19	Quick close after passage . . . . .	22		
7.20	Quick close after passage of both light barriers . . . . .	22		
7.21	Warning light (terminals E4/E5) during the pause time . . . . .	23		
7.22	Command inputs (terminals J1/J4, J2/J4) function . . . . .	23		
7.23	Stop input (terminals J3/J4) . . . . .	23		
7.24	Photocell 1 input (terminals J5/J9) . . . . .	24		
7.25	Photocell 2 input (terminals J6/J9) . . . . .	24		
7.26	Testing the safety devices . . . . .	24		
7.27	Closing edge protection 1 (terminals J7/J9) input . . . . .	24		
7.28	Closing edge protection 2 (terminals J8/J9) input . . . . .	25		
7.29	Evaluation of the closing edge protection . . . . .	25		
7.30	Obstacle sensor in the open direction . . . . .	25		
7.31	Obstacle sensor in the close direction . . . . .	25		
7.32	Obstacle sensor in the open direction . . . . .	26		
7.33	Obstacle sensor in the close direction . . . . .	26		
7.34	Function of the option relay (terminals B1/B2) . . . . .	26		
7.35	Radio receiver channel 2 function . . . . .	27		
7.36	Warning/signal light output function . . . . .	27		
7.37	ADI interface . . . . .	27		
7.38	End of programming . . . . .	27		
7.39	Reading the cycle counter . . . . .	28		
7.40	Indicating maintenance due . . . . .	28		
<b>8</b>	<b>OPERATION</b>	<b>29</b>		
8.1	Instructing personnel . . . . .	29		
8.2	Function check . . . . .	29		
8.3	Conduct in the event of/following a power failure . . . . .	29		
<b>9</b>	<b>INSPECTION, CHECKS AND MAINTENANCE</b>	<b>30</b>		
<b>10</b>	<b>MALFUNCTIONS</b>	<b>31</b>		
10.1	LED MAINS does not switch on . . . . .	31		
10.2	LED OVERLOAD switched on . . . . .	31		
10.3	Extended pre-warning period . . . . .	31		
10.4	Opener runs at minimum speed in the open and close direction . . . . .	31		
10.5	The gate does not open or close fully . . . . .	31		
<b>11</b>	<b>LOADING THE ERROR MEMORY (MAIN MENU 3)</b>	<b>31</b>		
<b>12</b>	<b>ERROR TABLE</b>	<b>32</b>		
<b>13</b>	<b>"-PRG" MENU FUNCTION OVERVIEW</b>	<b>34</b>		
<b>14</b>	<b>"-CNT" MENU FUNCTION OVERVIEW</b>	<b>36</b>		
<b>15</b>	<b>"-ERR" MENU FUNCTION OVERVIEW</b>	<b>36</b>		
<b>16</b>	<b>"-LRN" MENU FUNCTION OVERVIEW</b>	<b>36</b>		
<b>17</b>	<b>"-DEF" MENU FUNCTION OVERVIEW</b>	<b>36</b>		
<b>18</b>	<b>CONNECTION OVERVIEW</b>	<b>38</b>		
<b>19</b>	<b>CABLE LAYING DIAGRAM</b>	<b>40</b>		
<b>20</b>	<b>DISASSEMBLY AND DISPOSAL</b>	<b>41</b>		
<b>21</b>	<b>OPTIONAL ACCESSORIES</b>	<b>41</b>		
<b>22</b>	<b>WARRANTY CONDITIONS</b>	<b>41</b>		
<b>23</b>	<b>TECHNICAL DATA</b>	<b>41</b>		

**Dear customer**

**We are delighted that you have chosen one of our quality products.**

**1 ABOUT THIS MANUAL**

- This manual is a translation of the original manual within the sense of EC Directive 2006/42/EC. Read this manual carefully and fully. It contains important information regarding the product. Observe the information and, in particular, observe the safety and warning information.
- Please keep this manual in a safe place!
- Instructions in languages other than German are translations of this original manual.

**2 NOTES****2.1 Applicable documents**

The following documents must be available for the safe use and maintenance of the gate system:

- This manual
- The manual for the sliding gate

**2.2 Intended use**

- The opener may be used for private and commercial purposes.
- The sliding opener is only intended for operation of smooth-running sliding gates. The maximum permissible gate size and weight must not be exceeded.
- It must be possible to open and close the gate easily by hand.
- Please observe the manufacturer's information on possible gate and opener combinations. Possible hazards within the sense of DIN EN 13241-1 can be avoided by carrying out construction and installation in accordance with our specifications. Gate systems located in public areas which are only equipped with one safety device, e.g. force limitation, may only be operated under supervision.

**2.3 Unintended use**

- Continuous operation and use on gates with gradients or slopes is not permitted.
- **The sliding opener must not be operated in areas at risk of explosion.**
- The opener is not designed for operating sluggish/stiff gates, i.e. gates which cannot be opened or closed by hand, or only with difficulty.

**2.4 Installer qualification**

Only correct installation and maintenance, carried out by a competent/expert firm or individual in accordance with the manuals can ensure that an installation will proceed safely and as intended. In accordance with EN 12635, an expert is someone with appropriate education, qualified knowledge and practical experience to correctly and safely install, check and maintain a gate system.

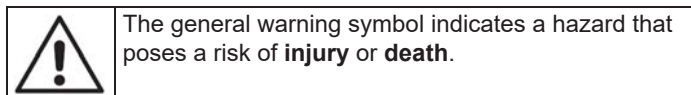
**2.5 Warning notices used**

The general warning symbol in conjunction with the warning levels described below are used in this manual.

	<b>DANGER!</b>
Indicates a hazard which poses an imminent risk of death or serious injury.	
	<b>WARNING!</b>
Indicates a hazard that poses a risk of death or serious injury.	
	<b>CAUTION!</b>
Indicates a hazard that poses a risk of minor or moderate injury.	
	<b>ATTENTION!</b>
Indicates a hazard that poses a risk of product damage or destruction.	

**2.6 International colour code in accordance with IEC 757**

<b>WH</b>	White	<b>GN</b>	Green
<b>BN</b>	Brown	<b>YE</b>	Yellow
<b>BK</b>	Black	<b>RD</b>	Red
<b>OG</b>	Orange	<b>BU</b>	Blue
<b>GY</b>	Grey	<b>VT</b>	Violet
<b>RS</b>	Pink		

**2.7 Symbols used**

	2.5	= See Section 2.5
		= Factory setting

### 3 SAFETY INSTRUCTIONS



## WARNING!



**Risk of injury from unintentional gate movement!**  
In the event of improper installation or operation of the opener, unintentional gate movements may be triggered which may cause people or objects to become trapped.

In the event of improperly attached control units (e.g. buttons), unintentional gate movements may be triggered which may cause people or objects to become trapped.



- ▶ Follow all instructions contained in this manual.
- ▶ Attach control units at a height of minimum 1.5 m (outside of the reach of children).
- ▶ Install fixed control units (e.g. buttons) within sight of the gate but away from moving parts.

In the event of the failure of safety devices, persons or objects may become trapped.

- ▶ In accordance with ASR 1.7, install at least one easily identifiable and accessible emergency command device (emergency stop) in the vicinity of the gate, which may be used to stop the gate in the event of danger.

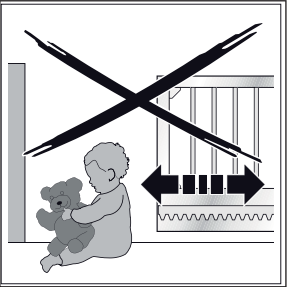

## WARNING!

**Risk of injury when the gate is moving!**  
A moving gate can give rise to injury or damage in the gate area.

- ▶ Do not allow children to play on the gate system.
- ▶ Ensure that no persons or objects are located within the movement area of the gate.
- ▶ In the event that the gate system is equipped with only one safety device, operate the sliding opener only when you can clearly see the movement area of the gate.
- ▶ Monitor movement of the gate until it has reached its end position.
- ▶ Only pass or walk through gate openings of remote-controlled gate systems if the gate is stationary!
- ▶ Never stand within the open gate.

#### 3.1 Safety instructions for installation, maintenance, repair and disassembly of the gate system

The installation, maintenance, repair and disassembly of the gate system and the sliding opener must be performed by expert personnel.

- ▶ In the event of the failure of the gate system or the sliding opener (sluggishness or other faults), always commission expert personnel immediately to inspect and repair the system.

#### 3.2 Safety instructions for installation

- The expert must ensure that the applicable regulations concerning safety at work and rules on the operation of electrical equipment must be observed during installation work. To this end, the national guidelines must be followed. Possible hazards per DIN EN 13241-1 can be avoided by carrying out construction and installation in accordance with our specifications.
- After completing installation, the installer of the gate must declare conformity with DIN EN 13241-1 in accordance with the scope of application.
- **Before commencing electrical work, ensure that the system is fully de-energised and secure it against unauthorised re-activation.**

## 4 INSTALLATION

### ATTENTION:

IMPORTANT INSTRUCTIONS FOR SAFE INSTALLATION. OBSERVE ALL INSTRUCTIONS, INCORRECT INSTALLATION CAN LEAD TO SERIOUS INJURY.

### 4.1 Checking and preparing the gate/gate system

## WARNING!

### Risk of injury from gate system faults!

A fault in the gate system or an improperly aligned gate can lead to serious injury.

- ▶ Do not use the gate system if repair or adjustment work needs to be performed.
- ▶ Check the entire gate system (hinges, gate mounting and fasteners) for wear and potential damage.
- ▶ Check for rust, corrosion or cracks.

The sliding opener is not designed for operating sluggish/stiff gates, i.e. gates which cannot be opened or closed by hand, or only with difficulty.

The opener is only suitable for gates which do not exhibit gradients or slopes.

The gate must be mechanically sound so that it can be easily operated by hand (EN 12604).

- ▶ Check that the gate can be opened and closed properly.
- ▶ Put mechanical gate locks which are not required for operation with a sliding opener out of operation. This includes, in particular, the locking mechanisms of the gate lock.
- ▶ Secure the gate mechanically to prevent it from overrunning its guides.

### 4.2 Installing the sliding opener

## WARNING!

### Risk of injury from unintentional gate movement

In the event of improper installation or operation of the opener, unintentional gate movements may be triggered which may cause people or objects to become trapped.

- ▶ Follow all instructions contained in this manual. Danger of crushing and shearing! Never grab hold of the main or secondary closing edges when the gate is moving!

#### 4.2.1 Foundation for the sliding opener

## ATTENTION!

### Faults in the control lines

Control lines and supply lines routed together can lead to malfunctions.

- ▶ Route the control lines of the opener (24 V DC) in a separate installation system to the supply lines (230/240 V AC).

- A foundation must be cast for the sliding opener, as shown in Figure 1. The marking ⊛ indicates the frost-free depth (in Germany = 80 cm).
- Concrete ≥ B25/C25 (compacted) is required.
- Gates with interior rollers may require a plinth foundation.

- The 230/240 V mains supply line must pass through an empty conduit in the foundation. The supply line for connection of 24 V accessories must pass through a separate empty conduit separated from the mains supply line.

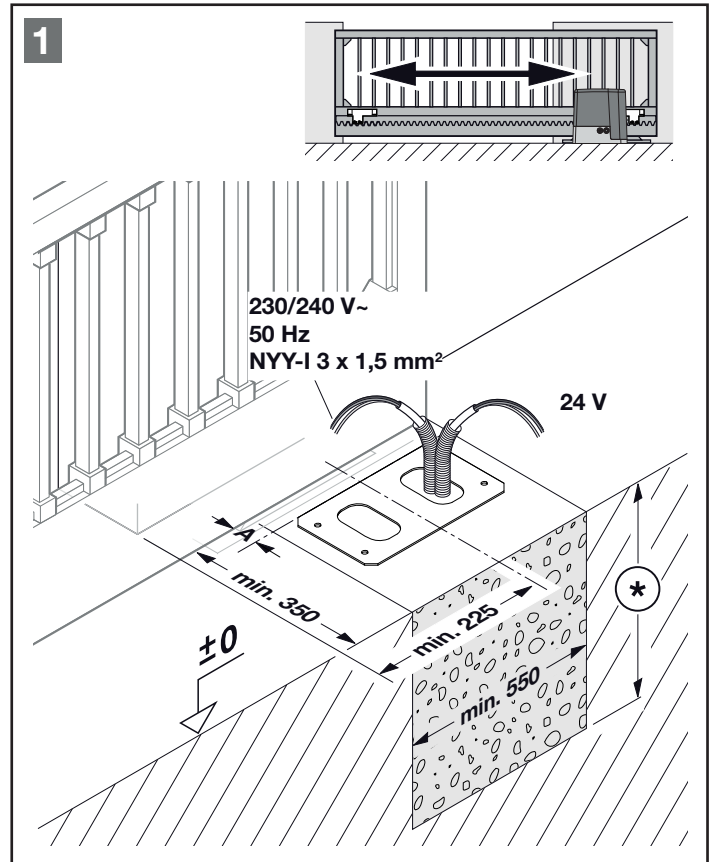

Figure 1 - Foundation

#### 4.2.2 Inserting the base plate

Prepare the concrete foundation in accordance with the installation dimensions. Secure the ground anchor in the holes in the metal base plate and insert into the cement surface.

Always observe the installation dimensions! See "Figure 1 - Foundation" and "Figure 2 - Ground anchor".

The attachment base must be completely level and clean over its entire length.

The screw threads of the floor anchor, as well as the empty conduits/cables for electrical connection, must protrude fully.

## WARNING!

### Unsuitable fixing materials

Use of unsuitable fixing materials can lead to the opener being insecure and coming loose.

- The installer must verify the suitability of the supplied installation materials for the installation location.

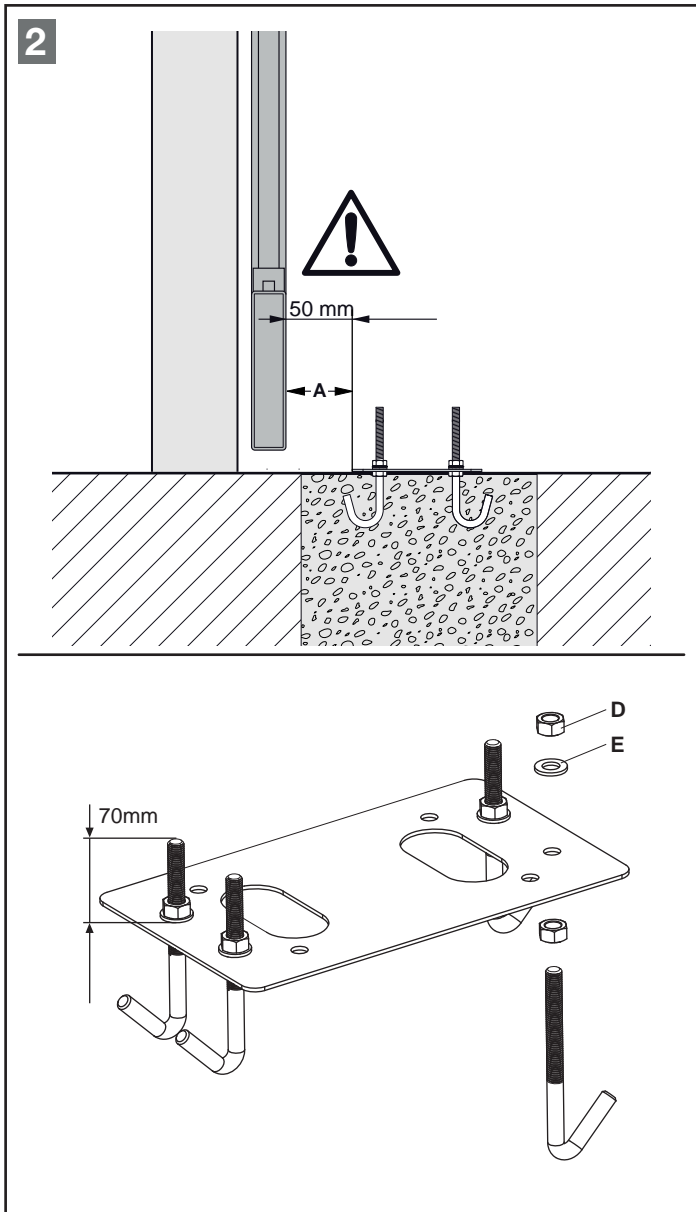

Figure 2 - Ground anchor

**Note**

The foundation must be allowed to harden sufficiently before installation.

**4.2.3 Fixing the motor base plate to an existing concrete foundation**

Before drilling the four holes, their position must be marked on the surface of the foundation. Use the motor base plate as a drilling pattern. Always observe the installation dimensions! See “Figure 1 - Foundation” and “Figure 2 - Ground anchor”. Then drill plug holes, clean the holes and fix the base plate with suitable installation materials. Ensure to tighten the nut and washer to the ground.

	<b>ATTENTION!</b>
<p><b>Damage from dirt</b>                  Drilling dust and chips can lead to malfunctions.                  ► Cover the opener when drilling.</p>	

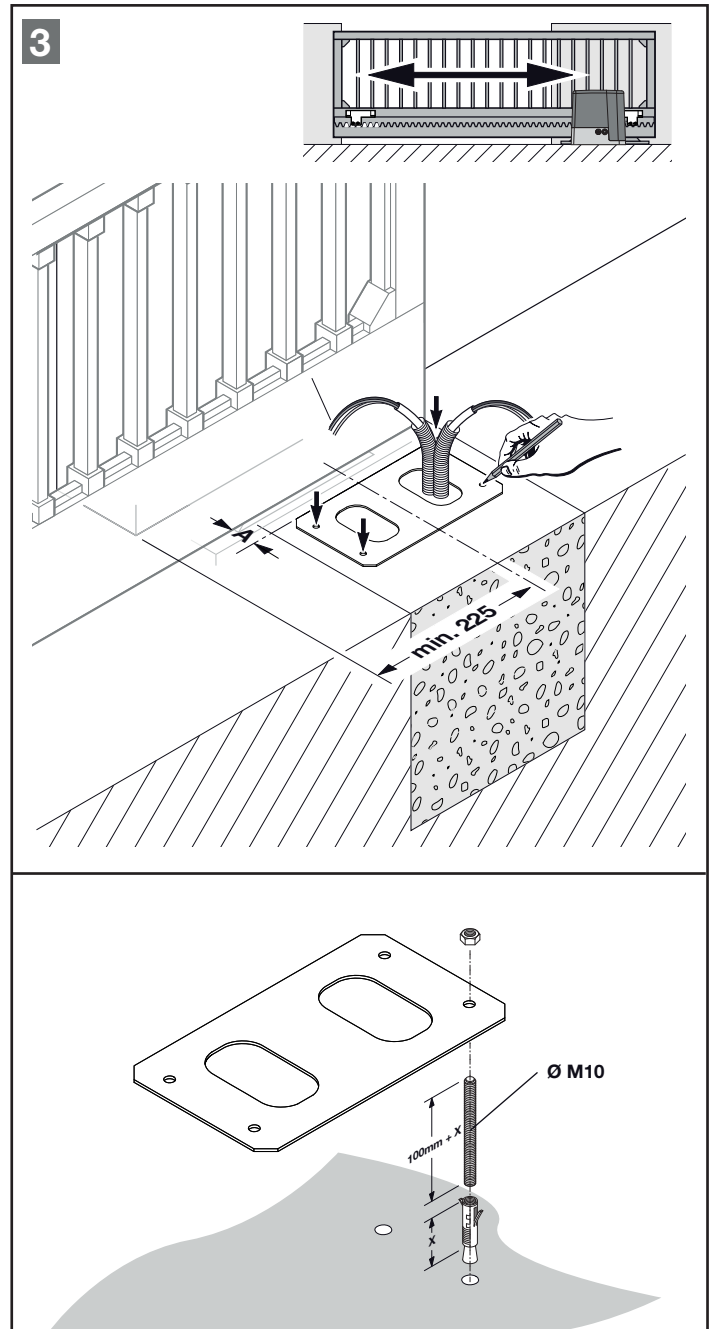

Figure 3 - Heavy load anchor

**4.2.4 Opening the opener housing**

The cover of the housing must be opened for the sliding opener to be installed.

	<b>ATTENTION!</b>
<p><b>Potential damage from penetrating moisture!</b>                  ► Protect the control from moisture when opening the sliding opener.</p>	



#### 4.2.5 Installing the opener housing

- Remove the 4 nuts (D) and washers (E) used to fix the base plate to the ground anchors during foundation works.
- Cut the empty conduit seal (F) according to the connection lines and install in the opener housing. Ensure that the holes are not too large that insects may be able to crawl through.
- When positioning the housing on the floor anchors or on the threaded rods of the heavy load anchor, pull the supply line and other connection lines through the empty conduit seal into the housing from below, ensuring that there is no warping.
- Position the opener on the threaded bolts of the base plate, align parallel to the gate and adjust the height using the 4 height adjustment screws (G). Then fix the opener motor.

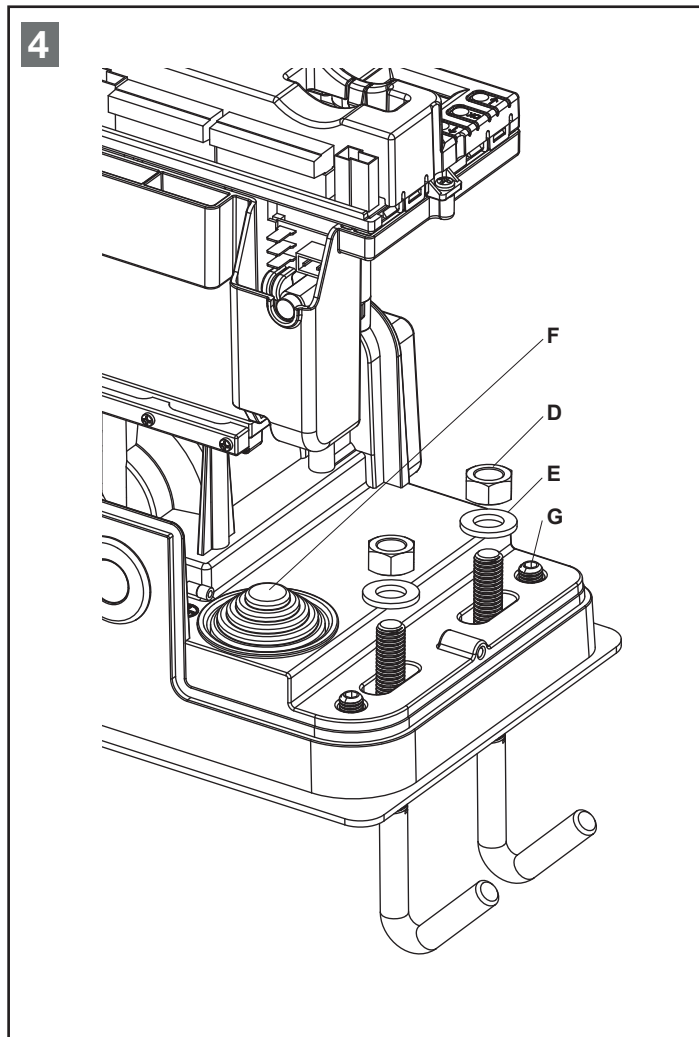

Figure 4 - Fixing

#### Note

When tightening, ensure a level, stable and secure fixing. A minimum clearance of 5 mm between the anti-trap protection and gate panel must be adhered to over the entire length of the gate, see **“Figure 5 - Aligning the opener”**.

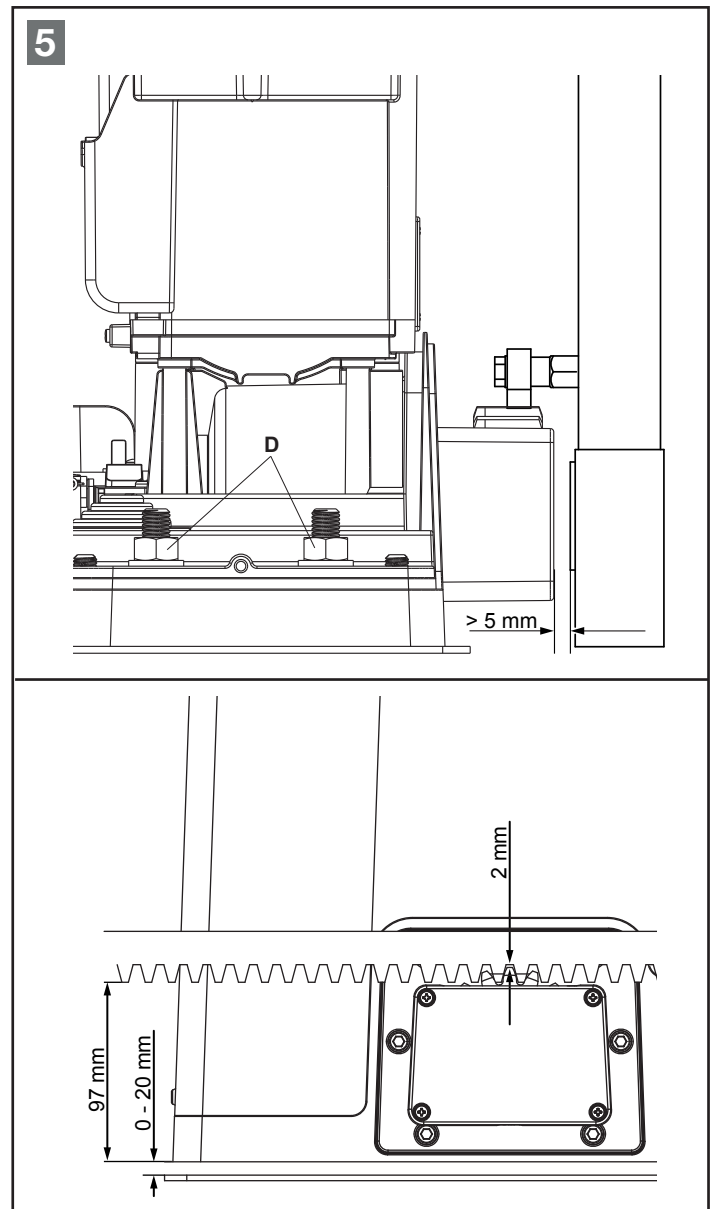

Figure 5 - Aligning the opener

#### 4.3 Gear rack installation

#### Note

Unlock the sliding opener before installing the gear racks, see **“Figure 8 - Unlocking the opener”**.

- Using the height adjuster, raise the opener by approx. 5 mm and fix the motor to the base plate.
- Unlock the opener.
- Rest the gear rack against the opener pinion and by sliding the gate manually, install the gear rack metre by metre to the gate. Fix the gate rack in alignment with the opener pinion.
- Adjust the opener using the height adjustment screws (G) so that there is gap of 1 - 2 mm between the rack and pinion. This prevents the weight of the gate from exerting a load on the opener.

**ATTENTION!**  
 Incorrectly installed or improperly aligned gear racks can lead to malfunctions. The specified dimensions must be observed!

**ATTENTION!**  
**Damage from dirt and flying sparks**  
 Drilling dust, chips and flying sparks can lead to malfunctions and/or corrosion.  
 ► Cover the opener when drilling and welding.

**ATTENTION!**  
 Use the plastic gear rack only on smooth-running gates and gates intended for private use. The max. gate weight of 1000 kg must not be exceeded!

**Note**  
 In deviation from the figure, suitable connecting elements must be used on other gate types (e.g. use corresponding woods screws on wooden gates), different screw-in lengths may also be required. In deviation from the figure, the requisite core hole diameter may vary according to the material thickness or strength. The requisite diameter may be  $\varnothing 5.0 - 5.5$  mm for aluminium and  $\varnothing 5.7 - 5.8$  mm for steel.

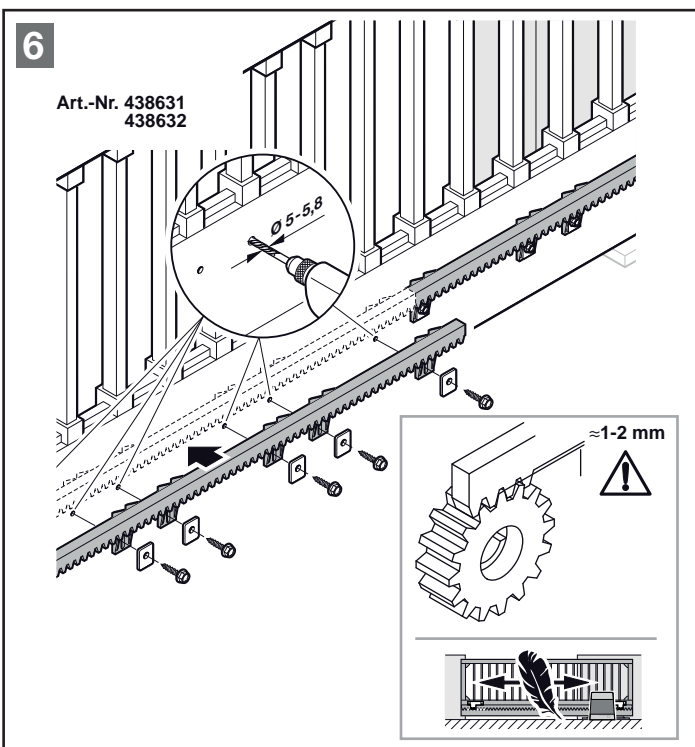

Figure 6 - Installing the plastic gear rack

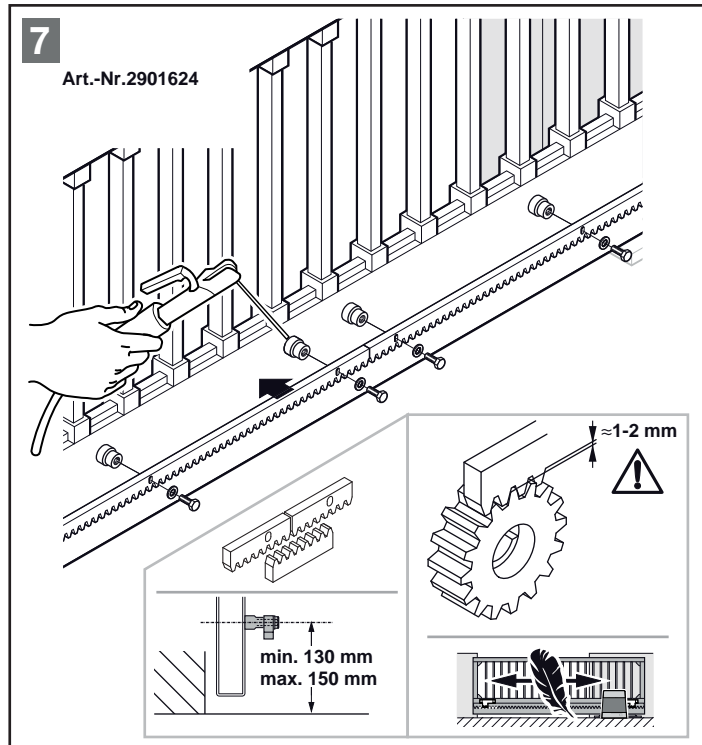

Figure 7 - Installing the steel gear rack

**Note**  
 When installing metal gear racks on a meter grid, ensure that they are not installed flush, note the continuation of the toothing. To check a gear rack, counter/hold it from below. See "Figure 7 - Installing the steel gear rack".

### 4.3.1 Actuating the emergency release

In the event of a power failure or malfunction, the opener motor can be unlocked. To do this, proceed as follows:

- Turn the cover flap (K) over the lock to the side.
- Insert the key (I, supplied) into the lock and turn in a clockwise direction to open the lock cover of the emergency release.
- Insert the triangular key (J, supplied) into the emergency release lock and turn in a clockwise direction as far as it will go.
- The sliding gate can now be moved by hand.

To lock the opener again, proceed as follows:

- To lock, insert the triangular key (J, supplied) into the emergency release lock and turn in an anticlockwise direction as far as it will go.
- Move the gate by hand until it audibly engages.
- Close the lock cover of the emergency release and the cover flap (K).

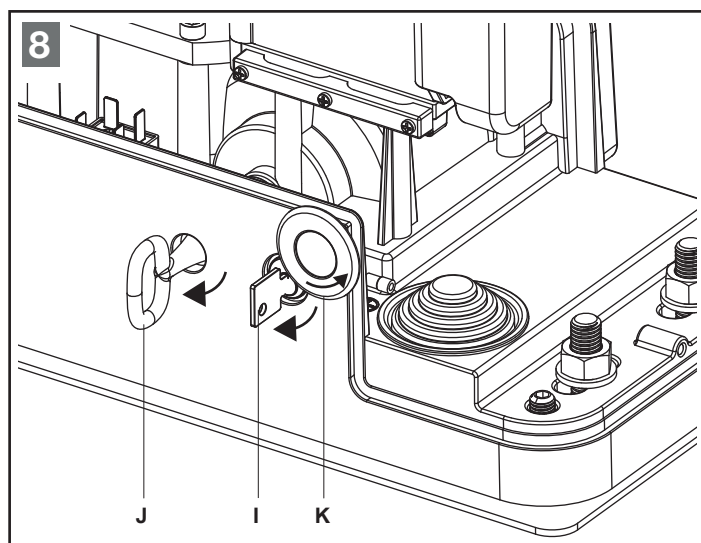

Figure 8 - Unlocking the opener

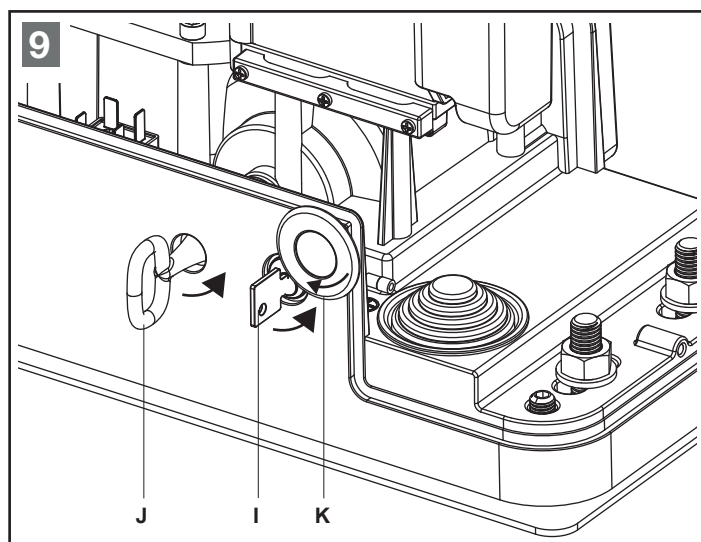

Figure 9 - Locking the opener

### 4.4 Installing and adjusting the end position magnets



## WARNING!

#### Falling out

- Overrunning the limit switches can cause the gate to fall out.
- A mechanical limit stop must be installed in the open and closed end positions as an overrun protection.

Firstly, fix the two magnet holders in the corresponding end positions on the gear rack using the screws supplied. Then install the magnets in the holders, ensuring that the red magnet (SX) is installed on the left and the blue magnet (DX) is installed on the right (see "**Figure 11 End positions**"). Determine the correct distance to the two reed contacts. To do this, unlock the opener and slide the gate into the gate open and gate closed end positions.

Monitor the limit switch display on the control, if the gate open or gate closed indicator appears, the magnet in the reed contact has been detected. Move the magnet holders to correct. The magnet holders can be permanently fixed in place following a successful test run.

#### Note

The correct distance between the magnet and reed contact depends on the installation situation and cannot be determined in advance, only by testing. The distance must be a minimum of 38 mm, a larger distance can prevent magnet detection. See "**Figure 12 - Distances**".

#### Note

The opener must be adjusted such that the gate is **not** pressed against the mechanical limit stop in the end positions and a distance of approx. 10 - 30 mm is maintained.

#### Note

Seal the housing against moisture and insects. See "**Figure 10 - Sealing**".

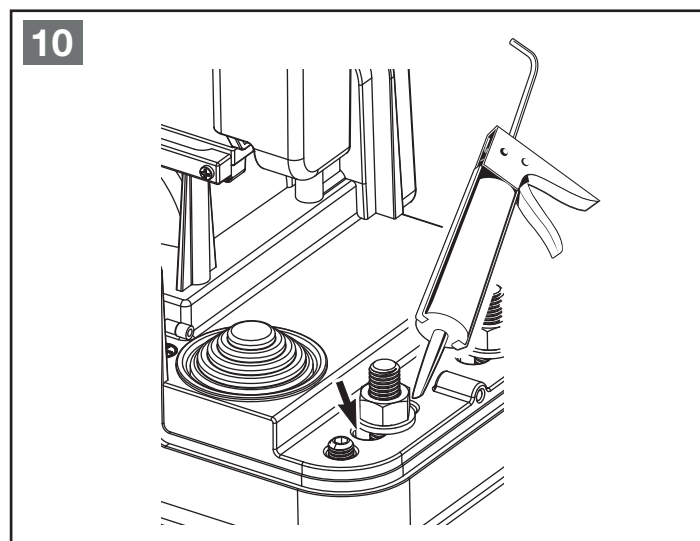

Figure 10 - Sealing

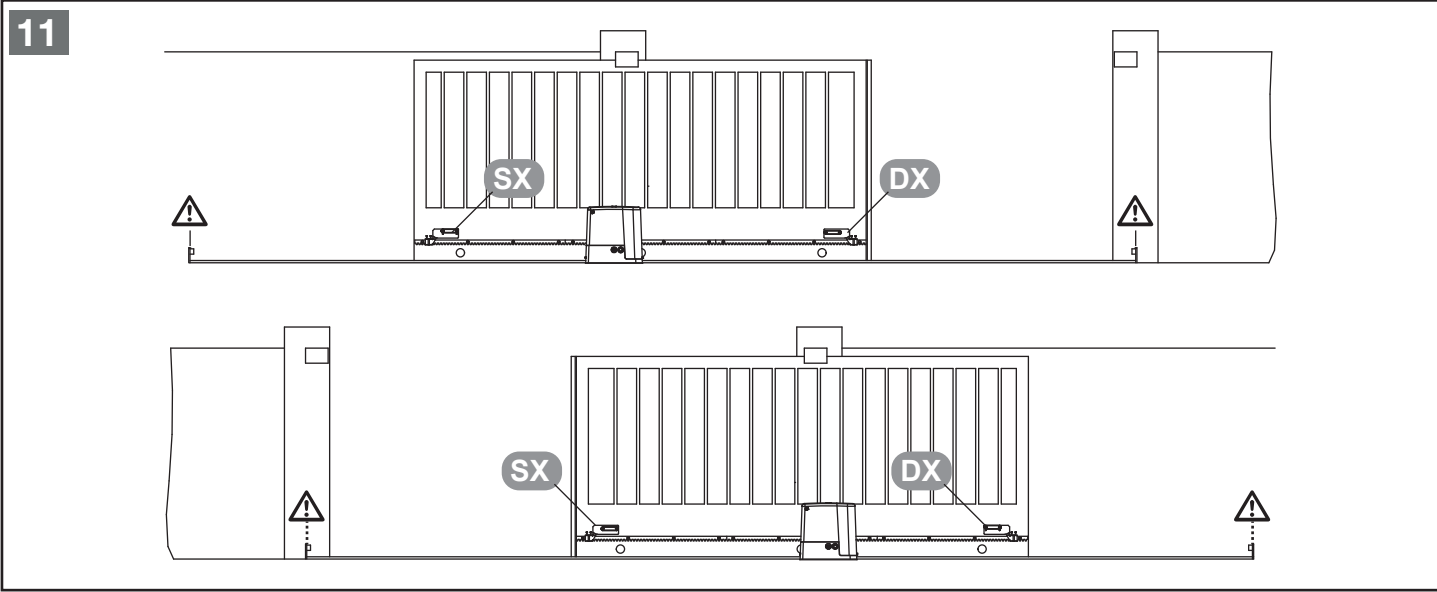

Figure 11 End positions

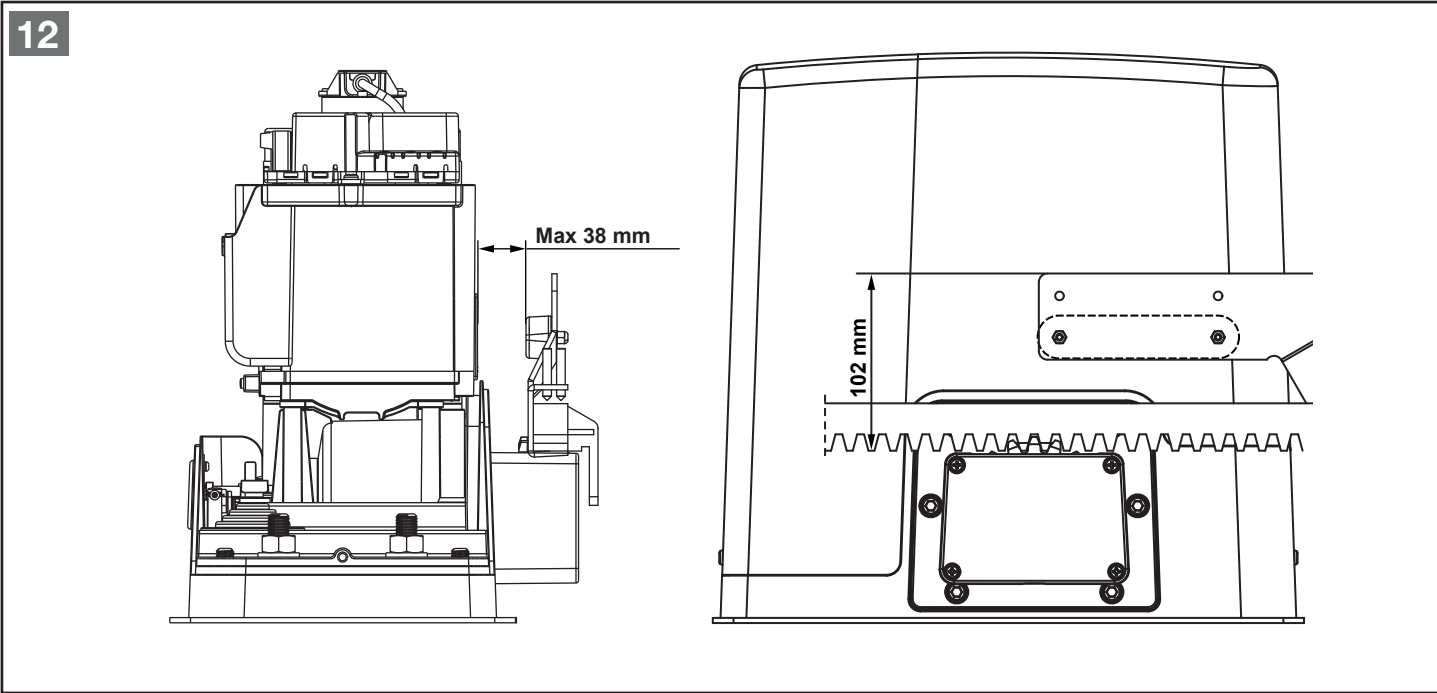

Figure 12 - Distances

## 5 COMMISSIONING/CONNECTING ADDITIONAL COMPONENTS

### 5.1 Information on electrical work

# DANGER!

#### Power supply

Contact with the power supply poses a risk of fatal electric shock.

Always observe the following information:

- ▶ Electrical connections may only be established by a qualified electrician.
- ▶ The on-site electrical installation must comply with the respective safety regulations (230/240 V AC, 50/60 Hz).
- ▶ Before commencing electrical work, ensure that the system is fully de-energised and secure it against unauthorised re-activation.

# ATTENTION!

- Applying external voltage to the connection terminals of the control system will destroy the electronics!
- To avoid malfunctions, ensure that the control lines of the opener (24 V DC) are laid in an installation system separate from the other supply lines (230 V AC)!

# WARNING!

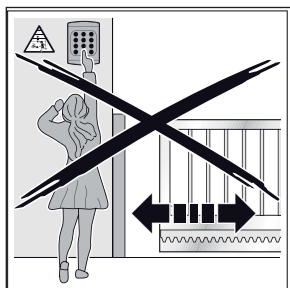

**Risk of injury from unintentional gate movement!**  
In the event of improper installation or operation of the opener, unintentional gate movements may be triggered which may cause people or objects to become trapped.

In the event of improperly attached control units (e.g. buttons), unintentional gate movements may be triggered which may cause people or objects to become trapped.

- ▶ Follow all instructions contained in this manual.
- ▶ Attach control units at a height of minimum 1.5 m (outside of the reach of children).
- ▶ Install fixed control units (e.g. buttons) within sight of the gate but away from moving parts.

In the event of the failure of safety devices, persons or objects may become trapped.

- ▶ In accordance with ASR 1.7, install at least one easily identifiable and accessible emergency command device (emergency stop) in the vicinity of the gate, which may be used to stop the gate in the event of danger.

### 5.2 Electrical connection of the opener

The mains connection (230 V AC/50 Hz) of the opener requires a line NYY 3 x 1.5 mm<sup>2</sup> (to 20 m supply line) or NYY 3 x 2.5 mm<sup>2</sup> (to 30 m supply line). The supply line must be secured with an ELCB (30 mA) in accordance with the statutory requirements. In accordance with ASR 1.7, an all-pole-disconnecting lockable main switch must be installed in the area of the opener between the mains supply line and the supply line to the opener. Connect the supply line to terminals **L** and **N** on the power board and the protective conductor **PE** to the protective conductor connection of the opener housing.

See "**Figure 13 - Opener mains connection**".

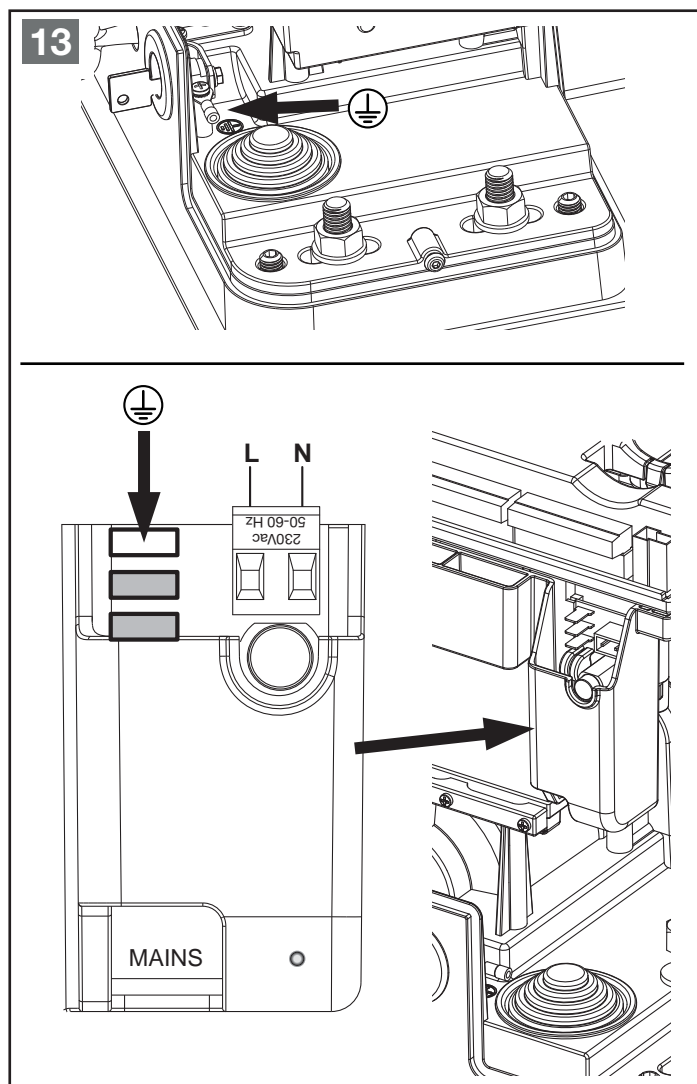

Figure 13 - Opener mains connection

#### Note

The remaining accessories may only be connected following a complete test run in conjunction with the motor control, command unit and correct limit switch adjustment.

### 5.3 Connecting the warning lights

A warning light (e.g. SLK-L) may be connected to the control. Connect the warning light (**24 V DC/max. 3 W**) to terminals **E4** and **E5** (**not floating, 24 V DC**). The function is set in menu **P44**.

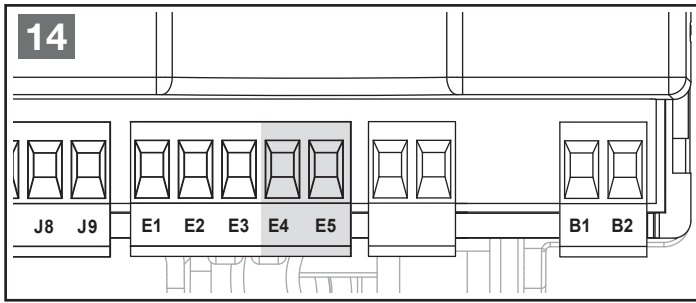

Figure 14 - Connecting the signal light 24 V DC

#### 5.4 Connecting external lighting

External lighting may be connected to the control. Connect the external lighting to terminals **B1** and **B2** (floating relay output), **max. 230 V AC/40 W**.

The function is set in menu **P42**.

##### Note

A warning light or warning beacon may also be connected to the option relay if the function **t.Lic** has been set to time **0.5"** in menu **P42**. The relay is activated when the gate is moving and switches off after 0.5 sec once the end position/intermediate position has been reached.

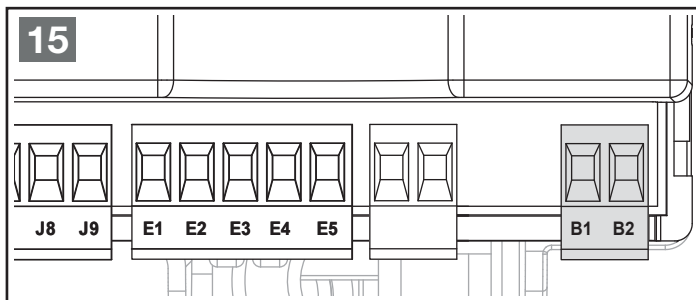

Figure 15 - Connecting the lighting

#### 5.5 Command inputs

The control has two command inputs which may be programmed differently (see menu **P28**):

##### Standard mode:

- A command at the **START** input opens/closes the gate.
- A command at the **START P** input opens/closes the gate for the distance set in menu **P03** (pedestrian opening).

##### Open/close mode:

- A command at the **START** input opens the gate.
- A command at the **START P** input closes the gate.

##### Deadman operation mode:

- A command at the **START** input opens the gate if the contact is closed.  
If the contact is opened, the gate stops immediately.
- A command at the **START P** input closes the gate if the contact is closed.  
If the contact is opened, the gate stops immediately.

##### Time mode (continuous open):

- A continuous command at the **START** input opens the gate or holds the gate open for the duration of the continuous command.
- A continuous command at the **START P** input opens the gate or holds the gate open in the pedestrian position for the duration of the continuous command.
- After opening the continuous command, the gate closes upon expiry of the hold-open and pre-warning time.

##### Note

Time mode functions only in conjunction with set automatic gate closing, menu **P24**.

- Connect the floating normally open contact for the **START** command to terminals **J1** and **J4**.
- Connect the floating normally open contact for the **START P** command to terminals **J2** and **J4**.

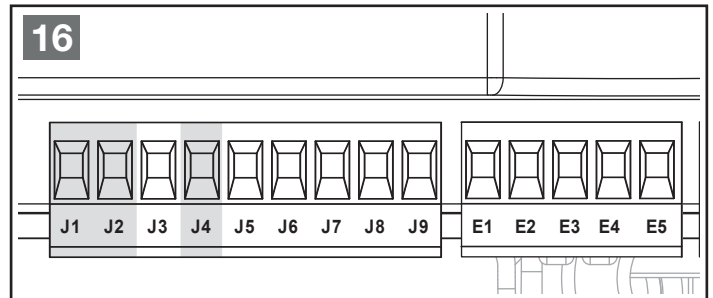

Figure 16 - Connecting the button

##### Note

The button **↑** or **channel 1** of the radio receiver has the same function as the **START** input.

The button **↓** or **channel 2** of the radio receiver has the same function as the **START P** input.

#### 5.6 Stop input

A stop button with floating normally closed contact may be connected to the control.

On actuation, movement of the gate is stopped immediately.

- Connect the floating normally closed contact to terminals **J3** and **J4**.

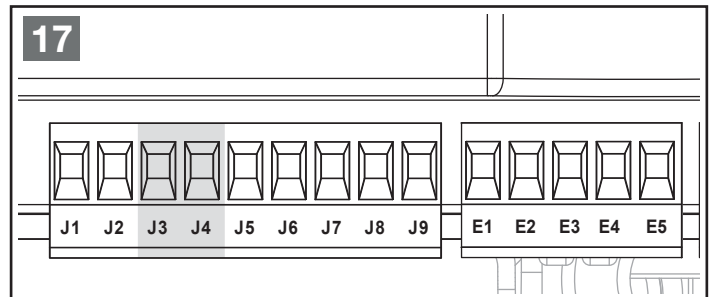

Figure 17 - Stop input

##### Note

No closing takes place upon expiry of the hold-open time when automatic gate closing is activated when the gate is moving or with the gate open and the stop button being actuated.  
A new start command must be given.

#### 5.7 Light barrier connection

The control has two safety inputs for photocells which can be divided into different categories.

- **Photocell type 1:** The light barrier is installed on the inside of the gate system and is active in both the open and close direction. If photocell type 1 is triggered, the leaf stops moving and is prevented from moving until the light beam is released again. Once the photocell is released again, the control opens the gate fully.
- **Photocell type 2:** The light barrier is installed on the outside of the gate system and is active only during closing. If photocell type 2 is triggered, the control opens the gate immediately without waiting for a release.

The control is equipped with a voltage output **24 V AC/max. 300 mA** for the supply to the photocells and a test output which tests the functionality of the connected photocells before each opening

movement. The power supply terminals for the photocells are protected by an electronic fuse which cuts off the supply in the event of an overload.

- Connect the transmitter power supply to terminals **E2** and **E3** of the control.
- Connect the receiver power supply to terminals **E1** and **E2** of the control.
- Connect the floating normally closed contact of the receiver **type 1** to terminals **J5** and **J9** of the control.
- Connect the floating normally closed contact of the receiver **type 2** to terminals **J6** and **J9** of the control.
- Activate testing in menu **P32**.

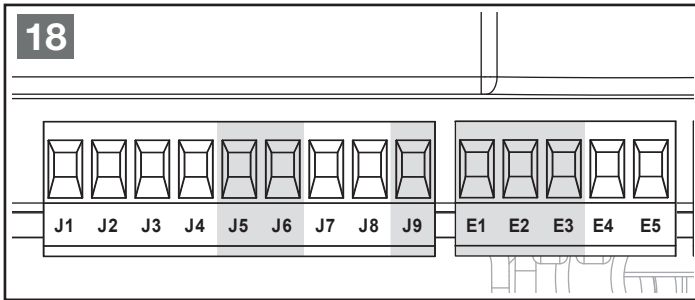

Figure 18 - Connecting the light barriers

#### Note

In the event that multiple pairs of photocells of the same type (type 1/type 2) are installed, their normally closed contacts must be connected in series.

If a reflection light barrier is used, connect the power supply to terminals **E2** and **E3** of the control so that testing can be activated.

### 5.8 Closing edge protection

Two inputs are available for connection of safety contact strips:

#### Safety contact strip type 1 (terminals J7 and J9):

The input is only active in the open direction. In the event that the closing edge protection is actuated during opening, the opener stops and runs for approx. **3 sec.** in the opposite direction. The next start command and/or expiry of the hold-open time (with automatic gate closing activated) closes the gate.

#### Safety contact strip type 2 (terminals J8 and J9):

The input is only active in close direction. In the event that the closing edge protection is actuated during closing, the opener stops and runs for approx. **3 sec.** in the open direction, with automatic gate closing activated, the gate opens fully. In the event that the closing edge protection is actuated 5x in a row with automatic gate closing set, the gate remains open and closes only when a new start command is given.

#### Note

The evaluation function can be selected in menu **P35**.

The following settings are possible:

- Evaluation for 8k2 safety contact strips
- Evaluation for external evaluation devices with normally closed contact and testing
- Evaluation for external evaluation devices with normally closed contact without testing

- Connect the 8k2 edge protection fuse or floating normally closed contact of the safety strip evaluation device **type 1** to terminals **J7** and **J9** of the control.

- Connect the 8k2 edge protection fuse or floating normally closed contact of the safety strip evaluation device **type 2** to terminals **J8** and **J9** of the control.
- Connect the power supply **24 V DC** of an external evaluation device to terminals **E2** and **E3** of the control, this briefly switches off the voltage as a test.. If evaluation is used that cannot be tested in this way, connect the power supply **24 V DC** to terminals **E1** and **E2**.

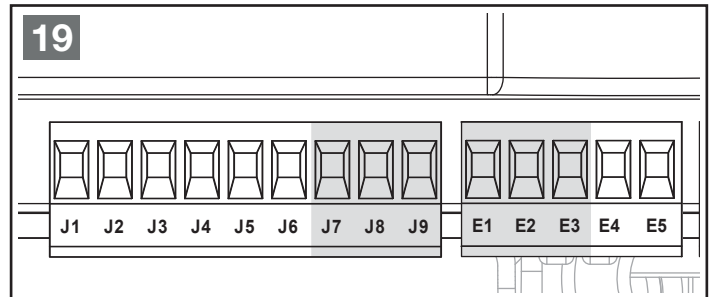

Figure 19 - Connecting the closing edge protection

#### Note

Closing edge protection fuses and associated evaluation devices must satisfy **DIN EN 12978**.

### 5.9 Radio receiver

A receiver with 4-pin stud terminal (e.g. BDE221) may be clipped onto the supplied adapter.

#### Note

Switch of the mains supply before connecting the radio receiver! To program the radio kit, read the manual for the receiver and handheld transmitter.

#### Adapter assignment:

20	0 V DC
21	Channel 1 (start)
5	+ 12 V DC
23	Channel 2 (start P)

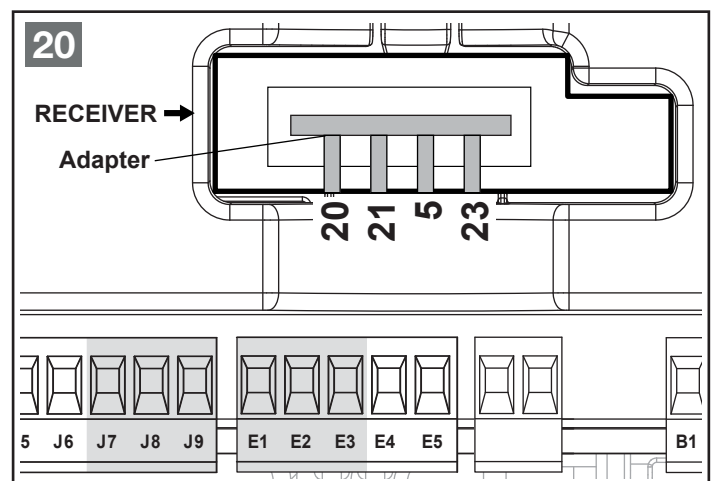

Figure 20 - Connecting the radio

## 6 STRUCTURE OF THE CONTROL

### 6.1 Display indicators

Once the mains supply has been switched on, the control checks the functionality of the display by switching all segments to **8.8.8.8** for approx. **1.5 sec.**

The software version is then displayed.

At the end of the test, the control menu is displayed:

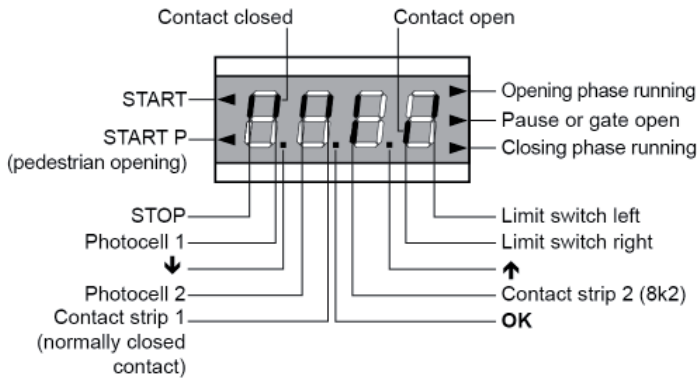

Figure 21 - Display indicators

Figure 21 shows that the inputs of the limit switches, photocell 1, photocell 2, safety strip 1 (in this example, evaluation of the normally closed contact), safety strip 2 (in this example 8k2) and STOP are properly connected.

The display shows the status of all connected command and safety elements as well as the programming buttons.

- Contact closed: the **upper** vertical segment lights up.
- Contact open: the **lower** vertical segment lights up.

The points between the digits indicate the status of the programming buttons. If a button is pressed, the corresponding point lights up.

The arrows on the left of the display indicate the status of the command devices (start and start P) connected to the control. In the event of a start of start P command, the corresponding arrow lights up.

The arrows on the right of the display indicate the status of the gate:

- The upper arrow lights up when the gate is in the opening phase. When flashing, the arrow indicates that the opening phase was started by a safety device (safety strip or light barrier).
- The central arrow indicates that the gate is open or in an intermediate position. When flashing, the arrow indicates that automatic gate closing is activated.
- The lower arrow lights up when the gate is in the closing phase. When flashing, the arrow indicates that the closing phase was started by a safety device (safety strip or light barrier).

### 6.2 The ↑ and ↓ function buttons in normal mode

- The ↓ button corresponds to command contact **START P** (pedestrian opening).
- The ↑ button corresponds to command contact **START** (key switch, push button).

### 6.3 Buttons in programming mode and menu structure

To open or navigate to programming mode, the ↑, ↓ and OK buttons may be used.

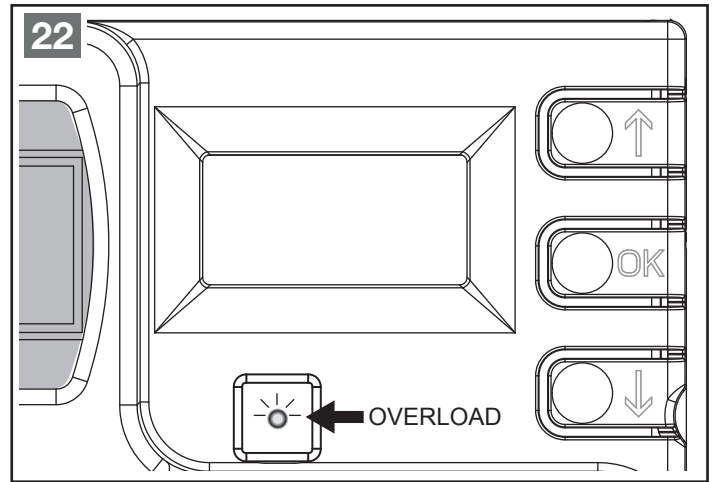

Figure 22 - Programming buttons

The control has **5 main menus**:

1	-PrG	Programming mode
2	-Cnt	Counter value/maintenance counter
3	-Err	Error memory
4	-Lrn	Teach-in mode, teach-in of run times
5	-dEF	Load the factory settings

- Pressing the **OK** buttons opens the selection mode of the main menu. Press and hold the button until the desired main menu, e.g. **-PrG**, appears. Now release the **OK** button.
- In programming mode, the **OK** button is used to confirm changes made.
- Briefly pressing the ↓ button allows you to scroll down in stages. Holding the button in fast forwards down until **EndE** is reached.
- Briefly pressing the ↑ button allows you to scroll up in stages. Holding the button in fast forwards up until **P03** is reached.

### 6.4 Programming mode (main menu 1)

Activating programming mode:

- **Press and hold OK** until **-PrG** appears on the display.
- Release the **OK** button.
- Search for the desired menu with ↑ and ↓ (**P03** to **P46**). (See from **Page 18** for menus).
- Press the **OK** button to display the active setting for the selected menu item. This may be changed with ↑ or ↓.
- **Press OK** again to **save** the change and return to menu selection.

**Exiting programming mode** after making the desired changes:

- **Select EndE** by pressing ↑ or ↓.
- **Press OK**, **nEin** is displayed.
- **Select JA** by pressing ↑ or ↓.
- **Confirm the selection with OK**. This exits programming mode, the changes are saved.

**The control switches back to normal mode (operating mode).**



**Note**

If no action is performed for more than 1 minute, the control exits programming mode without saving the changes. In addition, changes are not saved if programming mode is not exited with **EndE** and **JA**.

Programming mode features three menu types:

- Function menu
- Time menu
- Value menu (service menu)

**6.5 Settings in the function menu**

The function menu allows certain functions to be activated and deactivated, e.g. the light barrier, the stop circuit, etc.

**6.6 Settings in the time menu**

The time menu allows operating times to be set, e.g. the opening and closing time of the motor, the hold-open time, the pre-warning time, etc.

The display mode is dependent on the set value:

- Indicator: Times under 1 minute.



Each press of the **↑** button increases the set time by half a second; each press of the **↓** button reduces the value by half a second.

- Indicator: Times between 1 and 10 minutes.



Each press of the **↑** button increases the set time by 5 seconds; each press of the **↓** button reduces the value by 5 seconds.

- Indicator: Times over 10 minutes.



Each press of the **↑** button increases the set time by half a minute; each press of the **↓** button reduces the value by half a minute.

- If the **↑** or **↓** button is pressed and held, the display fast forwards until the maximum or minimum value of the setting range is reached. In some cases, the value "0" is equivalent to deactivation of the function, as such, "**AUS**" is displayed instead of "0" in this case.

**6.7 Settings in the value menu**

The value menu allows values such as force level, obstacle sensor and maintenance counter to be set.

- Each press of the **↑** button increases the set value; each press of the **↓** button reduces the value.
- If the **↑** or **↓** button is pressed and held, the display fast forwards until the maximum or minimum value of the setting range is reached. In some cases, the value "0" is equivalent to deactivation of the function, as such, "**AUS**" is displayed instead of "0" in this case.

**6.8 Loading the standard values (main menu 5)**

This options resets all menu items back to their default values.

To load the standard values, proceed as follows:

- Press and hold the **OK** button until **-dEF** appears on the display.
  - Release the **OK** button.
  - **ESC** is displayed, press the **↑** or **↓** button to select **dEF**.
  - Confirm the selection with the **OK** button.
  - **nEin** is displayed, press the **↑** or **↓** button to select **JA**.
  - Confirm the selection with the **OK** button.
- The standard values are now set and the control switches to normal mode.

**Note**

See table *"-PrG" menu function overview* on page 34 for the standard values. The standard values are provided for rapid commissioning, they are **not** always suitable as operating values!

**6.9 Starting the self teach-in function for the run times (main menu 4)****WARNING!****Falling out**

Overrunning the limit switches can cause the gate to fall out.

- Start the teach-in process only once it has been confirmed that the limit switches have been set correctly and have been detected!

**Note**

Load the standard values, see *"Loading the standard values (main menu 5)"* on page 17.

Set the direction logic in menu **P10**.

The procedure for teaching in the operating times may only be started when the command inputs are operated in standard mode (menu **P28 = StAn**).

**Connect the safety devices** only **after** teaching in the operating times and activate in menus **P29**, **P30**, **P31**, **P33** and **P34**.

Open the gate approx. 1 m **before** teaching in the operating times!

This function allows the control to determine the optimum operating times (run times) of the connected motor.

To activate the self teach-in function, proceed as follows:

- Press and hold the **OK** button until **-Lrn** appears on the display.
- Release the **OK** button.
- **nEin** is displayed, press the **↑** or **↓** button to select **JA**.
- Confirm the selection with the **OK** button and start the self teach-in function.
- Start the teach-in process, the motor moves first in the close direction until the gate closed limit switch is reached.

- The leaf opens until the gate open limit switch is reached.
- The leaf closes until the gate closed end position is reached.
- The maximum required current value (obstacle sensor) for the open direction (**P39.o**) appears on the display. Change with **↑** / **↓** if necessary. Press the **OK** button to save, **P39.o** appears on the display.

**Note**

If **no** operation is performed within 20 sec., the control exits programming mode **without** saving the changes.

- Press the **↓** button, **P39.c** appears on the display.
- Press the **OK** button, the maximum required current value (obstacle sensor) for the close direction (**P39.c**) appears on the display. Change with **↑** / **↓** if necessary. Press the **OK** button to save, **P39.c** appears on the display.
- Press and hold **↓** until **Ende** appears.
- Press the **OK** button and select **JA**.
- Confirm with the **OK** button to switch from programming mode to normal mode.

**Note**

The obstacle sensor values are **not** applied if the menu is not exited as described above!

- The operating values are now taught in.

After completing the teach-in procedure and saving the current values (obstacle sensor), the control switches back to normal mode.

**Note**

The teach-in procedure is performed at minimum speed!

## 7 CONFIGURING THE CONTROL

### 7.1 The configuration menu

The individual options of the configuration menu are explained on the following pages. After teaching in the operating times, the changes required by the gate system may be made and saved. **IMPORTANT:** Always exit the configuration menu using menu item **EndE**, otherwise the changes are not saved.

Activating programming mode:

- **Press and hold OK** until **PrG** appears on the display.
- Release the **OK** button.
- Search for the desired menu with **↑** and **↓** (**P03** to **P46**).
- Press the **OK** button to display the active setting for the selected menu item. This may be changed with **↑** or **↓**.
- **Press OK** again to **save** the change and return to menu selection.

**Exiting programming mode** after making the desired changes:

- **Select EndE** by pressing **↑** or **↓**.
- **Press OK**, **nEin** is displayed.
- **Select JA** by pressing **↑** or **↓**.
- Confirm the selection with **OK**. This exits programming mode, the changes are saved. The control switches back to normal mode (operating mode).

**Note**

Make changes one at a time and **check that they are correct**. This helps to identify errors immediately so that they can be rectified promptly without having to undertake time-consuming troubleshooting measures.

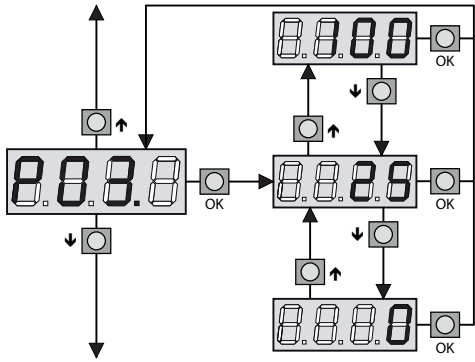

### 7.2 Gate partially open position (pedestrian access)

This menu allows you to set the value for the partially open position. If the **START P** command (pedestrian opening) is activated, the motor opens as far as the partially open position. Setting range: 0 - 100% of complete opening.

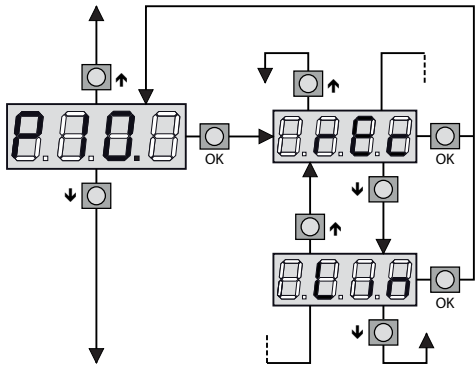

### 7.3 Opening direction of the gate

This menu allows you to set the opening direction of the gate.

The following settings are possible:

- rEc** The gate opens to the right
- LIn** The gate opens to the left

#### Note

The opening direction is determined from the inside of the gate system.

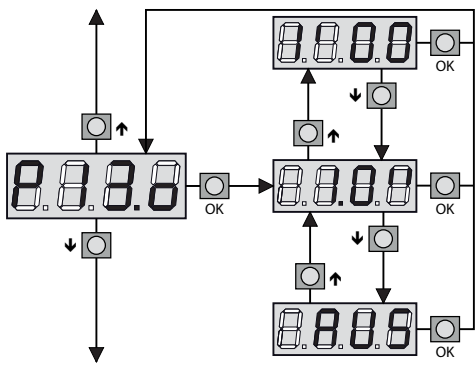

### 7.4 Pre-warning period warning light (terminals E4/E5) in the open direction

This menu allows you to set the pre-warning time of the warning light in the open direction. As such, the warning light lights up not only when the gate is moving but also for the set time before each gate movement in the open direction.

#### Note

Select "AUS" if no warning light is connected.

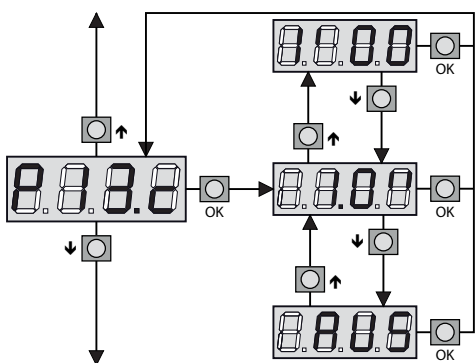

### 7.5 Pre-warning period warning light (terminals E4/E5) in the close direction

This menu allows you to set the pre-warning time of the warning light in the close direction. As such, the warning light lights up not only when the gate is moving but also for the set time before each gate movement in the close direction.

#### Note

Select "AUS" if no warning light is connected.

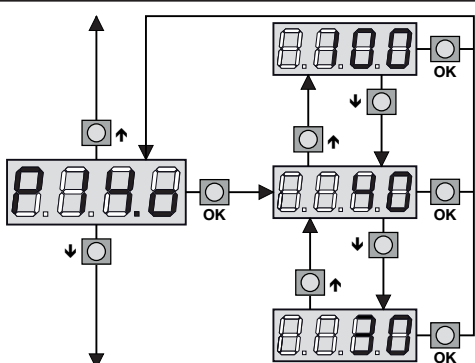

### 7.6 Running speed in the open direction

This menu allows you to set the running speed in the open direction. The value displayed represents the gate running speed in %.

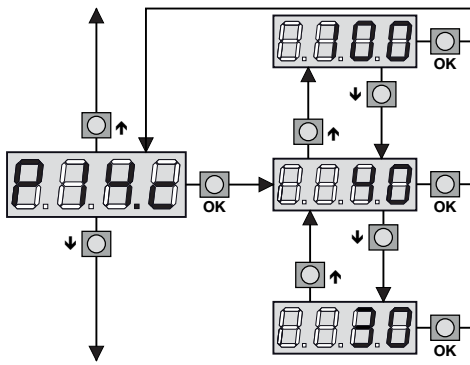

**7.7 Running speed in the close direction**

This menu allows you to set the running speed in the close direction. The value displayed represents the gate running speed in %.

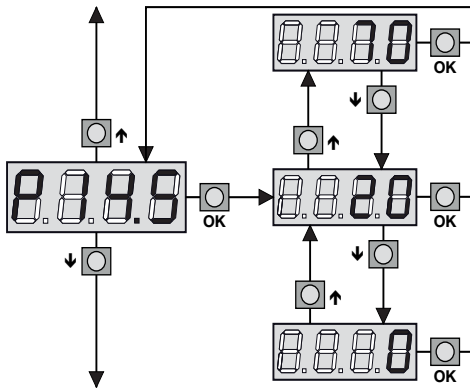

**7.8 Soft running speed**

This menu allows you to set the soft running speed. The value displayed represents the gate speed in %.

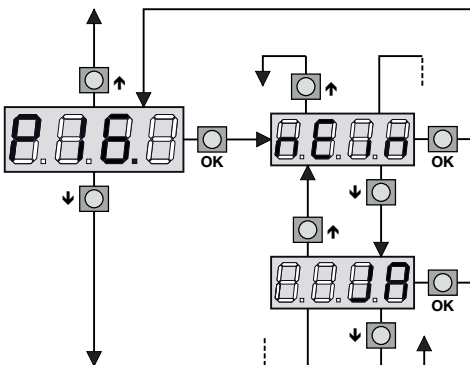

**7.9 Start-up suppression**

This menu allows you to activate start-up suppression. With start-up suppression activated, the values set in menus **P14.o** or **P14.c** are ignored during the first 2 seconds of the start phase, and the motor is run at maximum power.

- nEin** Function is deactivated.
- JA** Function is activated.

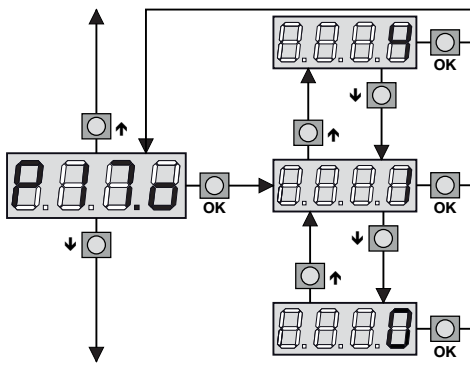

**7.10 Warm-up ramp in the open direction**

This menu allows you to set the length of the warm-up ramp in the open direction, in order not to unnecessarily burden the motor. With this function, the power of the motor is slowly increased during the start phase, according to the set value, until the value in menu **P14.o** is reached. The higher the value, the longer it takes for the motor to reach nominal power.

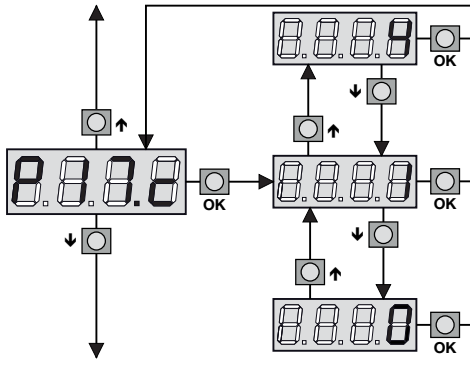

**7.11 Warm-up ramp in the close direction**

This menu allows you to set the length of the warm-up ramp in the close direction, in order not to unnecessarily burden the motor. With this function, the power of the motor is slowly increased during the start phase, according to the set value, until the value in menu **P14.c** is reached. The higher the value, the longer it takes for the motor to reach nominal power.

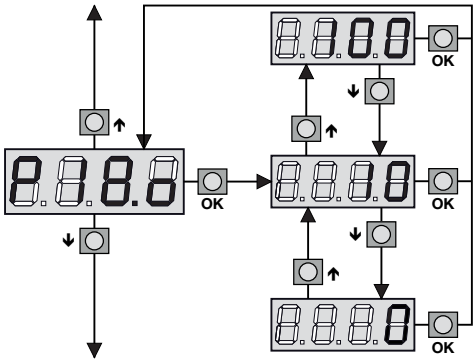

### 7.12 Soft stop in the open direction

This menu allows you to set the length of the soft stop phase in the open direction. With this function, the motor is operated at minimum speed for the set length before reaching the **Open** end position.

The length can be set between **0 and 100%** of the total travel path.

#### Note

The soft stop phase cannot be completely deactivated. Soft stop is initiated over the final 300 mm, irrespective of the set value.

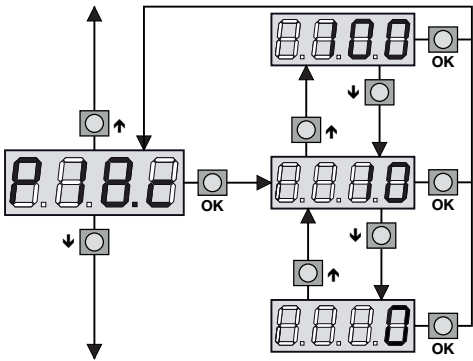

### 7.13 Soft stop in the close direction

This menu allows you to set the length of the soft stop phase in the close direction. With this function, the motor is operated at minimum speed for the set length before reaching the **Closed** end position.

The length can be set between **0 and 100%** of the total travel path.

#### Note

The soft stop phase cannot be completely deactivated. Soft stop is initiated over the final 300 mm, irrespective of the set value.

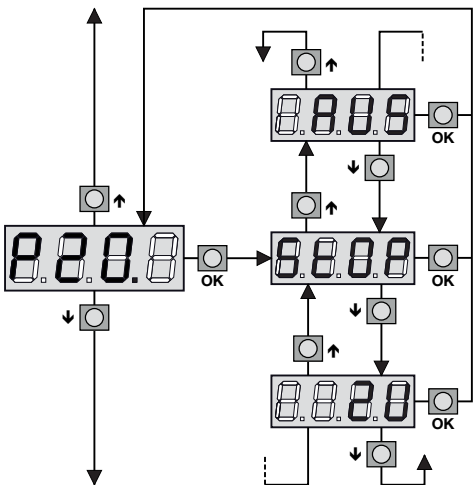

### 7.14 Start pulse (terminals J1/J4) when the gate is opening

This menu configures the behaviour of the control during the opening phase following a command input.

**StoP** The gate stops.

**ZU** The gate stops and closes again immediately.

**AUS** The gate continues the opening phase (the command is ignored).

#### Note

With pulse operation, select the **StoP** function.

With automatic operation (open via start command and close via automatic gate closing), select the **AUS** function.

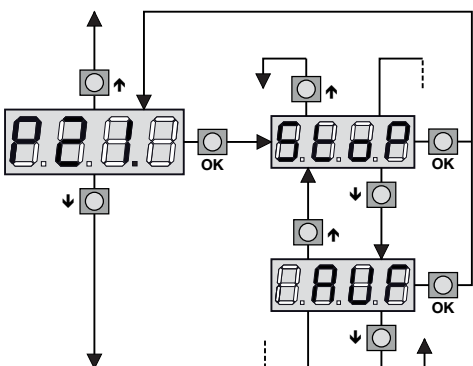

### 7.15 Start pulse (terminals J1/J4) when the gate is closing

This menu configures the behaviour of the control during the closing phase following a command input.

**StoP** The gate stops.

**AUF** The gate stops and opens again immediately.

#### Note

With pulse operation, select the **StoP** function.

With automatic operation (open via start command and close via automatic gate closing), select the **AUS** function.

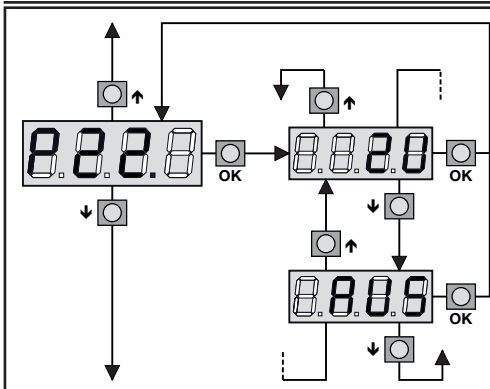

**7.16 Start pulse (terminals J1/J4) when the gate is opening**

This menu configures the behaviour of the control during the opening phase following a command input.

- ZU** The gate closes again.
- AUS** The gate remains open (the command is ignored).
- PAUS** The gate remains open, the hold-open time is restarted.

**Note**

With pulse operation, select the **ZU** function. With automatic operation (open via start command and close via automatic gate closing), select the **AUS** or **PAUS** function.

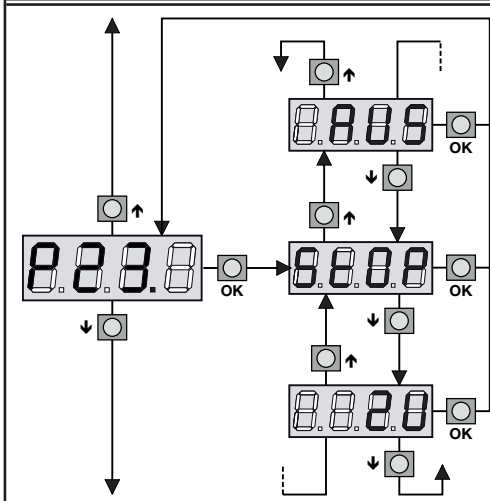

**7.17 Start pulse (START P, terminals J2/J4) with pedestrian opening**

This menu configures the behaviour of the control with pedestrian opening following a command input (START P/pedestrian).

- StoP** The gate stops.
- ZU** The gate stops and closes again immediately.
- AUS** The gate continues the opening phase (the command is ignored).

**Note**

In the event that a **START** command is given during pedestrian opening, the leaf opens fully. The **START P** command (pedestrian) is ignored if a **START** command to start or stop the gate was given beforehand.

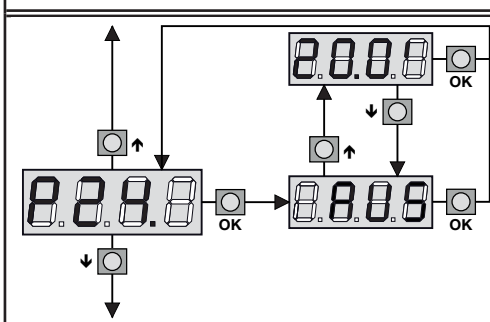

**7.18 Automatic closing**

This menu allows you to set the hold-open time. Once the set time has expired, the gate closes automatically. The gate can also be closed before the hold-open time expires by giving a new **START** command. If the "**AUS**" or "**PAUS**" option has been selected in menu **P22**, the gate closes only via the automatic closing function.

**Note**

If a **stop** command is given, the control switches to semi-automatic mode. This deactivates the automatic closing function. Automatic mode is activated only following a new **START** command.

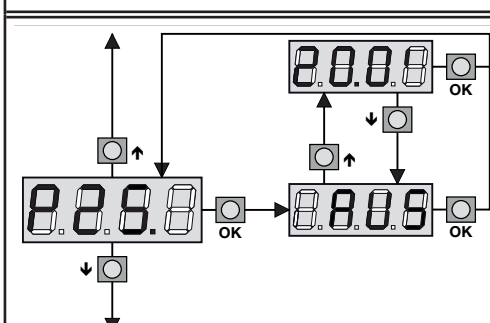

**7.19 Quick close after passage**

This option allows the hold-open time to be cancelled and the closing procedure to begin earlier. Once the light barrier has been passed and following expiry of the set time, the gate is closed immediately. The time must always be less than the time set in menu **P24**.

**Note**

This function is only possible if automatic gate closing is activated. This function is deactivated in semi-automatic mode.

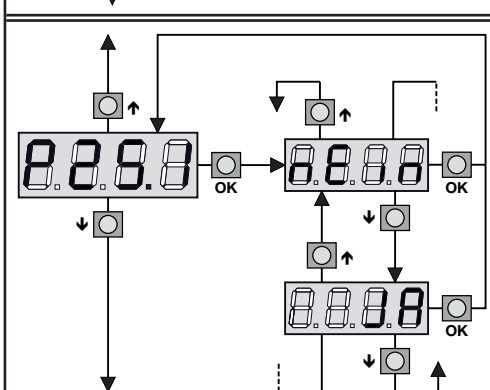

**7.20 Quick close after passage of both light barriers**

This option allows the hold-open time to be cancelled and the closing procedure to begin earlier. Once both light barriers (type 1 and type 2) have been passed and following expiry of the time set in menu **P25**, the gate is closed immediately.

- nEin** Function is deactivated.
- JA** Function is activated.

**Note**

This function is only possible if automatic gate closing is activated. This function is deactivated in semi-automatic mode.

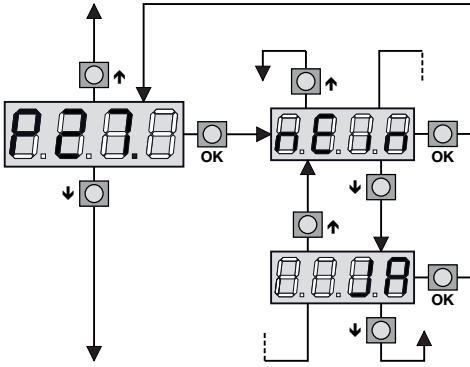

### 7.21 Warning light (terminals E4/E5) during the pause time

The warning light is usually actuated only when the gate is moving. If this function is activated, the warning light also lights up when the gate is open or in an intermediate position.

#### Note

This function is only possible if automatic gate closing is activated.  
This function is deactivated in semi-automatic mode.

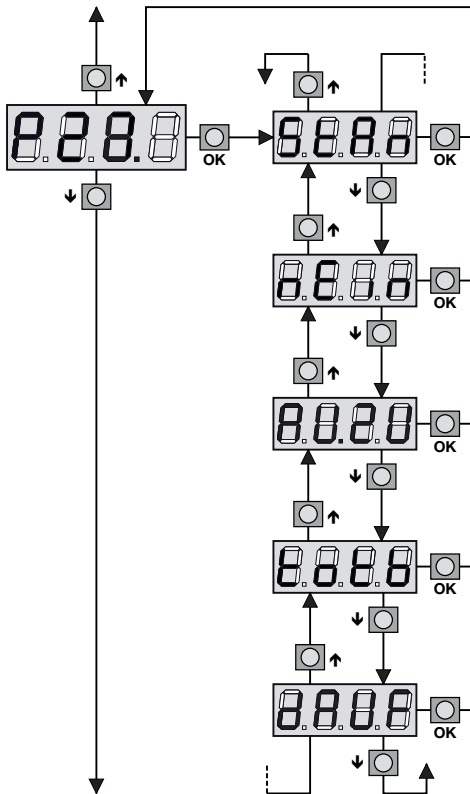

### 7.22 Command inputs (terminals J1/J4, J2/J4) function

This menu allows you to assign different functions to the command inputs START and START P.

**StAn** Standard function of command inputs **START** and **START P**.

**nEin** The control's command inputs are deactivated.  
The radio receiver's inputs are active.

**AU.ZU** The **START** input opens the gate.  
The **START P** input closes the gate.

**totb** totb function = person present: The gate opens if the **START** input is actuated and closes if the **START P** input is actuated.

**dAUF** Timer function: The gate opens and remains open until the continuous open command at the **START** or **START P** input is opened.  
The gate closes again once the hold-open and pre-warning times have expired.

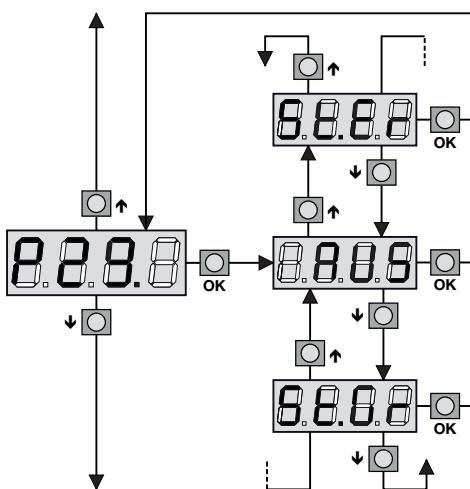

### 7.23 Stop input (terminals J3/J4)

This menu allows you to specify the functions of the stop input.

**AUS** The STOP input is deactivated.

**St.Gr** A STOP command stops gate movement. With the next START command, the gate moves in the same direction.

**St.Er** A STOP command stops gate movement. With the next START command, the gate moves in the opposite direction.

#### Note

The parameters set here also determine the behaviour following a **START** command following switch-off by an obstacle sensor or the closing edge protection. If the function is deactivated, the gate moves in the same direction following a **START** command.

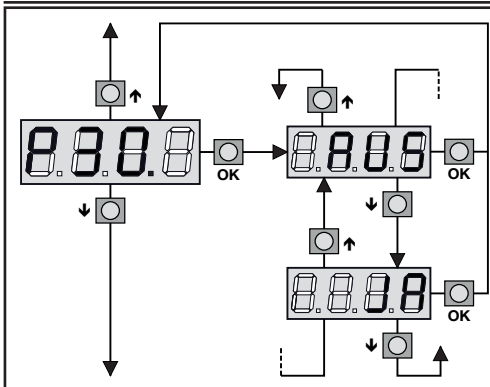

**7.24 Photocell 1 input (terminals J5/J9)**

This menu allows you to activate light barrier type 1. This light barrier is active on opening and closing, a gate movement is stopped immediately and prevented until the light barrier is released.

The light barrier is installed inside the gate.

- nEin** The input is deactivated.  
Input bridging is not necessary.
- JA** The input is activated.

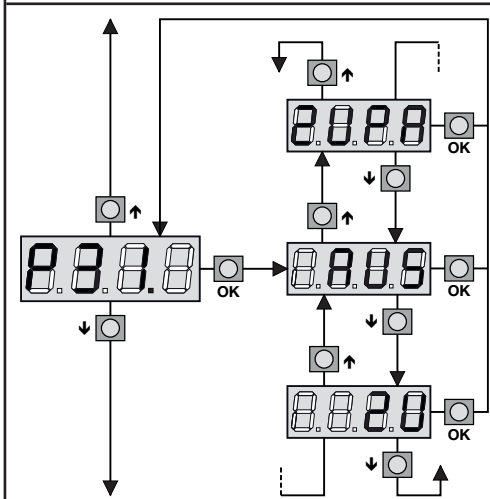

**7.25 Photocell 2 input (terminals J6/J9)**

This menu allows you to activate light barrier type 2. This light barrier is active on closing and when the gate is stationary and is installed in front of the gate (outside).

- AUS** The input is deactivated.  
Input bridging is not necessary.
- ZUPA** The input is active on closing; gate closing is stopped immediately if the light barrier is passed and the gate is opened again. In addition, the light barrier is also active when the gate is stationary, i.e. if the light barrier is passed when the gate is stationary, the gate cannot be opened or closed.
- ZU** The input is only active on closing.

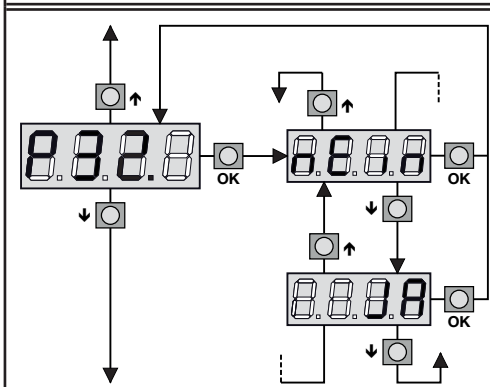

**7.26 Testing the safety devices**

This menu allows you to activate testing of the connected safety devices. When this option is activated, the function test is performed before each gate cycle. In the event that a malfunction is detected, no gate movement takes place and the warning light lights up for 5 sec.

- nEin** Function is deactivated.
- JA** Testing is activated for light barriers.

**Note**  
Activate light barrier testing to increase safety.

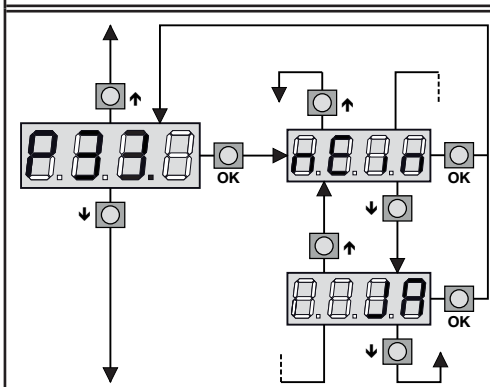

**7.27 Closing edge protection 1 (terminals J7/J9) input**

This menu allows you to activate the closing edge protection type 1 input. The input is only active in the open direction.

- nEin** The input is deactivated.  
Input bridging is not necessary.
- JA** The input is activated.



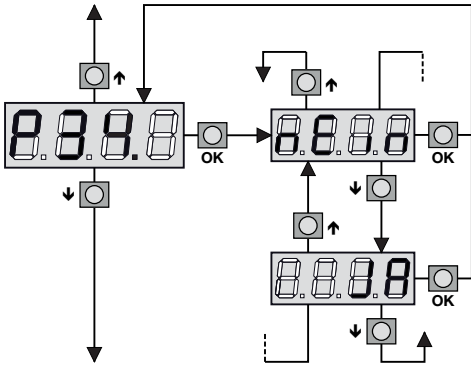

### 7.28 Closing edge protection 2 (terminals J8/J9) input

This menu allows you to activate the closing edge protection type 2 input. The input is only active in close direction.

- nEin** The input is deactivated.  
Input bridging is not necessary.
- JA** The input is activated.

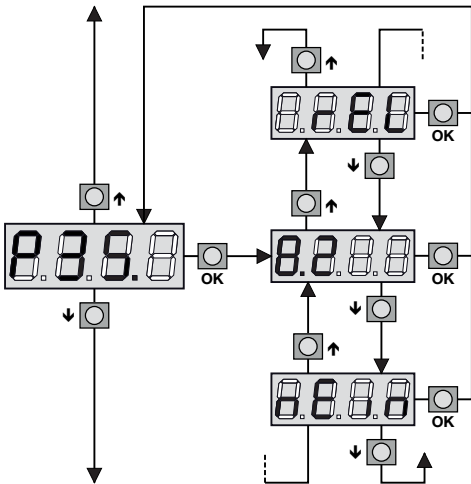

### 7.29 Evaluation of the closing edge protection

This menu allows you to set evaluation of the closing edge protection.

- nEin** External evaluation with relay output (normally closed contact) without testing
- 8.2** The integrated 8k2 evaluation is activated.
- rEL** External evaluation with relay output (normally closed contact) with testing

#### Note

**nEin** Set if no closing edge protection is connected.

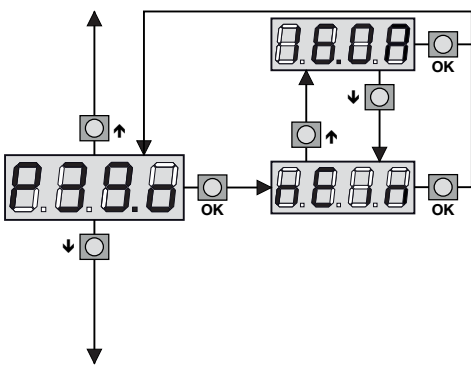

### 7.30 Obstacle sensor in the open direction

This menu allows you to set the sensitivity of the obstacle sensor (current monitoring) for the open direction.

- If the value "nEin" is selected, the obstacle sensor is deactivated.
- The higher the value, the more sensitive the control's response to an obstacle.

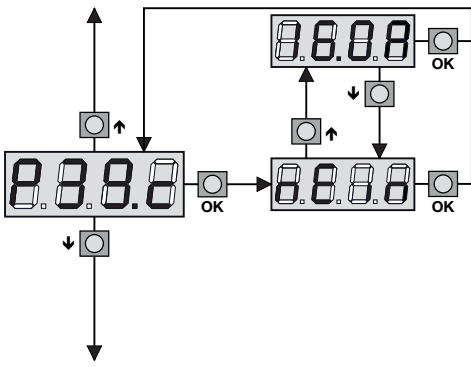

### 7.31 Obstacle sensor in the close direction

This menu allows you to set the sensitivity of the obstacle sensor (current monitoring) for the close direction.

- If the value "nEin" is selected, the obstacle sensor is deactivated.
- The higher the value, the more sensitive the control's response to an obstacle.

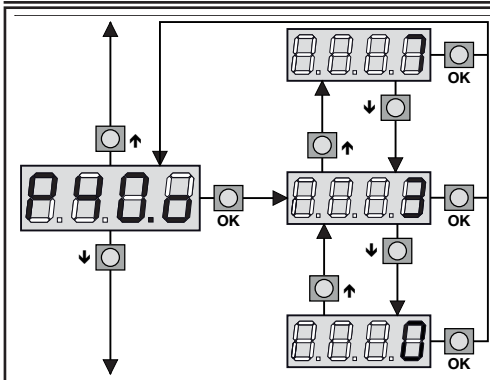

**7.32 Obstacle sensor in the open direction**

This menu allows you to set the sensitivity of the obstacle sensor (speed monitoring) for the open direction.

- If the value "0" is selected, the obstacle sensor is deactivated.
- The higher the value, the more sensitive the control's response to an obstacle.

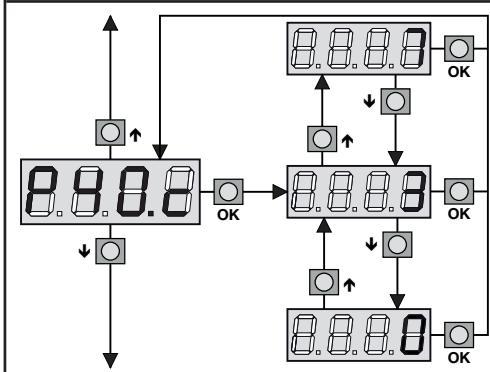

**7.33 Obstacle sensor in the close direction**

This menu allows you to set the sensitivity of the obstacle sensor (speed monitoring) for the close direction.

- If the value "0" is selected, the obstacle sensor is deactivated.
- The higher the value, the more sensitive the control's response to an obstacle.

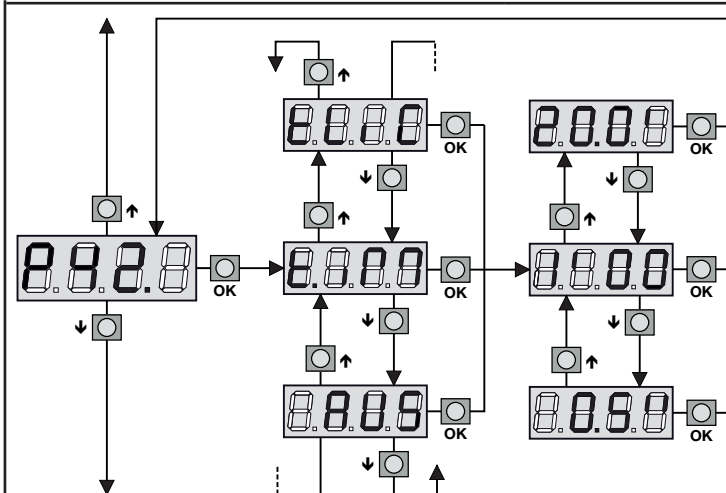

**7.34 Function of the option relay (terminals B1/B2)**

This menu allows you to set the function of the option relay. See also **"Connecting external lighting" on page 14**.

- t.iM** The relay is actuated for the set time following a **Start** or **Start P** command.
- AUS** The function is deactivated.
- t.Lic** The relay is actuated when the gate is moving. After reaching the end position or intermediate position, the timer starts for the set time and switches the relay off upon expiry of the time.

**Note**

If **JA** is set in menu **P27** (see **Page 23**), the relay remains on during the pause time.  
If a warning light (e.g. warning beacon) is operated, set the time value to "0".

- SL** Signal lights function (for function see menu **P44**).

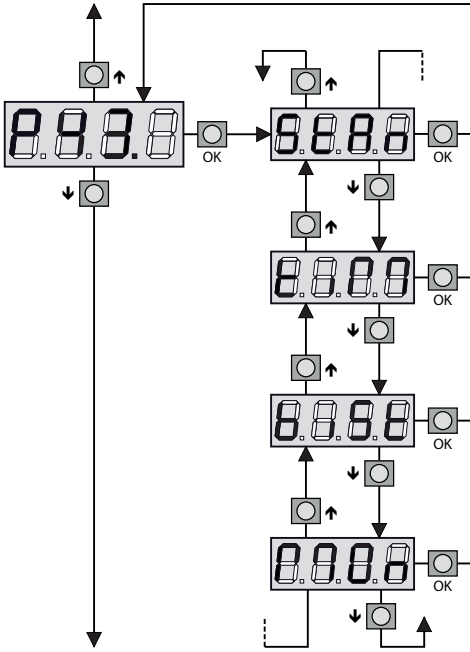

### 7.35 Radio receiver channel 2 function

This menu allows you to set the function that is executed in the event of a command input via channel 2 of the radio receiver.

- StAn** Standard function, on command input the pedestrian opening function is executed.
- tiM** Timer function, the option relay (terminals **B1/B2**) switches on for the time set in menu **P42**.
- biSt** Bistable function, the option relay (terminals **B1/B2**) switches the switching status (**ON/OFF** function) following every command input.
- Mon** Monostable function, the option relay (terminals **B1/B2**) is actuated during the command input and switches off again when the handheld transmitter button is released.

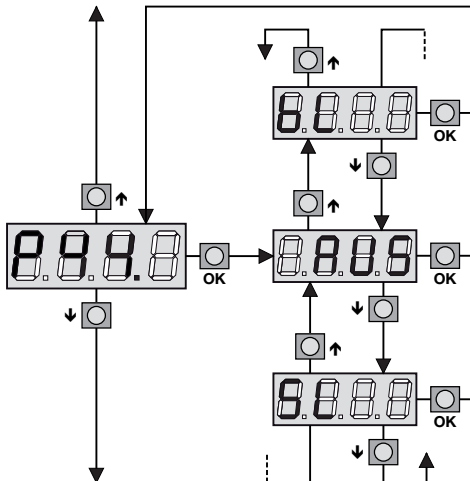

### 7.36 Warning/signal light output function

This menu allows you to set the function of the flashing/signal light output.

- AUS** The function is deactivated.
- bL** Flashing function, the connected light flashes when the gate is moving.
- SL** Signal lights function, the connected signal light uses different states to indicate the status of the gate:
- Gate in opening phase, slow flashing (2 Hz)
  - Gate in closing phase, fast flashing (4 Hz)
  - Gate closed or in intermediate position, light on
  - Gate open, light off

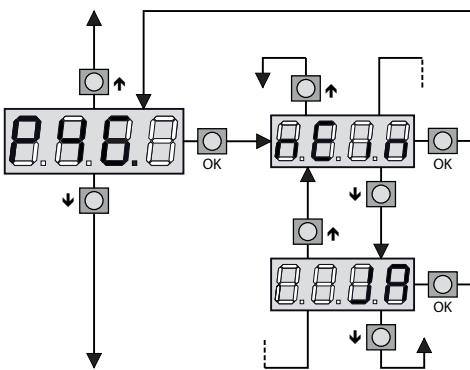

### 7.37 ADI interface

This menu allows you to activate the ADI interface.

- nEin** The interface is deactivated.
- JA** The interface is activated.

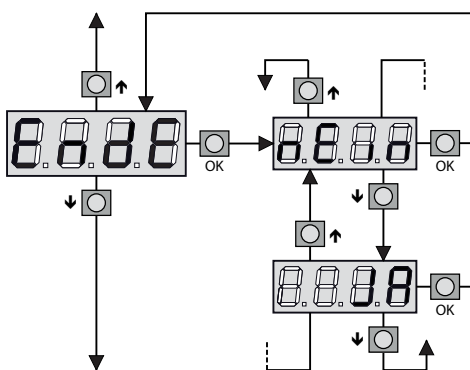

### 7.38 End of programming

This menu allows you to exit programming mode and save all changes.

- nEin** Additional changes can be made, the control does not exit programming mode.
- JA** The changes are saved, the control exits programming mode.

**THE CHANGES ARE SAVED;  
THE CONTROL IS OPERATIONAL.**

### 7.39 Reading the cycle counter

The control is equipped with an integrated counter, which stores completed opening cycles. A maintenance counter is also integrated, which indicates that maintenance is required once the set value is reached.

The counters differ as follows:

- The cycle counter **tot** cannot be reset.
- The maintenance counter **MA**n indicates the cycles remaining until maintenance is due and can be switched off early or reset to the desired maintenance interval.

The diagram shown indicates reading off the existing cycles, the cycles remaining until maintenance is due and setting the new maintenance interval. In the example, the control has executed 12451 cycles and there are 1322 cycles remaining until maintenance is due.

**Area 1** indicates the counter status of executed cycles. Pressing the **↑** or **↓** button displays the thousand or hundred scale.

**Area 2** indicates the remaining cycles until maintenance is due. The actual value is rounded to the nearest hundred.

**Area 3** is for entry of the number of cycles you wish to be executed before maintenance is due. Pressing the **↑** or **↓** button rounds the indicated value to the nearest thousand or hundred, each additional press increases or decreases the value by 1000 units. This clears the maintenance interval.

### 7.40 Indicating maintenance due

If the set number of cycles is exceeded, the warning light indicates that maintenance of the gate system is required. In this case, the warning light is switched on for **5 sec.** before each opening cycle.

**Note**

Maintenance and repair work may only be carried out by expert personnel.

Indication of maintenance due (signalisation by the warning light) is terminated only when a new maintenance interval is entered or the previous interval is cleared. If the counter is set to "0", the maintenance counter is deactivated.

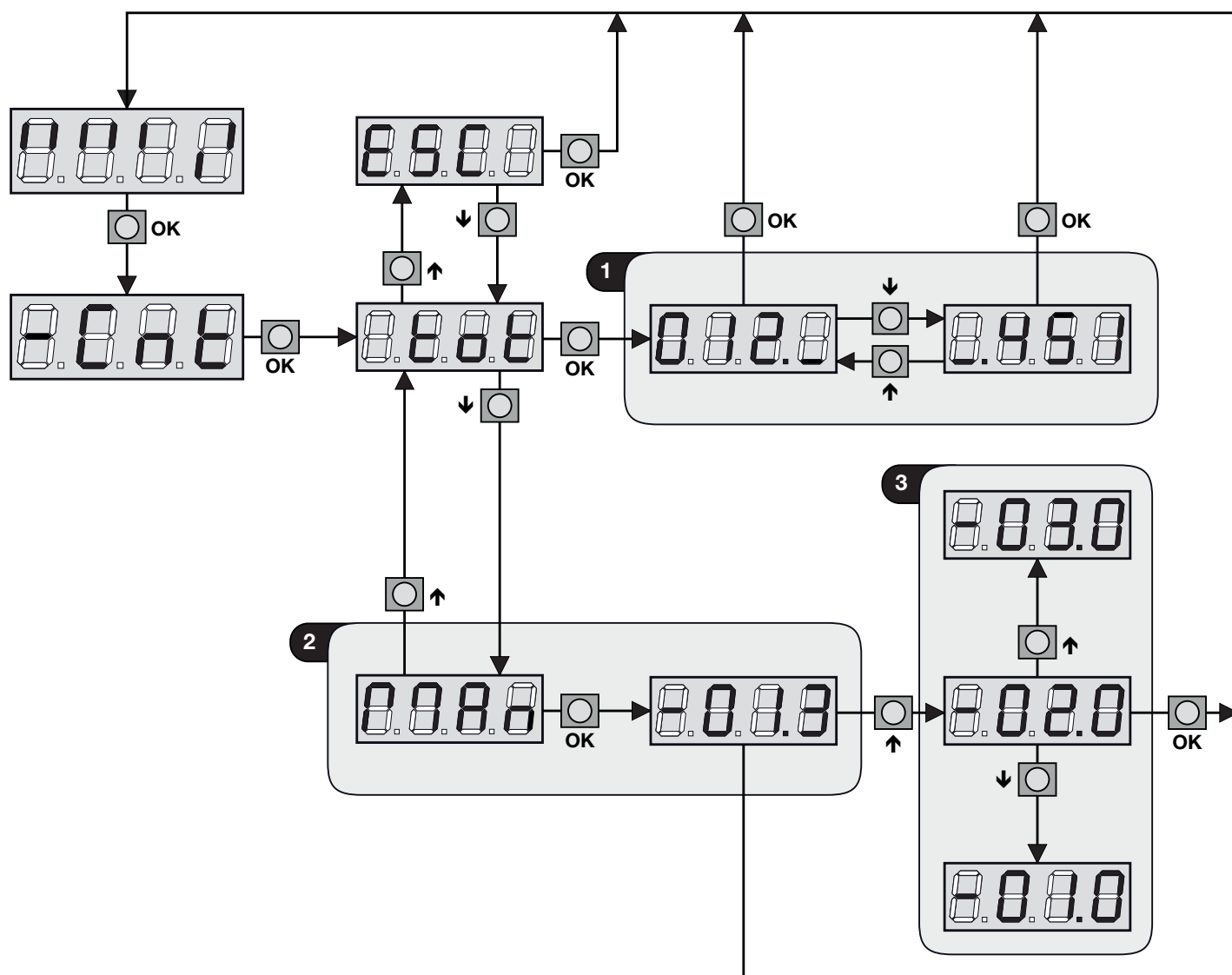

## 8 OPERATION

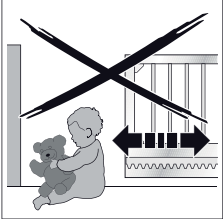
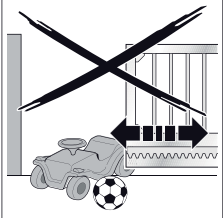
	<h1>WARNING!</h1>
	<p><b>Risk of injury when the gate is moving!</b> A moving gate can give rise to injury or damage in the gate area.</p> <ul style="list-style-type: none"> <li>• Children must not play with the gate system.</li> <li>• Ensure that no persons or objects are located within the movement area of the gate.</li> <li>• Ensure that no persons or objects are located between the gate and opener mechanism.</li> </ul>
	<ul style="list-style-type: none"> <li>• In the event that the gate system is equipped with only one safety device, operate the sliding opener only when you can clearly see the movement area of the gate.</li> <li>• Monitor movement of the gate until it has reached its end position.</li> <li>• Only pass or walk through gate openings of remote-controlled gate systems if the gate is in the gate open end position!</li> </ul>

	<h1>WARNING!</h1>
<b>Danger of crushing and shearing</b>	
When the gate is moving, there is a risk fingers or limbs becoming crushed or severed by the gear rack or between the gate and closing edge.	
<ul style="list-style-type: none"> <li>• Never grab hold of the gear rack, gear wheel or main/secondary closing edges when the gate is moving!</li> </ul>	

### 8.1 Instructing personnel

- Instruct all personnel who use the gate system on how to operate the system properly and safely.
- Demonstrate and test the mechanical release as well as the safety recoil.

### 8.2 Function check

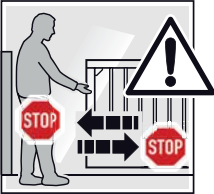
	<ul style="list-style-type: none"> <li>• Test the function of the mechanical release and safety recoil on a <b>monthly</b> basis.</li> <li>• <b>Check the safety recoil:</b> actuate the closing edge protection when the gate is closing and opening. The gate system must start the safety recoil.</li> </ul>
<ul style="list-style-type: none"> <li>• In the event that the safety recoil fails, an expert must be commissioned immediately to check and repair if necessary.</li> </ul>	

### 8.3 Conduct in the event of/following a power failure

	<h1>WARNING!</h1>
<b>Risk of injury from unexpected gate movement</b>	
The power supply to the system must be switched off before each release and locking action. This prevents an unintended pulse from moving the gate.	
<ul style="list-style-type: none"> <li>• When performing work on the gate system, switch off the mains supply and secure it against unauthorised re-activation.</li> </ul>	

In order to open or close the gate by hand in the event of a power failure, it must be released from the opener. See also "**Actuating the emergency release**" on page 11.

#### Note

Slide the gate until shortly ahead of the "gate open" end position and release the opener to allow the next start command to start the reference run following the power failure. The opener then closes at minimum speed until the "gate closed" limit switch is reached.

**Failure to do so can prevent** the gate from opening or closing fully following the power failure.

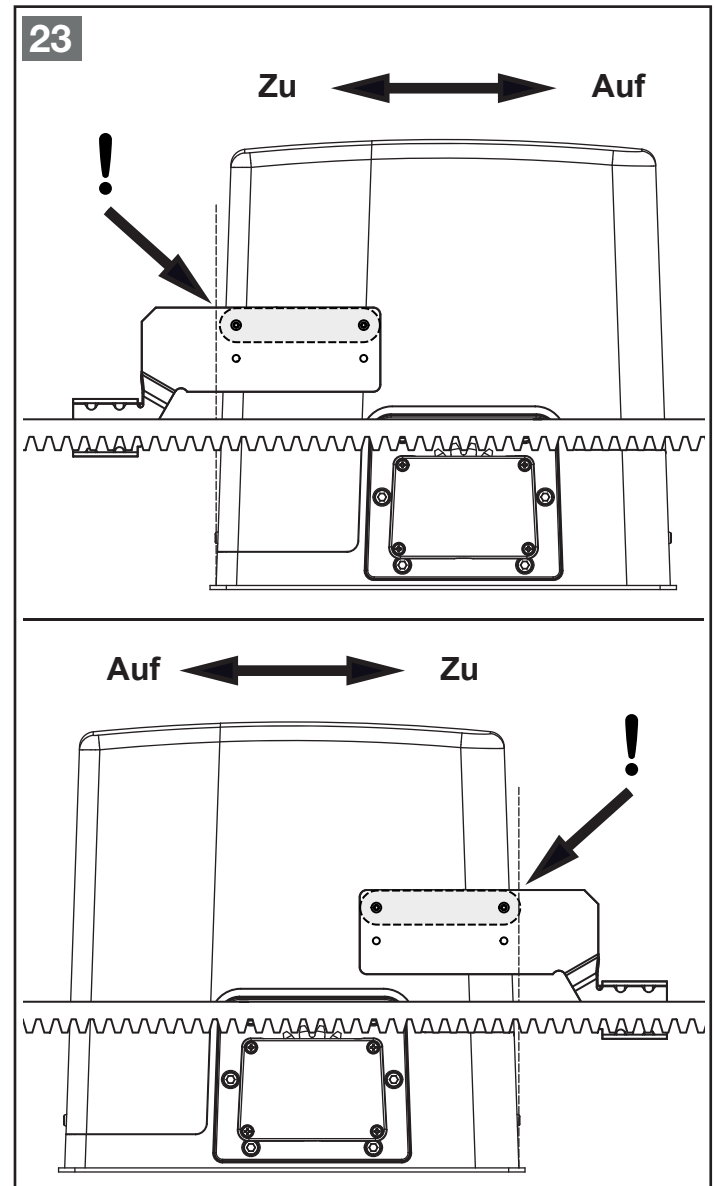

Figure 23 - Releasing the opener in the event of a power failure

## 9 INSPECTION, CHECKS AND MAINTENANCE

The sliding opener does not require maintenance, however the overall gate system requires maintenance. For your own safety, we recommend having the gate system inspected and maintained by an expert in accordance with the manufacturer's information.



### WARNING!

#### Risk of injury from unexpected gate movement

Unintentional switch on of the opener by a third party can give rise to unexpected gate movements when performing inspection and maintenance work.

- Always switch off the mains supply when performing work on the gate system.
- Secure the gate system against unauthorised re-activation.

An inspection or repair may only be performed by an expert. Please contact your supplier in this regard.

The following aspects may be performed on a monthly basis by the operator:

- Visual inspection of the opener housing.
- Check of all safety and protection functions to ensure their flawless operation.
- Function check of the mechanical release to ensure its flawless operation, check to ensure that the gate moves freely.
- ▶ In the event of faults or shortcomings, take the gate system out of operation and have the faults rectified immediately.

The following aspects may only be performed by an expert and must be checked at least every 12 months (recommended every 6 months):

#### Gate and gate mechanism

- Condition, fixing and wear of the gate leaf and gate panel
- Condition and wear of the seals (if present)
- Fixing, wear and lubrication of the rollers, rolling systems and hinges
- Fixing, wear and lubrication of the guide rollers
- Condition, fixing and wear of the mechanical end stops (overrun protection) and mounting (safeguard against lifting out/derailment)
- ▶ In the event of faults or shortcomings, take the gate system out of operation and have the faults rectified immediately.
- ▶ Ensure to observe the inspection and maintenance specifications of the gate manufacturer.

#### Opener and control

- Opener fixing and any brackets that may be present
- Condition of the gear housing and opener cover
- Braking function - actuate the stop circuit, the opener must stop immediately without running on
- Fixing and condition of the gear rack
- Condition of the opener pinion and its anti-trap protection
- Check of the distance between the opener pinion and gear rack over the complete travel path (min. 1 - 2 mm)
- Fixing and condition of the end position magnets
- Function of the limit switches
- Function check of the mechanical release to ensure its flawless operation, check to ensure that the gate moves freely
- Condition of the electrical lines and connections
- Function and condition of the command devices
- Function and condition of the safety contact strips
- Function of the force limitation
- Function and condition of the light barriers
- Function and condition of the emergency command device (emergency stop)
- Function and condition of the warning and signal lights
- ▶ In the event of faults or shortcomings, take the gate system out of operation and have the faults rectified immediately.

#### Note

In workplaces, the closing forces must be verified at least once annually in accordance with Section 10.2 of ASR 1.7 using suitable measurement technology, which, for example, is capable of indicating the temporal force progression at the closing edges.

## 10 MALFUNCTIONS

This section describes malfunctions, their causes and possible rectification measures.

### 10.1 LED MAINS does not switch on

<b>Cause:</b>	There is no voltage at the control.
<b>Action:</b>	<ol style="list-style-type: none"> <li>1. Ensure that there is no power interruption in the mains grid.</li> <li>2. Before performing any intervention in the control, switch off the in-built mains circuit breaker and disconnect the supply line from the control.</li> <li>3. Check whether fuse F1 has blown. If it has, replace with an equivalent fuse (type 250 V, F2,5AL).</li> </ol>

### 10.2 LED OVERLOAD switched on

<b>Cause:</b>	Overload at 24 V voltage output/external consumers.
<b>Action:</b>	<ol style="list-style-type: none"> <li>1. Disconnect plug-in terminals (terminals J1-J9 and E1-E5). The LED goes out.</li> <li>2. Find and rectify the cause of the overload.</li> <li>3. Insert the plug-in terminals again. Check whether or not the LED lights up again.</li> </ol>

### 10.3 Extended pre-warning period

<b>Cause:</b>	The warning light lights up immediately following a start command, however the gate opens only after 5 seconds. This means that the cycle count of the maintenance counter has been exceeded.
<b>Action:</b>	Perform maintenance.

### 10.4 Opener runs at minimum speed in the open and close direction

<b>Cause:</b>	Following a power failure, a reference run must be performed in no limit switch was actuated when the power failed.
<b>Action:</b>	Perform a reference run, i.e. run the opener until the "gate closed" limit switch is reached.

### 10.5 The gate does not open or close fully

<b>Cause:</b>	<ul style="list-style-type: none"> <li>• The opener was released and engaged again at a different position without the mains supply being switched off.</li> <li>• The opener was released on power failure and not locked in the correct open or closed end position.</li> </ul>
<b>Action:</b>	<ol style="list-style-type: none"> <li>1. Switch off the mains supply.</li> <li>2. Release the opener and slide the gate to the intermediate position.</li> <li>3. Lock the opener.</li> <li>4. Switch on the mains supply.</li> <li>5. Give a start command and perform a reference run, i.e. run the opener until the "gate closed" limit switch is reached.</li> </ol>

## 11 LOADING THE ERROR MEMORY (MAIN MENU 3)

This options allows you to call and display the last 30 system errors.

#### Loading the error memory:

- Press and hold **OK** until-**Err** is displayed.
- Release the **OK** button.
- **ESC** is displayed, switch to the error memory (selection 1 - 30) by pressing the **↑** or **↓** button.
- Confirm the selection with the **OK** button, the corresponding error code is displayed.
- The error memory can be scrolled with the **↑** or **↓** button. Pressing the **OK** button returns you to the error memory display.

#### Resetting the error memory:

- Select **rES** and confirm with the **OK** button. **nEin** is displayed.
- Press the **↑** or **↓** button to select **JA**. Confirm the selection with the **OK** button, the error memory is cleared and **ESC** is displayed.
- To exit the error memory, select **ESC** and confirm with the **OK** button.

#### Note

The most recent error is saved to error space 1, the oldest error is saved to error space 30.

## 12 ERROR TABLE

Display (flashing)	Info	Error/warning	Possible cause	Remedy
<b>F01</b>	Message appears after exiting programming mode.	Error, memory mode	The control <b>cannot</b> save the changes.	This malfunction cannot be rectified on site. Replace control or send for repair.
<b>F02</b>	Message appears after a start command.	Error, motor triac.	Motor connection cable defective. Control defective.	Check motor connection cable. Replace control or send for repair.
<b>F03</b>	Teach-in of operating times is <b>not</b> started or interrupted.	Configuration of the control is unsuitable for performing self teach-in.	The start inputs are not programmed as default.	Set menu <b>P28</b> to <b>Stan</b> , see also <b>7.22 on page 23</b> .
			A safety device was triggered during teach-in or has been activated in the menu but is not connected.	Check safety devices or deactivate during teach-in.
			The ADI interface is activated.	Set menu <b>P46</b> to <b>nEin</b> , see also <b>7.37 on page 27</b> .
<b>F04</b>	Message appears after a start command.	Error, limit switch.	The opener has been released.	Lock opener, see.
			The opener was released in an end position and engaged again at the other end position without the mains supply being switched off.	Briefly switch off mains supply. See also <b>10.5 on page 31</b> .
			Incorrect arrangement of end position magnets	Check arrangement of end position magnets (blue = right, red = left), change positions if necessary.
			End position magnet distance too large.	To check, release opener, slide gate to open or closed end position and monitor control display. In intermediate position = both bars at top, left magnet in front of reed contact = last bar at bottom, right magnet in front of reed contact = penultimate bar at bottom. See ... Check distance between end magnets, check reed contact and adjust if necessary, max. distance 38 mm.
			Reed contact or reed contact connection line defective.	Check for damage to connection line or improper connection to control. Replace reed contact if necessary.
		Control defective.	Send control for repair or replace.	
<b>F05</b>	Message appears after a start command or when gate moving.	Stop circuit was active.	Stop or emergency stop circuit at terminals J3 and J4 was interrupted or opened when the gate was moving, see <b>"5.6 Stop input" on page 14</b> .	Close stop circuit. If no stop circuit (terminals J3/J4) is connected, a wire jumper must be connected between terminals J3 and J4 or menu <b>P29</b> must be set to <b>AUS</b> .
			<b>Note:</b> The automatic gate closing function is locked when the stop circuit is actuated and must be restarted by a start command.	
<b>F07</b>	Message appears when attempting to start programming mode.	Control settings cannot be modified.	Control configuration mode is locked.	To unlock, the programming key with which the control was locked is required. This must be inserted into the <b>"ADI"</b> interface.
<b>F08</b>	Message appears after a start command in close direction or during closing.	CLOSE light barrier was active.	Light barrier at terminals J6 and J9 was interrupted or actuated, see <b>"7.25 Photocell 2 input (terminals J6/J9)" on page 24</b> .	Remove obstacle which triggered the light barrier and/or check and replace the light barrier if necessary. When no light barrier is connected, menu <b>P31</b> must be set to <b>AUS</b> .
<b>F09</b>	Message appears after a start command in close direction.	CLOSE closing edge protection was active.	Closing edge protection at terminals J8 and J9 was interrupted or actuated, see <b>"7.28 Closing edge protection 2 (terminals J8/J9) input" on page 25</b> .	Remove obstacle which triggered the closing edge protection and/or check and replace the closing edge protection/supply line if necessary. When no closing edge protection is connected, menu <b>P34</b> must be set to <b>nEin</b> .
			Incorrect evaluation activated, see <b>"7.29 Evaluation of the closing edge protection" on page 25</b> .	Set correct evaluation in menu <b>P35</b> .
<b>F11</b>	Message appears after a start command.	Error, encoder.	The connection to the encoder has been interrupted or the encoder is damaged.	Check connection or replace encoder.
<b>F12</b>	Message appears after a start command.	Thermal protection.	Opener thermal protection has triggered.	Allow motor to cool and check function again.
<b>F13</b>	Message appears after a start command.	Error when testing ADI module.	Loose ADI module connection or module defective	Check plug connection and replace ADI module if necessary.



Display (flashing)	Info	Error/warning	Possible cause	Remedy
<b>F15</b>	Message appears after a start command.	Error when testing CLOSE closing edge protection.	CLOSE closing edge protection was active during testing.	Check connection and function of closing edge protection and associated evaluation device.
			Closing edge protection was activated, but no closing edge protection is connected.	Deactivate closing edge protection in menu <b>P34</b> . See <b>Page 24</b> .
			Incorrect evaluation type set.	Set correct evaluation type in menu <b>P35</b> . See <b>"Evaluation of the closing edge protection" on page 25</b> .
			The closing edge protection input has been short-circuited with a wire jumper.	Remove wire jumper, connect closing edge protection and corresponding evaluation device or deactivate closing edge protection in menu <b>P34</b> if not present.
<b>F20</b>	Message appears after a start command in open direction or during opening.	Force shutdown during gate opening	The gate is running sluggishly/unevenly	Correct gate run, teach in opener again if necessary or adjust value in menu <b>P39.o</b> or <b>P40.o</b> .
			There is an obstacle in the gate area	Remove obstacle.
<b>F26</b>	Message appears after a start command in close direction or during closing.	Force shutdown during gate closing	The gate is running sluggishly/unevenly	Correct gate run, teach in opener again if necessary or adjust value in menu <b>P39.c</b> or <b>P40.c</b> .
			There is an obstacle in the gate area	Remove obstacle.
<b>F27</b>	Message appears after a start command in close direction or during closing.	5x force shutdown or closing edge protection in succession during gate closing. (Error indicator only appears if automatic gate closing is selected).	The gate is running sluggishly/unevenly	Correct gate run, teach in opener again if necessary or adjust value in menu <b>P39.c</b> or <b>P40.c</b> .
			There is an obstacle in the gate area	Remove obstacle.
			The closing edge protection is defective	Check the closing edge protection and replace if necessary. The opener must be restarted by a command.
<b>Note:</b> The automatic gate closing function is locked and must be restarted by a start command.				
<b>F31</b>	Message appears after a start command or when gate moving.	Light barrier type 1 was active.	Light barrier at terminals J5 and J9 was interrupted or actuated, see <b>"7.24 Photocell 1 input (terminals J5/J9)" on page 24</b> .	Remove obstacle which triggered the light barrier and/or check and replace the light barrier if necessary. When no light barrier is connected, menu <b>P30</b> must be set to <b>AUS</b> .
<b>F32</b>	Message appears after a start command in open direction or during opening.	OPEN closing edge protection was active.	Closing edge protection at terminals J7 and J9 was interrupted or actuated, see <b>"7.27 Closing edge protection 1 (terminals J7/J9) input" on page 24</b> .	Remove obstacle which triggered the closing edge protection and/or check and replace the closing edge protection/supply line if necessary. When no closing edge protection is connected, menu <b>P33</b> must be set to <b>nEin</b> .
			Incorrect evaluation activated, see <b>"7.29 Evaluation of the closing edge protection" on page 25</b> .	Set correct evaluation in menu <b>P35</b> .
<b>F33</b>	Message appears after a start command.	Error when testing OPEN closing edge protection.	OPEN closing edge protection was active during testing.	Check connection and function of closing edge protection and associated evaluation device.
			Closing edge protection was activated, but no closing edge protection is connected.	Deactivate closing edge protection in menu <b>P33</b> . See <b>Page 24</b> .
			Incorrect evaluation type set.	Set correct evaluation type in menu <b>P35</b> . See <b>"Evaluation of the closing edge protection" on page 25</b> .
			The closing edge protection input has been short-circuited with a wire jumper.	Remove wire jumper, connect closing edge protection and corresponding evaluation device or deactivate closing edge protection in menu <b>P33</b> if not present.
<b>F37</b>	Message appears after a start command.	Error when testing light barrier type 1	Light barrier was active during testing.	Check light barrier or supply line to light barrier and replace if necessary. Remove obstacle.
			A light barrier was activated, but no light barrier is connected.	Deactivate light barrier in menu <b>P30</b> . See <b>Page 24</b> .
			The light barrier input has been short-circuited with a wire jumper.	Remove wire jumper and deactivate light barrier in menu <b>P30</b> . See <b>Page 24</b> .
<b>F38</b>	Message appears after a start command.	Error when testing light barrier type 2	Light barrier was active during testing.	Check light barrier or supply line to light barrier and replace if necessary. Remove obstacle.
			A light barrier was activated, but no light barrier is connected.	Deactivate light barrier in menu <b>P31</b> . See <b>Page 24</b> .
			The light barrier input has been short-circuited with a wire jumper.	Remove wire jumper and deactivate light barrier in menu <b>P31</b> . See <b>Page 24</b> .

## 13 "-PRG" MENU FUNCTION OVERVIEW

DISPLAY	ENTRY	DESCRIPTION	STANDARD VALUE	Set value
P03	0 - 100%	Partially open position (percentage of total opening)	25	
P10		Direction logic:	rEC	
	rEc	• The gate opens to the right.		
	Lin	• The gate opens to the left.		
P13.o	0.5" - 1.0'	Warning light pre-warning time in open direction.	AUS	
	AUS	"Warning light pre-warning time in open direction" function deactivated.		
P13.c	0.5" - 1.0'	Warning light pre-warning time in close direction.	AUS	
	AUS	"Warning light pre-warning time in close direction" function deactivated.		
P14.o	30 - 100%	Running speed in open direction.	40	
P14.c	30 - 100%	Running speed in close direction.	40	
P14.S	0 - 70 %	Soft stop speed, max. ≤ P14.o or P14.c	20	
P16	JA/nEin	Switch off of motor power regulation on start-up (start-up suppression).	nEin	
P17.o	0 - 4	Length of warm-up ramp in open direction.	1	
	0	"Length of warm-up ramp in open direction" function deactivated.		
P17.c	0 - 4	Length of warm-up ramp in close direction.	1	
	0	"Length of warm-up ramp in close direction" function deactivated.		
P18.o	0 - 100%	Duration of soft stop phase in open direction.	10	
	0	"Duration of soft stop phase in open direction" function deactivated.		
P18.c	0 - 100%	Length of soft stop phase in close direction.	10	
	0	"Duration of soft stop phase in close direction" function deactivated.		
P20		Start pulse on gate opening effects:	StoP	
	AUS	• Start pulse is ignored, gate continues to open.		
	ZU	• Gate stops and closes again immediately.		
	StoP	• Gate stops.		
P21		Start pulse on gate closing effects:	StoP	
	StoP	• Gate stops.		
	AUF	• Gate stops and opens again immediately.		
P22		Start pulse when gate is open effects:	ZU	
	AUS	• Start pulse is ignored, gate remains open.		
	PAUS	• Hold-open time is reset.		
P23		Start pulse on pedestrian opening effects:	StoP	
	AUS	• Start pulse is ignored, gate continues to open.		
	StoP	• Gate stops.		
P24		Automatic closing (automatic gate closing):	AUS	
	AUS	• Automatic gate closing deactivated.		
	0.5" - 20.0'	• Gate closes after set time.		
P25		Quick close function after passage.	AUS	
	AUS	• "Quick close function after passage" function deactivated.		
	0.5" - 20.0'	• Gate closes after set time.		
P25.1	JA/nEin	Quick close function only after passage of both light barriers (type 1 and type 2). Apply setting in menu P25.	nEin	
P27	JA/nEin	Warning light on open gate.	nEin	
P28		Function of start inputs (terminal J1/J2/J4):	StAn	
	nEin	• The control's start inputs are deactivated.		
	StAn	• Standard mode.		
	AU.ZU	• Defined open and close commands.		
	totb	• Deadman operation.		
	dAUF	• Continuous open on continuous signal at start input.		

DISPLAY	ENTRY	DESCRIPTION	STANDARD VALUE	Set value
P29		STOP input (terminals J3/J4) function:	AUS	
	AUS	<ul style="list-style-type: none"> <li>The STOP input is deactivated.</li> </ul>		
	St.Er	<ul style="list-style-type: none"> <li>The STOP command stops the gate. With the next START command, the gate moves in the <b>opposite</b> direction.</li> </ul>		
	St.Gr	<ul style="list-style-type: none"> <li>The STOP command stops the gate. With the next START command, the gate continues in the <b>same</b> direction.</li> </ul>		
P30		PHOTO 1 function (internal light barrier, type 1, terminals J5/J9):	AUS	
	JA	<ul style="list-style-type: none"> <li>Safety input activated.</li> </ul>		
	AUS	<ul style="list-style-type: none"> <li>Safety input deactivated.</li> </ul>		
P31		PHOTO 2 function (external light barrier, type 2, terminals J6/J9):	AUS	
	ZUPA	<ul style="list-style-type: none"> <li>Safety input active on closing and stationary gate.</li> </ul>		
	AUS	<ul style="list-style-type: none"> <li>Safety input deactivated.</li> </ul>		
	ZU	<ul style="list-style-type: none"> <li>Safety input activated only on closing.</li> </ul>		
P32	JA/nEin	Testing of PHOTO 1 and PHOTO 2 light barriers.	nEin	
P33	JA/nEin	Safety input 1 (terminals J7/J9) for safety contact strip in open direction activated.	nEin	
P34	JA/nEin	Safety input 2 (terminals J8/J9) for safety contact strip in close direction activated.	nEin	
P35		Testing/evaluation of safety contact strips:	nEin	
	nEin	<ul style="list-style-type: none"> <li>External evaluation with normally closed contact, without testing.</li> </ul>		
	8.2	<ul style="list-style-type: none"> <li>Integrated evaluation for 8k2 safety contact strips.</li> </ul>		
	rEL	<ul style="list-style-type: none"> <li>External evaluation with normally closed contact, with testing.</li> </ul>		
P39.o	1.0 A - 16.0 A	Obstacle sensor (current value) in open direction, see also " <b>Obstacle sensor in the open direction</b> " on page 25.	nEin	
	nEin	Obstacle sensor deactivated.		
P39.c	1.0 A - 16.0 A	Obstacle sensor (current value) in close direction, see also " <b>Obstacle sensor in the close direction</b> " on page 25.	nEin	
	nEin	Obstacle sensor deactivated.		
P40.o	1 - 7	Obstacle sensor (speed monitoring) in open direction, see also " <b>Obstacle sensor in the open direction</b> " on page 26.	0	
	0	Obstacle sensor deactivated.		
P40.c	1 - 7	Obstacle sensor (speed monitoring) in close direction, see also " <b>Obstacle sensor in the close direction</b> " on page 26.	0	
	0	Obstacle sensor deactivated.		
P42		Function of option relay	t.iM, 1.0'	
	t.iM, 0.5" - 20.0'	<ul style="list-style-type: none"> <li>Relay switched on for set time.</li> </ul>		
	AUS	<ul style="list-style-type: none"> <li>"Relay switched on for set time" function deactivated.</li> </ul>		
	t.LiC, 0.5" - 20.0'	<ul style="list-style-type: none"> <li>Relay is switched on when gate is moving and switches off (delayed) after set time.</li> </ul>		
	SL	<ul style="list-style-type: none"> <li>Signal light function, see also "<b>Warning/signal light output function</b>" on page 27.</li> </ul>		
P43		Radio receiver channel 2 function:	Stan	
	Stan	<ul style="list-style-type: none"> <li>Pedestrian opening.</li> </ul>		
	TiM	<ul style="list-style-type: none"> <li>Timer function, option relay switches on for time set in menu P42.</li> </ul>		
	biSt	<ul style="list-style-type: none"> <li>Bistable function, option relay changes switching status on each command.</li> </ul>		
	Mon	<ul style="list-style-type: none"> <li>Monostable function, option relay switches on for duration of command.</li> </ul>		
P44		Warning light output 24 V function.	AUS	
	AUS	<ul style="list-style-type: none"> <li>Function deactivated</li> </ul>		
	bL	<ul style="list-style-type: none"> <li>Flashing</li> </ul>		
	SL	<ul style="list-style-type: none"> <li>Signal light</li> </ul>		

DISPLAY	ENTRY	DESCRIPTION	STANDARD VALUE	Set value
P46	JA/nEin	• ADI interface active.	nEin	
ENDE		End of programming.	nEin	
	nEin	• Programming mode is not terminated.		
	Ja	• Programming mode is terminated and changed data saved.		

#### 14 "-CNT" MENU FUNCTION OVERVIEW

DISPLAY	ENTRY	DESCRIPTION	STANDARD VALUE	Set value
		Display of cycle and maintenance counter:	tot	
	tot	- Display executed cycle count.		
	ESC	- Exit menu.		
	MAAn	- Maintenance counter (value 0 = maintenance counter deactivated).		

#### 15 "-ERR" MENU FUNCTION OVERVIEW

DISPLAY	ENTRY	DESCRIPTION	STANDARD VALUE
		Error memory display:	ESC
1	F.. / -- --	Error memory space 1.	
2	F.. / -- --	Error memory space 2.	
3	F.. / -- --	Error memory space 3.	
4	F.. / -- --	Error memory space 4.	
5	F.. / -- --	Error memory space 5.	
...	...		
29	F.. / -- --	Error memory space 29.	
30	F.. / -- --	Error memory space 30.	
rES	JA/nEin	Clear error memory.	
ESC		Exit menu.	

#### 16 "-LRN" MENU FUNCTION OVERVIEW

DISPLAY	ENTRY	DESCRIPTION	STANDARD VALUE
		Run time teach-in:	nEin
	nEin	Run times are <b>not</b> taught in.	
	JA	Run times are taught in <b>again</b> .	

#### 17 "-DEF" MENU FUNCTION OVERVIEW

DISPLAY	ENTRY	DESCRIPTION	STANDARD VALUE
		Loading of standard values:	nEin
	nEin	Standard values are not loaded.	
	JA	Standard values are loaded.	



18 CONNECTION OVERVIEW

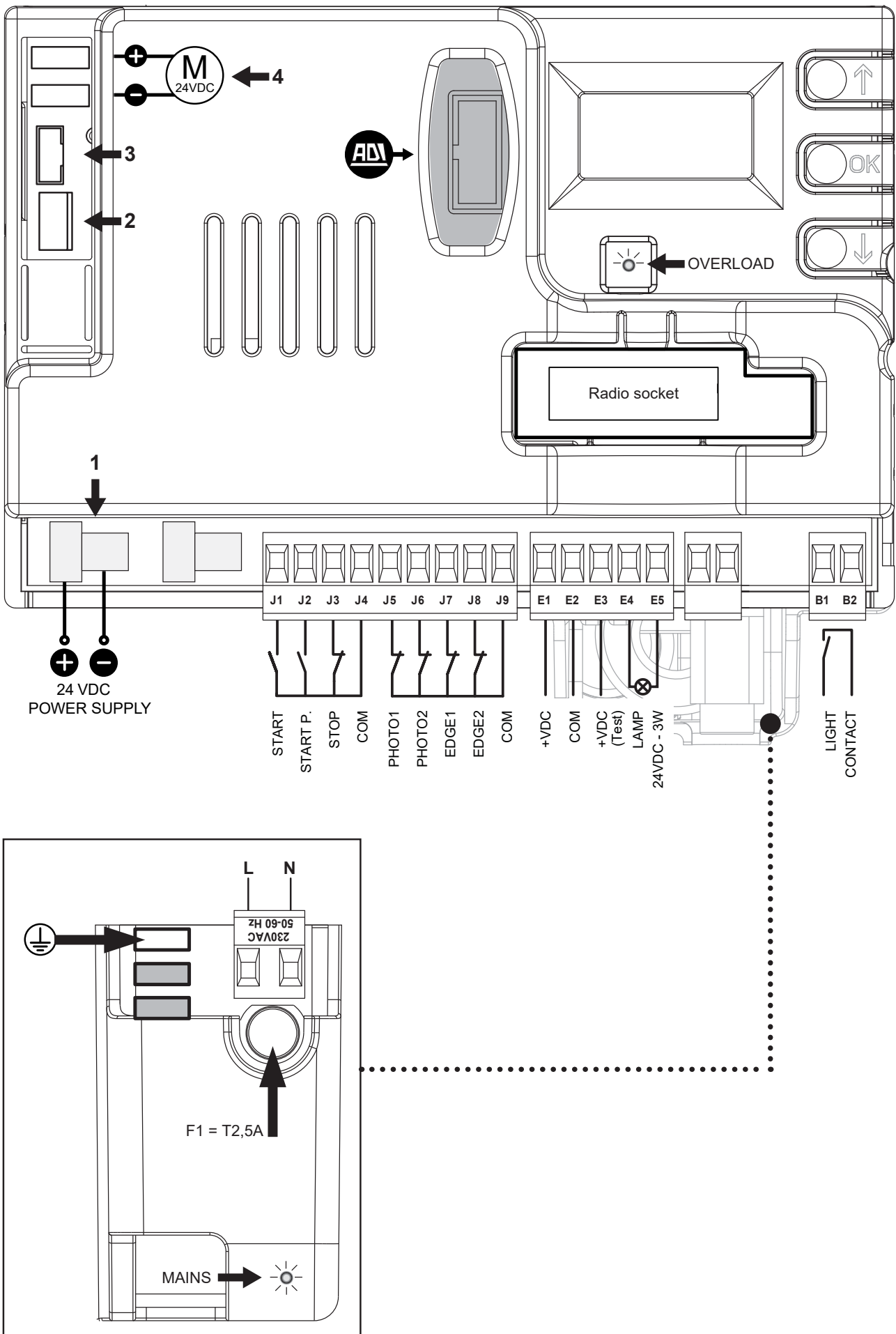

<b>J1-J4</b>	Command input (START) for key switch, push button (floating normally open contact)
<b>J2-J4</b>	Command input (START P) for partial opening (floating normally open contact)
<b>J3-J4</b>	STOP input (floating normally closed contact)
<b>J4</b>	Common earth/ground (GND)
<b>J5-J9</b>	Light barrier type 1 (floating normally closed contact), active in open and close direction
<b>J6-J9</b>	Light barrier type 2 (floating normally closed contact), active in close direction
<b>J7-J9</b>	Contact strip OPEN (8k2 or floating normally closed contact)
<b>J8-J9</b>	Contact strip CLOSE (8k2 or floating normally closed contact)
<b>J9</b>	Common earth/ground (GND)
<b>E1</b>	Voltage output 24 V DC, max. 400 mA
<b>E2</b>	Voltage output, earth/ground (GND)
<b>E3</b>	Voltage output 24 V DC for function test; deactivated for test

<b>E4-E5</b>	Warning light connection 24 V DC/max. 3 W
<b>L</b>	L1 of mains supply 230 V AC/50 Hz
<b>N</b>	N of mains supply 230 V AC/50 Hz
<b>B1-B2</b>	Lighting (floating option relay)
<b>F1</b>	Microfuse 2 A (safeguard for 230 V AC circuit)
<b>MAINS</b>	Operating LED, lights up when voltage present
<b>OVERLOAD</b>	Overload indicator for 24 V AC output, lights up on overload
<b>ADI</b>	ADI interface for additional modules
<b>↑</b>	"Up" function button or START
<b>OK</b>	OK function button
<b>↓</b>	"Down" function button or START P
	Factory set connections, must not be modified
<b>1</b>	Voltage supply of control 24 V DC
<b>2</b>	Encoder connection
<b>3</b>	Reed contact connection (end position sensor)
<b>4</b>	Motor connection

19 CABLE LAYING DIAGRAM

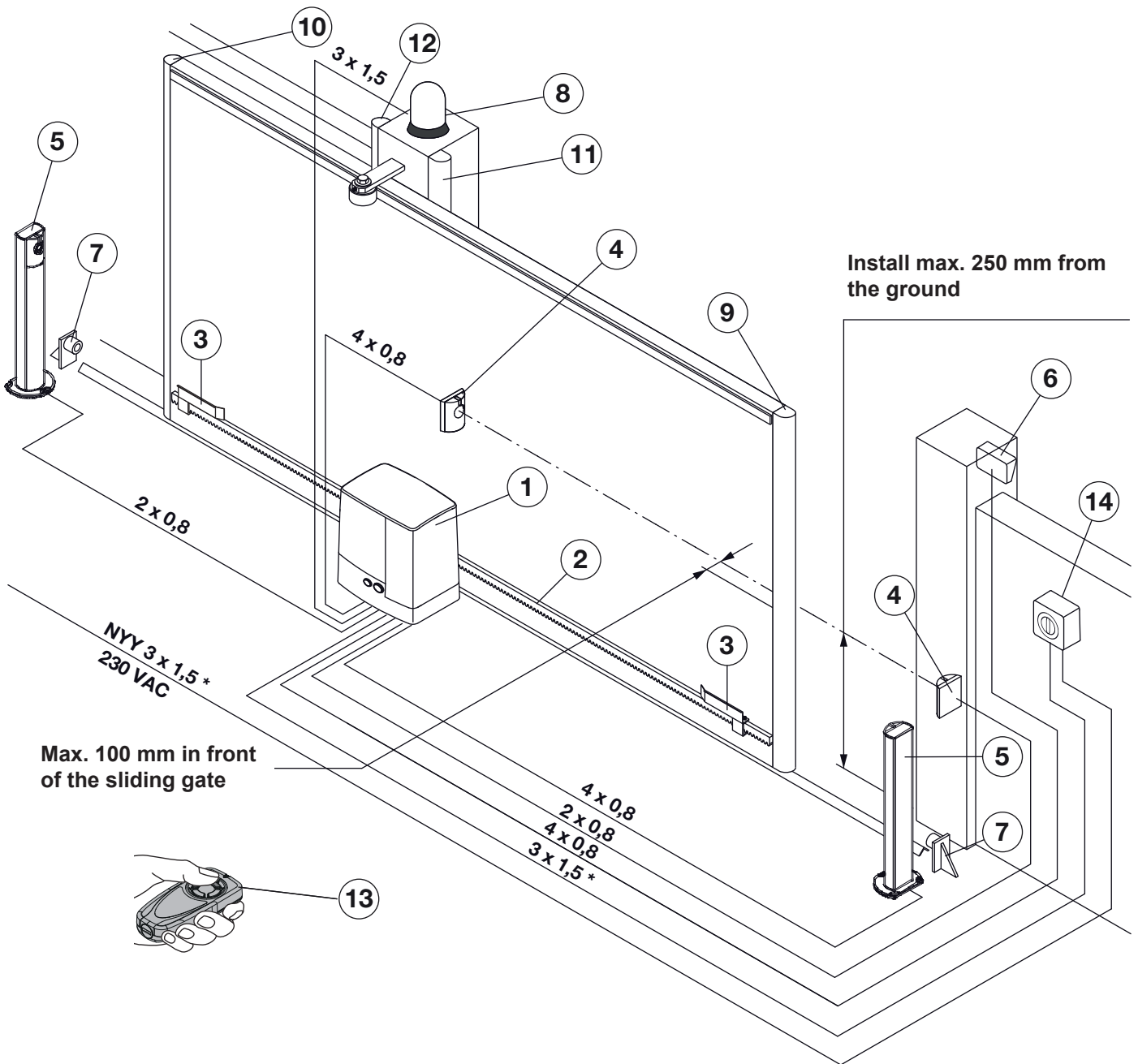

Cable laying diagram

1	Sliding opener	2	Gear rack	3	Limit switch bracket with magnet
4	Light barrier type 2 (external)/transmitter (TX) and receiver (RX)	5	Light barrier type 1 (internal)/transmitter (TX) and receiver (RX)	6	Key switch/command unit
7	Mechanical end stop, open/close (overrun protection)	8	Warning light/flashing light with flasher unit/warning beacon	9	Safety contact strip, 8k2, mobile, main closing edge in close direction
10	Safety contact strip, 8k2, mobile, main closing edge in open direction	11	Safety contact strip, 8k2, stationary, secondary closing edge in open direction	12	Safety contact strip, 8k2, stationary, secondary closing edge in close direction
13	Handheld transmitter	14	Main switch, all-pole-disconnecting and lockable		



## 20 DISASSEMBLY AND DISPOSAL

### Note

Observe all applicable occupational safety regulations during disassembly.

Have the gate opener disassembled and properly disposed of by an expert, in accordance with this manual and in reverse order.

## 21 OPTIONAL ACCESSORIES

Optional accessories are **not** included in the scope of supply. The load on the opener from all electrical accessories must not exceed **maximum 300 mA**.

### The following accessories are available:

- External radio receivers
- External pulse buttons (e.g. key switches)
- External code and transponder buttons
- Through-beam light barriers
- Warning/signal lights
- Safety contact strips 8k2
- Inductive transfer system for safety contact strip 8k2
- Radio transfer system for safety contact strip 8k2

## 22 WARRANTY CONDITIONS

### 22.1 Warranty

We are released from the warranty and from product liability obligations if structural modifications are undertaken without first obtaining our permission, or installation is arranged or carried out incorrectly, contrary to our specified installation instructions. Moreover, we do not accept any responsibility for the accidental or negligent operation of the opener and of accessories, not for improper maintenance of the gate and its counterweight. Batteries and bulbs are also excluded from warranty claims.

### 22.2 Duration of the guarantee

In addition to the statutory warranty provided by the dealer from the bill of sale, we provide the following partial guarantee from the date of purchase:

- **2 years** on the mechanical systems of the opener, the motor and control
- **2 years** on radio equipment, accessories and special systems

There is no claim to a guarantee on consumables (e.g. fuses, batteries, bulbs).

Claims under warranty do **not** extend the guarantee period. The guarantee term on spare parts deliveries and repair work is six months, however no less than the remaining duration of the guarantee.

### 22.3 Requirements

The right to claim under the guarantee only applies to the country of purchased of the device.

The goods must have been purchased through the sales channel specified by us.

Guarantee claims may only cover damage to the object of the contract.

Reimbursement of expenses for removal and installation, inspection of relevant parts, as well as claims for lost profit and damages are excluded from the guarantee.

Your proof of purchase also counts as your proof guarantee eligibility.

### 22.4 Performance

For the duration of the guarantee, we will repair all defects on the product which can be verifiably traced back to faulty materials or workmanship.

We shall be obligated, at our own discretion and free of charge, to either replace the defective goods with non-defective ones, to repair them or to refund the loss in value.

Replaced parts shall become our property.

Damage resulting from the following is excluded:

- Improper installation and connection
- Improper commissioning and operation
- External influences such as fire, water, abnormal ambient conditions
- Mechanical damage due to accident, drops, collision
- Negligent or deliberate destruction
- Normal wear or inadequate maintenance
- Repairs carried out by unqualified personnel
- Use of third-party components
- Removal or concealment of the type plate

## 23 TECHNICAL DATA

Supply voltage	230 V~/50 Hz
Current consumption	2.5 A
Power	0.55 kW
Duty cycle	40%
Protective fuse	2.5 A
Voltage output for external consumers	24 V AC/max. 300 mA
Max. traction/thrust force	900 N
Protection type	IP44
Operating temperature	-20°C/+60°C
Max. weight of gate	1000 kg *
Module	M4 -Z18
Operating speed	35 mm/s - 260 mm/s
Gear lubrication	Grease
Weight	18 kg

### Note

\* The weight information relates to ground-running sliding gates. With cantilever gates, subtract 20% from the max. gate weight.

**Instructions for Fitting, Operating and Maintenance**  
Sliding operator

# CX1024

**4Ddoors**  
GARAGE DOORS REDEFINED