

Instructions for Fitting, Operating and Maintenance
Sliding operator

C300-500-800

4Ddoors

GARAGE DOORS REDEFINED

www.4Ddoors.com

ENGLISH **7**

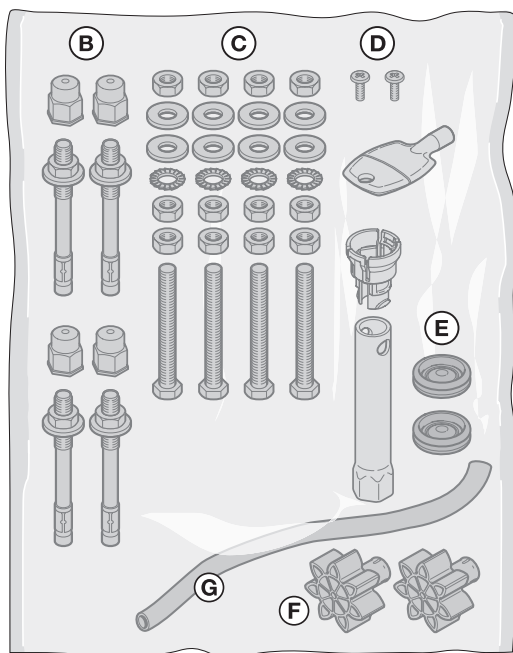
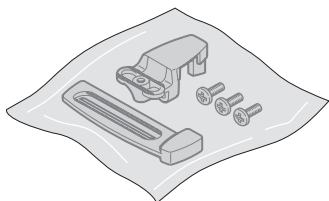
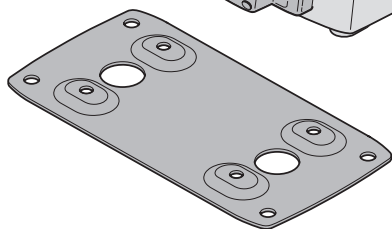
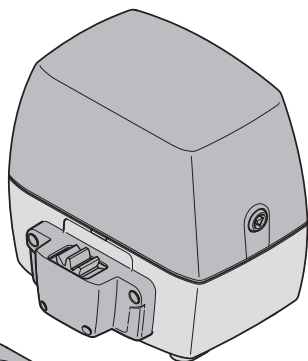
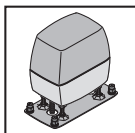
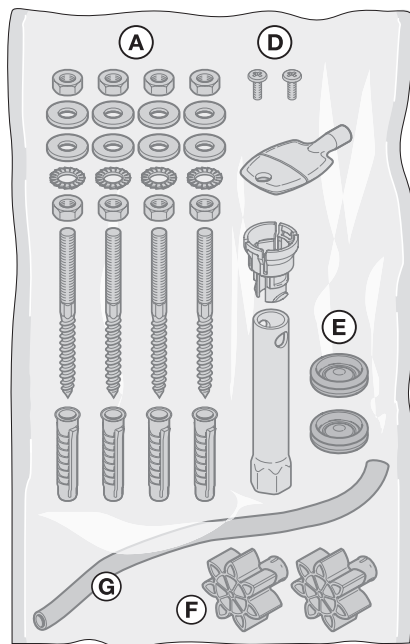
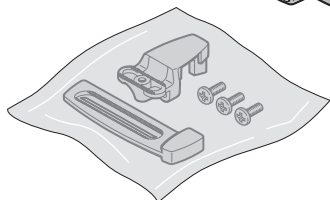
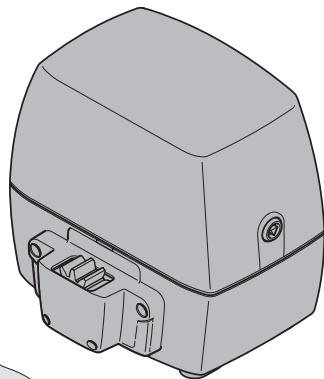
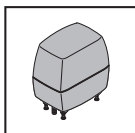

..... **24**

A

B

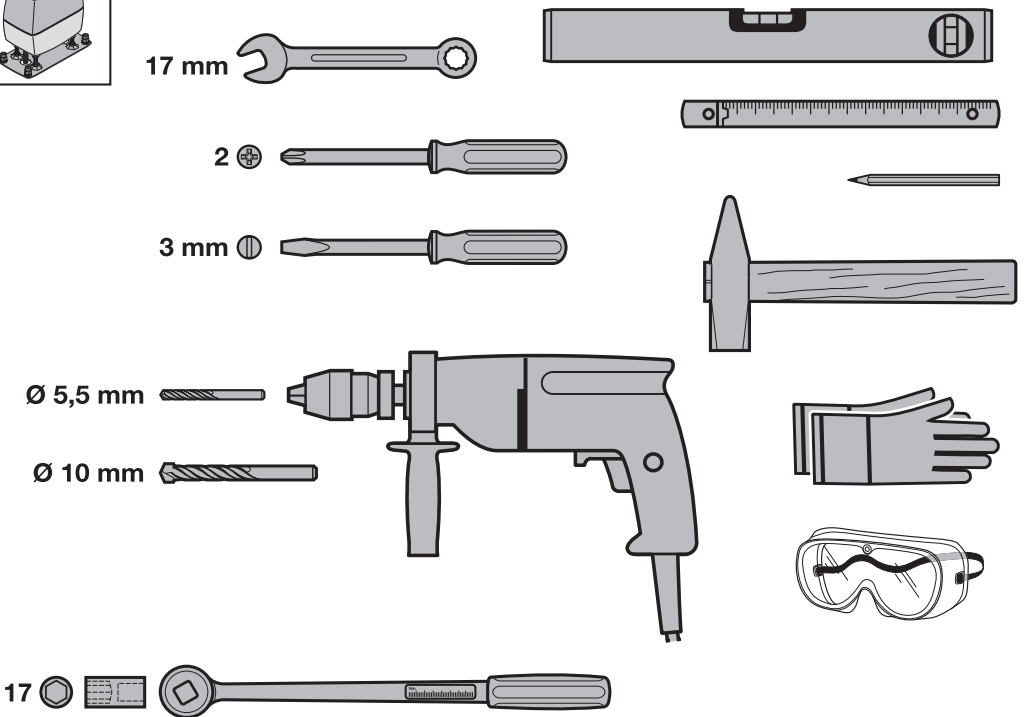
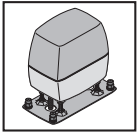
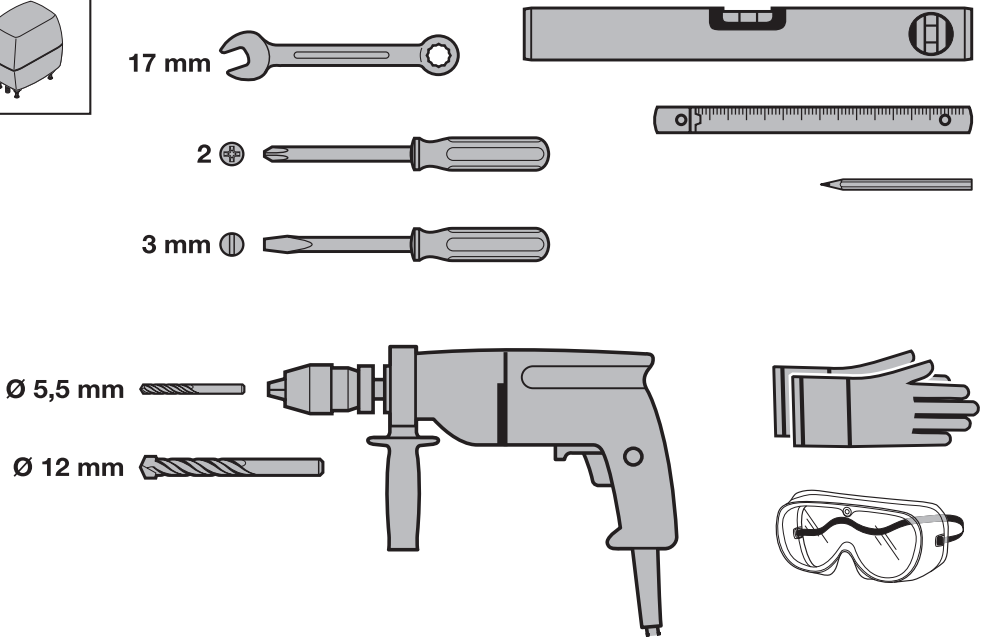
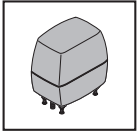

C₁

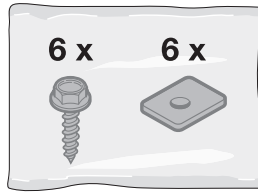

716 0066

C₂ 716 0001

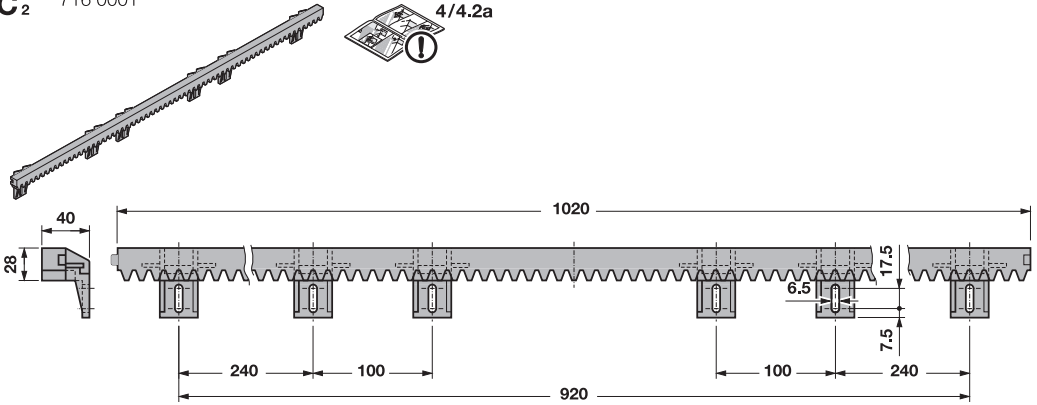

C₃ 716 0065

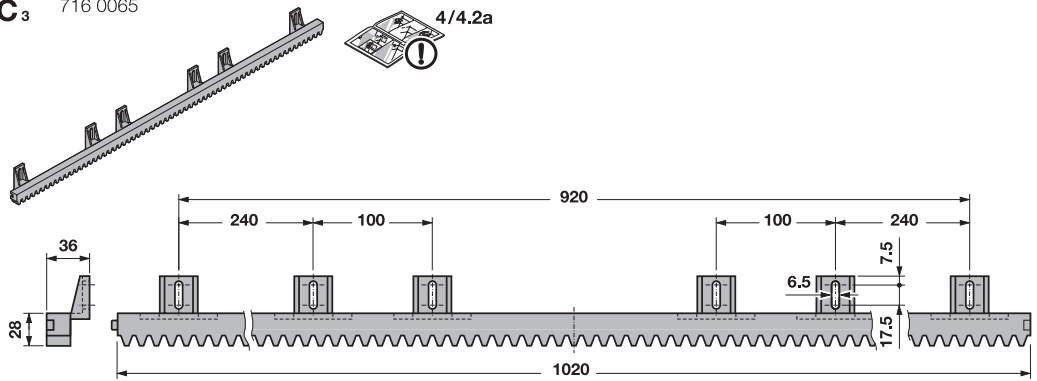

C₄ 716 0002

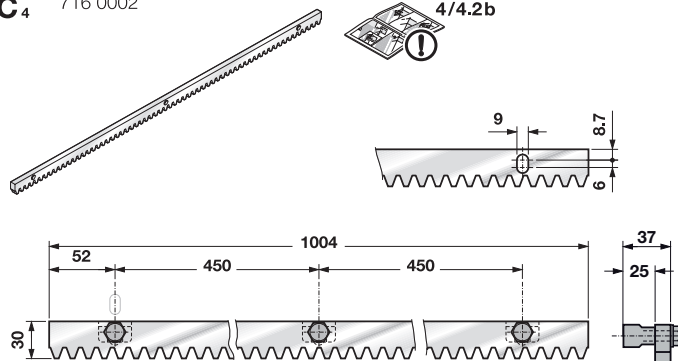

C₅

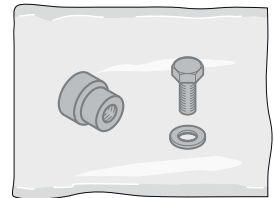

Contents

A	Articles supplied	3
B	Tools needed to assemble the sliding gate operator	4
C₁	Installation accessories for the plastic toothed tracks	5
C₂	Plastic toothed track with steel core (fitting bracket at bottom)	5
C₃	Plastic toothed track with steel core (fitting bracket at top)	5
C₄	Galvanized steel toothed track	5
C₅	Fitting accessories for steel toothed tracks	5
1	About These Instructions	8
1.1	Warnings used	8
1.2	Definitions	8
1.3	Symbols used	9
1.4	Notices on illustrated section	9
2	⚠ Safety Instructions	9
2.1	Intended use	9
2.2	Non-intended use	9
2.3	General safety instructions	9
2.4	Safety instructions for fitting	10
2.5	Safety information for electrical work	10
3	Fitting	10
3.1	Fitting the sliding gate operator	10
3.1.1	Foundation	10
3.1.2	Establishing the fitting dimensions	10
3.1.3	Fixing	11
3.1.4	Fitting the operator housing	11
3.2	Fitting the toothed track	11
3.3	Connecting the mains lead	11
3.4	Fitting the print bracket	11
3.5	Fitting the magnet bracket	11
3.6	Locking the operator	11
3.7	Connecting additional components/accessories	11
3.7.1	Connecting an external radio receiver	12
3.7.2	Connecting an external button*	12
3.7.3	Connecting a cut-out to stop the operator (STOP or emergency-OFF circuit)	12
3.7.4	Connecting a warning lamp*	12
3.7.5	Connecting safety/protective devices	12
3.7.6	Connecting a universal adapter print UAP1*	12
4	Putting into Service	12
4.1	Preparation	12
4.2	Teaching in the gate's end-of-travel positions	12
4.2.1	Recording the CLOSE end-of-travel position	12
4.2.2	Recording the OPEN end-of travel position	13
4.2.3	Recording the partial opening end-of-travel position	13
4.2.4	Completion of set-up mode	13
4.2.5	Reference run	13
4.3	Learning the forces	13
4.3.1	Setting the force limit	13
4.3.2	Operator speed	14
4.3.3	Switching off the force limit	14
4.4	Changing the starting point for slow speed when opening and closing	14
4.5	Reversal limit	14
4.6	Automatic timed closing	14
5	DIL Switch Functions	15
5.1	DIL switch 1	15
5.2	DIL switch 2	15
5.3	DIL switch 3/DIL switch 4	15
5.4	DIL switch 5/DIL switch 6	15
5.5	DIL switch 7	15
5.6	DIL switch 8/DIL switch 9	15
5.7	DIL switch 10	16
5.8	DIL switch 11	16
5.9	DIL switch 12	16
5.10	DIL switch 13	16
5.11	DIL switch 14	16
5.12	DIL switch 15	16
5.13	DIL switch 16	16
6	Radio	16
6.1.	Important information for using the hand transmitter	17
6.2	Radio Remote Control	17
6.2.1	External radio receiver	17
7	Operation	17
7.1	Instructing users	18
7.2	Function check	18
7.3	Normal mode:	18
7.4	Behaviour during a power failure	18
7.5	Behaviour following a power failure	18
8	Inspection and Maintenance	18
9	Operation, Error and Warning Messages	18
9.1	LED GN	18
9.2	LED RT	18
9.3	Error/diagnosis display	18
9.4	Error acknowledgement	19
10	Factory Reset	19
11	Dismantling and Disposal	19
12	Optional Accessories	19
13	Warranty Conditions	19
14	Technical Data	20
15	Overview of DIL Switch Functions	21
	Illustrated section	24-41



Illustrated section.....24-41

* Accessory, not included as standard equipment!

Dissemination as well as duplication of this document and the use and communication of its content are prohibited unless explicitly permitted. Noncompliance will result in damage compensation obligations. All rights reserved in the event of patent, utility model or design model registration. Subject to changes.

Dear Customer,

We are delighted that you have chosen a quality product from our company.

1 About These Instructions

These instructions are divided into a text section and an illustrated section. The illustrated section can be found after the text section.

Read through all of the instructions carefully, as they contain important information about the product. Pay attention to and follow the instructions provided, particularly the safety instructions and warnings.

Keep these instructions in a safe place for later reference!

1.1 Warnings used

ATTENTION

Indicates a danger that can lead to **damage or destruction of the product**.



The general warning symbol indicates a danger that can lead to **injury or death**. In the text section, the general warning symbol will be used in connection with the caution levels described below. In the illustrated section, an additional instruction refers back to the explanation in the text.

CAUTION

Indicates a danger that can lead to minor or moderate injuries.

WARNING

Indicates a danger that can lead to death or serious injuries.

DANGER

Indicates a danger that leads directly to death or serious injuries.

1.2 Definitions

Hold-open phase

Waiting phase at the *OPEN* end-of-travel position or partial opening before the gate closes during automatic timed closing

Automatic timed closing

Automatic timed closing of the gate after a set time has elapsed and after reaching the *OPEN* end-of-travel position or partial opening.

DIL switches

Switches on the control print for setting the control.

Through-traffic photocell

When the gate is passed through, the photocell shortens the hold-open phase and the gate closes a short time thereafter.

Impulse control

A sequence of impulses which allows the gate to alternately OPEN-STOP-CLOSE-STOP.

Force training run

A learning run during which the necessary forces for moving the gate are taught in.

Normal cycle

Gate movement with the taught-in travel distances and forces.

Reference run

Gate cycle towards the *CLOSE* end-of-travel position in order to set the home position.

Reversing cycle

Gate travel in the opposite direction when the safety device is activated.

Reversal limit

The reversal limit separates the area between reversal or stopping of the gate when the force is cut off.

Slow speed

The area in which the gate moves very slowly, in order to gently move to the travel limit.

Press-and-release operation

After an impulse is sent, the operator independently moves into the end-of-travel position.

Partial opening

The distance the gate is opened for pedestrian traffic.

Press-and-hold operation

The gate travels only as long as the respective buttons are pressed.

Full opening

The travel to completely open the gate.

Warning phase

The time between the travel command (impulse) and the start of travel.

Factory reset

Resetting the taught-in values to the delivery status/ex factory setting







Colour code for cables, single conductors and components

The abbreviations of the colours for identifying the cables, conductors and components comply with the international colour code according to IEC 757:

BK	Black	PK	Pink
BN	Brown	RD	Red
BU	Blue	SR	Silver
GD	Gold	TQ	Turquoise
GN	Green	VT	Violet
GN/YE	Green/yellow	WH	White
GY	Grey	YE	Yellow
OG	Orange		

1.3 Symbols used

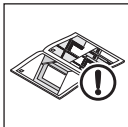
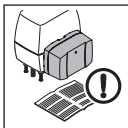
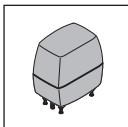
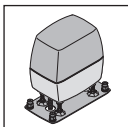
Symbols

	Important note for avoiding damage to property
	Permissible arrangement or activity
	Non-permissible arrangement or activity
	See text section In the example, 2.2 means: See text section 2.2
	See illustrated section
	If necessary, see the separate fitting instructions for the emergency battery
	Standard sliding gate operator
	Reinforced sliding gate operator
	Power failure
	Restore power



Audible engagement



DIL switch factory setting

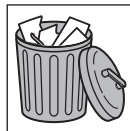

Remove and dispose of component or packaging

1.4 Notices on illustrated section

The illustrated section shows the operator fitting of an operator without a base plate to the inside right of the closed sliding gate. Where fitting or programming differs for an operator with base plate or for a sliding gate with the operator attached to the inside left of the closed sliding gate, this is shown in addition.

All dimensions in the illustrated section are in [mm].

2  Safety Instructions

For safe handling and maintenance of the gate system, these instructions and the test log book must be placed at the disposal of the end user.

2.1 Intended use

The sliding gate operator is exclusively intended for the private operation of smooth-running sliding gates, depending on the operator type. The maximum permissible gate size and maximum weight must not be exceeded.

Note the manufacturer's specifications regarding the gate and operator combination. Possible hazards as defined in EN 12604, EN 12605, EN 12445 and EN 12453 are prevented by the design itself and by carrying out fitting in accordance with our guidelines. Gate systems used by the general public and equipped with a single protective device, e.g. force limit, may only be used when monitored.

2.2 Non-intended use

Continuous operation and use on gates with a gradient or slope is not permitted. In addition, use in the commercial sector is prohibited, depending on the operator type.

2.3 General safety instructions

 WARNING
Danger of injury due to a defect in the gate system
A malfunction in the gate system or an incorrectly aligned gate can cause serious injury
▶ Do not use the gate system if repair or adjustment work must be conducted.

- Fitting, maintenance, repair and dismantling of the sliding gate operator may only be carried out by specialists (competent persons in accordance with EN 12635).

- The gate must be mechanically secured to prevent it from running out of its guides.
- In addition, check the entire gate system (joints, gate bearings and fastenings) for wear and possible damage. Check for signs of rust, corrosion or fractures.
- In the event of a gate system failure (sluggish operation or other malfunctions), a specialist must be commissioned immediately for the inspection/repair work.
- If you observe these instructions, as well as the following conditions, you can assume that the operating forces are complied with according to DIN EN 12453:
 - The centre of gravity for the gate must be in the centre of the gate (maximum permissible deviation $\pm 20\%$).
 - The gate is easy to move and does not have any gradients/slopes (0%).
 - A DP3 (article no.: 309 0083) sound-absorbing seal is fitted to the closing edge(s).
 - The operator is programmed for slow speed (see section 4.3.2).
 - The reversal limit at 50 mm opening width has been checked and maintained over the entire length of the main closing edge.
 - The distance between the supporting rollers in self-supporting gates (maximum width 6200 mm, maximum opening width 4000 mm) is max. 2000 mm.

2.4 Safety instructions for fitting

WARNING

Unwanted gate travel
 Incorrectly attached control devices (e.g. buttons) may trigger unwanted gate travel. Persons or objects may be trapped as a result.



- ▶ Install control devices at a height of at least 1.5 m (out of the reach of children).
- ▶ Fit permanently installed control devices (such as buttons, etc.) within sight of the gate, but away from moving parts.

Observe the following points during fitting:

- The installer must ensure that the applicable regulations on occupational safety, as well as the regulations on the operation of electrical devices, are complied with. The relevant national guidelines must be observed.
- Before fitting the operator, make sure that the gate is free of mechanical defects and can also be easily operated by hand (EN 12604).
- Prior to fitting the operator, immobilize any mechanical locks not needed for power operation of the sliding gate. This includes in particular any locking mechanisms connected with the gate lock.
- Check that the fitting materials supplied are suitable for the purpose and the intended fitting location.
- After fitting has been completed, the installer of the gate system must declare conformity with DIN EN 13241-1 in accordance with the scope of application.

2.5 Safety information for electrical work

DANGER

Dangerous electrical voltage
 Mains voltage is necessary for operating this device. Improper use can cause electrical shocks which can lead to death or serious injuries.

- ▶ Electrical connections may only be made by a qualified electrician!
- ▶ The on-site electrical installation must conform to the applicable protective regulations (230/240 V AC, 50/60 Hz)!
- ▶ Qualified electricians must ensure compliance with the national directives for the operation of electrical devices!
- ▶ In order to avoid malfunctions, make sure that the operator's connection cables (24 V DC) are laid out in a separate installation system from other supply lines (230/240 V AC).
- ▶ The mains voltage must be disconnected before performing any work on the operator.

3 Fitting

3.1 Fitting the sliding gate operator

3.1.1 Foundation

1. A foundation must be laid (see **Figure 1a/Figure 1b**).
 The  mark represents the frost-free depth (in Germany = 80 cm).
 A larger foundation must be laid if using a closing edge safety device (see **Figure 1c/Figure 1d**).
2. Concrete \geq B25/C25 (compacted) must be used with the operator type with base plate.
3. A base foundation may be required for gates with inside rollers.
4. The 230/240 V AC mains lead must be routed through an empty tube in the foundation. The lead to connect 24 V accessories must be installed in an empty tube that is separated from the mains lead (see **Figure 1.1**).

NOTE:

The foundation must have set and dried sufficiently before the following work is carried out!

3.1.2 Establishing the fitting dimensions

1. Mark the drill position of the four drill holes on the surface of the foundation.
 Depending on the operator, use:
 - The drill stencil at the back of these instructions for \varnothing 12 mm holes with stock screws (see **Figure 2a**).
 - The base plate for \varnothing 10 mm holes with heavy-duty anchors (see **Figure 2b**).
2. Select the toothed track to be used from the table below and find the minimum and maximum fitting dimensions (dimension A).

Toothed track	Dimension A (mm)	
	Min.	Max.
716 0002	126	138
716 0065	125	129
716 0001	129	133

3.1.3 Fixing

- ▶ See **Figures 2a.1/2b.1**
- ▶ After drilling, check the depth of the hole.

Hole	Depth
Ø 12 mm for stock screws	80 mm
Ø 10 mm for heavy-duty anchors	105 mm

- ▶ Use the socket wrench included in the scope of delivery to install the stock screws.

3.1.4 Fitting the operator housing

- ▶ See **Figures 3 – 3.5**

ATTENTION!

Damage due to moisture

- ▶ Protect the control from moisture when you open the operator housing
- ▶ Open the operator housing and release the operator. The motor and pinion are lowered in the housing when the operator is released.
- ▶ If necessary, cut the tube seals to fit the tubes.
- ▶ When the housing is placed on the stock screws or base plate, pull the mains lead and, if necessary, the 24 V connecting lead from below through the tube seals and into the housing without any distortion.
- ▶ When tightening, pay attention that it is horizontal, stable and securely fastened.

3.2 Fitting the toothed track

Before fitting:

- ▶ Check that required hole depths are available.
- ▶ To fit the toothed tracks, use the connectors (bolts and nuts, etc.) from the fitting accessories (see **Figure C1** or **Figure C5**, must be ordered separately).

NOTE:

- Contrary to the illustrated section, use the appropriate connectors (e.g. for timber gates use woodscrews), as well as the proper hole depths for other gate types.
- Contrary to the illustrated section, the required core hole diameter may vary depending on material thickness or strength. The required diameter may be Ø 5.0-5.5 mm for aluminium and Ø 5.7-5.8 mm for steel.

Fitting:

- ▶ See **Figures 4 – 4.3**

ATTENTION

Damage caused by dirt

Drilling dust and chippings from drilling work can lead to malfunctions.

- ▶ Cover the operator during drilling work.

The sliding gate operator must be released (see **Figure 3.2**).

- ▶ When fitting the toothed tracks, make sure that the transitions between the individual toothed tracks are properly aligned to ensure smooth gate movement.
- ▶ After fitting, the toothed tracks and the toothed wheel of the operator must be aligned to each other. Both the toothed tracks and the operator housing can be adjusted to do this.

Incorrectly fitted or poorly aligned toothed tracks may lead to unintentional reversing. It is essential that the specified dimensions are adhered to!

- ▶ Seal the housing to protect it from humidity and vermin (see **Figure 4.4**).

3.3 Connecting the mains lead

- ▶ See **Figure 4.5**

The mains is connected directly at the plug terminal to the transformer via the NYY underground cable. Follow the safety instructions in *section 2.5*.

3.4 Fitting the print bracket

- ▶ See **Figure 4.6**

1. Fasten the print bracket using the two screws loosened earlier, (D), as well as two additional screws from the scope of delivery.
2. Replace the connecting terminals.

3.5 Fitting the magnet bracket

- ▶ See **Figure 4.7**

1. Push the gate by hand into the *CLOSE* end-of-travel position.
2. Fully preassemble the magnet slide in the centre position.
3. Fit the toothed track clip so that the magnet is offset by approx. 20 mm from the reed contact in the circuit board bracket.

3.6 Locking the operator

- ▶ See **Figure 5**

The operator is engaged once locked.

- ▶ Turn the mechanism back to the lock position while slightly raising the motor.

3.7 Connecting additional components/accessories

- ▶ See the control print overview in **Figure 6**

ATTENTION

Damage to the electronics caused by external voltage

External voltage on the connecting terminals of the control will destroy the electronics.

- ▶ Do not apply any mains voltage (230/240 V AC) to the connecting terminals on the control.

The total consumed current may be **max. 500 mA** when connecting accessories at the following terminals:

- 24 V=
- Ext. radio
- SE3/LS
- SE1/SE2

3.7.1 Connecting an external radio receiver

- ▶ See **Figure 6.1**
- ▶ Connect the wires of the external radio receiver as follows:
 - terminal 20 (0 V)
 - terminal 21 (channel 1 signal)
 - terminal 5 (+24 V)
 - terminal 23 (channel 2 signal for partial opening). Only with a 2-channel receiver.

NOTE:

The aerial wire of external radio receivers should not come into contact with metal objects (nails, bracing, etc.). The best orientation to achieve an optimum range must be established by trial and error.

3.7.2 Connecting an external button*

- ▶ See **Figure 4.1**
- (*Accessory, not included as standard equipment!)
- One or more buttons with normally open contacts (volt-free), e.g. key switches, can be connected in parallel, max. lead length 10 m.

Impulse control

- ▶ First contact to terminal **21**
- ▶ Second contact to terminal **20**

Partial opening:

- ▶ First contact to terminal **23**
- ▶ Second contact to terminal **20**

NOTE:

If auxiliary voltage is needed for an external button, then a voltage of +24 V DC is available for this at terminal **5** (to terminal **20** = 0 V).

3.7.3 Connecting a cut-out to stop the operator (STOP or emergency-OFF circuit)

A cut-out with normally closed contacts (switching to 0 V or volt-free) is connected as follows (see **Figure 4.3**):

1. Remove the wire jumper inserted at the factory between terminal **12** and terminal **13**.
 - Terminal 12: STOP or emergency-OFF input
 - Terminal 13: 0 V, allows normal function of the operator
2. Connect the switching output or first contact to terminal **12** (STOP or emergency-OFF input).
3. Connect 0 V (ground) or the second contact to terminal **13** (0 V).

NOTE:

By opening the contact, any travel cycles in progress are immediately halted and permanently prevented.

3.7.4 Connecting a warning lamp*

- ▶ See **Figure 6.4**
- (*Accessory, not included as standard equipment!)
- A warning lamp or *CLOSE* limit switch reporting can be connected via the volt-free contacts on the *Option* connector. The voltage at the 24 V DC connector can be used for operation (e.g. warning signals prior to and during gate travel) with a 24 V lamp (max. 7 W).

NOTE:

A 230 V warning lamp must be directly supplied with power.

3.7.5 Connecting safety/protective devices

- ▶ See **Figures 6.5–6.7**
- Safety devices such as photocells/closing edge safety devices (SKS) or 8k2 resistance contact strips can be connected:

SE1	In the opening direction, safety device with testing or 8k2 resistance contact strip
SE2	In the closing direction, safety device with testing or 8k2 resistance contact strip
SE3	In the closing direction, photocell without testing or dynamic 2-wire photocell, e.g. as a through-traffic photocell

The functions selected for the 3 safety circuits are set via the DIL switches (see *section 5*).

Terminal assignment:

Terminal 20	0 V (power supply)
Terminal 18	Test signal
Terminals 71/72/73	Safety device signal
Terminal 5	+24 V (power supply)

NOTE:

Safety devices without a testing unit (e.g. static photocells) must be tested twice a year. They may only be used to protect property!

3.7.6 Connecting a universal adapter print UAP1*

- ▶ See **Figure 6.8**
- (*Accessory, not included as standard equipment!)
- Connection option for the universal adapter print UAP1.

4 Putting into Service

- ▶ Before initial start-up, check that all the connecting leads are correctly installed at the connecting terminals.
- ▶ Make sure that all DIL switches are set to the factory setting (OFF) (see **Figure 7**), the gate is half open and the operator engaged.

4.1 Preparation

Change the following DIL switches:

- ▶ **DIL switch 1:** Installation direction (see **Figure 7.1**)
 - To ON, if the gate closes towards the right.
 - To OFF, if the gate closes towards the left.
- ▶ **DIL switches 3-7:** Safety devices (see **Figures 9.6/9.7/9.8**)
 - Set according to the connected safety and protective devices (see *section 5.3 – 5.5*). These are, however, not active during set-up mode.

4.2 Teaching in the gate's end-of-travel positions

4.2.1 Recording the *CLOSE* end-of-travel position

- ▶ See **Figure 8.1a**
- The limit switch (reed contact) must be connected before teaching in the end-of-travel positions. The limit switch wires must be connected at the **REED** terminal.

The option relay has the same function as the red LED during set-up. The limit switch position can be viewed from afar with a lamp connected to it (see **Figure 4.4**).

Teaching in the CLOSE end-of-travel position:

1. Open the gate halfway.
2. Set **DIL switch 2** (set-up mode) to **ON**.
The green LED slowly flashes, the red LED remains lit.
3. Press print button **T** and keep it pressed.
The gate now travels in *CLOSE* direction at slow speed. The gate stops once the limit switch has been reached.
4. Immediately release print button **T**.
The red LED goes out.

The gate is now in the *CLOSE* end-of-travel position.

NOTE:

If the gate travels in the opening direction, **DIL switch 1** is in the wrong position and must be reset. Then repeat steps 1 to 4.

If the position of the gate does not correspond to the desired *CLOSE* position, a readjustment must be made.

Readjusting the CLOSE end-of-travel position:

1. Adjust the position of the magnet by moving the magnet slide.
2. Press print button **T** until the gate reaches the readjusted end-of-travel position and the red LED goes out.
3. Repeat steps 1 + 2 until the desired end-of-travel position has been reached.

4.2.2 Recording the OPEN end-of travel position

- ▶ See **Figure 8.1b**

Teaching in the OPEN end-of-travel position:

4. Press print button **T** and keep it pressed.
The gate now travels in *OPEN* direction at slow speed.
5. Release print button **T** once the required *OPEN* end-of-travel position is reached.
6. Press print button **P** to confirm this position.
The green LED flashes rapidly for 2 seconds to indicate that the *OPEN* end-of-travel position has been recorded.

4.2.3 Recording the partial opening end-of-travel position

- ▶ See **Figure 8.1c**

NOTE:

If press-and-hold operation has been set, it is not possible to record the *partial opening* end-of-travel position.

Teaching in the partial opening end-of-travel position:

1. Press print button **T** and keep it pressed to move the gate back towards the *CLOSE* position.
2. Release print button **T** once the desired *partial opening* end-of-travel position is reached.
3. Press print button **P** to confirm this position.
The green LED flashes slowly to indicate that the *partial opening* end-of-travel position has been recorded.

4.2.4 Completion of set-up mode

- ▶ After you have finished the teach-in procedure, set **DIL switch 2** back to **OFF**.
The green LED signals that forces must be taught in by flashing quickly.

The safety devices are active again.

4.2.5 Reference run

- ▶ See **Figure 8.2**

After teaching in the end-of-travel positions, the first cycle thereafter is always a reference cycle. During this reference cycle the option relay clocks and a connected warning light flashes.

Reference cycle to CLOSE end-of-travel position:

- ▶ Press print button **T** once.
The operator automatically moves into the *CLOSE* end-of-travel position.
- ▶ If press-and-hold operation has been set, press and hold print button **T** until the gate is in the *CLOSE* end-of-travel position.

NOTE:

Initial start-up is now finished if press-and-hold operation has been set (**DIL switch 16** to **ON**).

4.3 Learning the forces

Once the end-of-travel positions have been taught in and the reference cycle performed, the forces must be taught in during force learning runs. For this, three successive gate cycles must take place, during which none of the safety devices may be activated. Recording the forces takes place automatically by press-and-release operation in both directions. The green LED flashes throughout. This LED is steadily illuminated once the force learning runs have been completed (see **Figure 9.1**).

- ▶ **Both of the following procedures must be conducted three times.**

Force learning runs:

- ▶ Press print button **T** once.
The operator automatically moves into the *OPEN* end-of-travel position.
- ▶ Press print button **T** once.
The operator automatically moves into the *CLOSE* end-of-travel position.

4.3.1 Setting the force limit

 WARNING
<p>Danger of injury if force limit is too high</p> <p>If the force limit has been set too high, the gate will not stop on time when closing and may trap persons or objects.</p> <ul style="list-style-type: none"> ▶ Do not set a force limit that is too high.

NOTE:

Due to special fitting situations, it can, however, happen that the previously taught-in forces prove inadequate which can lead to undesired reversing. Readjust the forces in such cases.

The force limit of the gate system is set via a potentiometer that is labelled Force **F** on the control print (see **Figure 9.1**).

1. The increase in the force limit is a percentage increase in relation to the taught-in values where the setting of the potentiometer denotes the following force increase:

Full left	+ 0 % force
Centred	+15 % force
Full right	+75 % force

- The taught-in force setting must be checked using a suitable force measuring device to make sure that the values are permissible within the application scope of the European Standards EN 12453 and EN 12445 or the corresponding national regulations.

4.3.2 Operator speed

If the force measured with the force measuring device is still too high when the potentiometer is turned to full left, this can be changed by reducing the travel speed. (See **Figure 9.2**)

Adjusting the speed:

- Set **DIL switch 15** to **ON**.
- Perform three successive force learning runs (see *section 4.3*).
- Check again using the force measuring device.

4.3.3 Switching off the force limit

NOTE:

Not for use in countries with EU directives!

The force limit can be switched off by snipping through the **BR1** wire jumper on the control print.

If no safety devices are connected (**DIL switches 3–6** to **OFF**), the operator will only work in press-and-hold operation.

If 8k2 resistance contact strips are connected (**DIL switches 3–6** to **ON**), the operator will work in press-and-release operation without force limit.

Deactivating the force limit:

- Perform a factory reset (see *section 10*).
- Snip through the **BR1** wire jumper.
- Set **DIL switch 2** to **ON** and teach in the operator again (see *section 4.2*).

If the wire jumper is snipped through during set-up or during gate travel, this will not have any effect on the function.

Reactivating the force limit:

- Perform a factory reset (see *section 10*).
- Connect the **BR1** wire jumper.
- Set **DIL switch 2** to **ON** and teach in the operator again (see *section 4.2*).

4.4 Changing the starting point for slow speed when opening and closing

The slow speed length is automatically set to a basic value of approx. 500 mm before the end positions after the end positions have been taught in. The starting point can be reprogrammed from a minimum length of approx. 300 mm up to the entire gate length (see **Figure 9.3**).

Changing the starting points for slow speed deletes the already taught-in forces and they must be taught in again after the changes have been made.

Setting the positions for slow speed:

- The end-of-travel positions must be set and the gate is in the *CLOSE* end-of-travel position and **DIL switch 2** must be set to **OFF**.
- Set **DIL switch 12** to **ON**.
- Press print button **T**.
The gate will travel normally in press-and-release operation in the *OPEN* direction.
- When the gate passes the desired position for the start of slow speed, briefly press print button **P**.
The operator will move at slow speed for the remaining distance until in the *OPEN* end-of-travel position.

- Press print button **T** again.
The gate will again travel normally in press-and-release operation in the *CLOSE* direction.
- When the gate passes the desired position for the start of slow speed, briefly press print button **P**.
The operator will move at slow speed for the remaining distance until in the *CLOSE* end-of-travel position.
- Set **DIL switch 12** to **OFF**.

The slow speed starting point settings have now been completed. The green LED flashes to signal that the forces must be taught in again.

NOTE:

The starting points for slow speed can also be set to "overlap"; in this case, the entire gate movement is in slow speed.

4.5 Reversal limit

During operation of the gate in the *CLOSE* direction, it must differentiate between two conditions: whether the gate contacts the end stop (gate system stops) or an obstruction (gate reverses direction). The limit range can be adjusted as follows (see **Figure 9.4**).

Setting the reversal limit:

- Set **DIL switch 11** to **ON**.
The reversal limit can now be set step-by-step.
- Briefly press print button **P** to **decrease** the reversal limit. Briefly press print button **T** to **increase** the reversal limit. During adjustment, the green LED will indicate the following settings:

1x flashing up to	Minimum reversal limit, the green LED flashes once
10x flashing	Maximum reversal limit, the green LED flashes 10 times

- Set **DIL switch 11** back to **OFF** to store the set reversal limit.

4.6 Automatic timed closing

NOTE:

Automatic timed closing can only be activated if at least one safety device has been activated.

The hold-open phase can be set for operation with automatic timed closing (see **Figure 9.5**).

Setting the hold-open phase:

- Set **DIL switch 13** to **ON**.
The hold-open phase can now be set in increments.
- Briefly press print button **P** to **decrease** the hold-open phase. Briefly press print button **P** to **increase** the hold-open phase. During adjustment, the green LED will indicate the following settings:

1x flashing	30 second hold-open phase
2x flashing	60 second hold-open phase
3x flashing	90 second hold-open phase
4x flashing	120 second hold-open phase
5x flashing	180 second hold-open phase

- Set **DIL switch 11** back to **OFF** to store the set hold-open phase.

5 DIL Switch Functions

The control is programmed via the DIL switches. Before initial start-up, the DIL switches are in the factory settings, i.e. all switches are set to OFF. The DIL switch settings may only be changed under the following conditions:

- The operator is at rest.
- The warning or hold-open phase is not active.

The DIL switches must be set as described below in accordance with national regulations, the desired safety devices and the on-site circumstances.

5.1 DIL switch 1

Installation direction:

- ▶ See **Figure 7.1**

1 ON	Gate closes to the right (as viewed from the operator)
1 OFF 	Gate closes to the left (as viewed from the operator)

5.2 DIL switch 2

Set-up mode:

- ▶ See **Figures 8.1a–c**

The safety and protective devices are not active during set-up mode.



2 ON	<ul style="list-style-type: none"> • Teach-in gate travel • Delete gate data
2 OFF 	Normal mode

5.3 DIL switch 3/DIL switch 4

SE 1 safety device (opening):

- ▶ See **Figure 9.6**

The functions of the SE 1 are set with **DIL switch 3** in combination with **DIL switch 4**.

3 ON	Activation kit for closing edge safety device or photocell with testing
3 OFF 	<ul style="list-style-type: none"> • 8k2 resistance contact strip • Photocell from another manufacturer • No safety device (8k2 resistance between terminals 20/72, delivery status)
4 ON	Brief, immediate reversing in the CLOSE direction (for SKS)
4 OFF 	Brief, delayed reversing in the CLOSE direction (for photocell)



5.4 DIL switch 5/DIL switch 6

SE 2 safety device (closing):

- ▶ See **Figure 9.7**

The functions of the SE 2 are set with **DIL switch 5** in combination with **DIL switch 6**.

5 ON	Activation kit for closing edge safety device or photocell with testing
-------------	---

5 OFF 	<ul style="list-style-type: none"> • 8k2 resistance contact strip • Photocell from another manufacturer • No safety device (8k2 resistance between terminals 20/73, delivery status)
6 ON	Brief, immediate reversing in the OPEN direction (for SKS)
6 OFF 	Brief, delayed reversing in the OPEN direction (for photocell)

5.5 DIL switch 7

SE 3 protective device (closing):

- ▶ See **Figure 9.8**

Delayed reversing to *OPEN* end-of-travel position.

7 ON	Dynamic 2-wire photocell
7 OFF 	<ul style="list-style-type: none"> • Static photocell without testing • No safety device (wire jumper between terminals 20/71, delivery status)

5.6 DIL switch 8/DIL switch 9

The functions of the operator (automatic timed closing/warning phase) and the function of the option relay are set with **DIL switch 8** in combination with **DIL switch 9**.

- ▶ See **Figure 9.9a**

8 ON	9 ON	Operator Automatic timed closing, warning phase for each gate movement Option relay Relay clocks rapidly during the advance warning phase, normally during the travel phase and is OFF during the hold-open phase.
-------------	-------------	---



- ▶ See **Figure 9.9b**

8 OFF 	9 ON	Operator Automatic timed closing, warning phase only for automatic timed closing Option relay Relay clocks rapidly during the warning phase, normally during the travel phase and is OFF during the hold-open phase.
---	-------------	---

- ▶ See **Figure 9.9c**

8 ON	9 OFF 	Operator Warning phase for each gate movement without automatic timed closing Option relay Relay clocks rapidly during the warning phase, normally during the travel phase.
-------------	---	--

- ▶ See **Figure 9.9d**

8 OFF 	9 OFF 	Operator No special function Option relay Relay picks up in the <i>CLOSE</i> end-of-travel position.
---	---	---

NOTE:

Automatic timed closing is only possible from the determined end-of-travel positions (full or partial opening). Automatic timed closing is deactivated if it fails three times. The operator must be restarted with an impulse.

5.7 DIL switch 10

Effect of the SE 3 protective device as a through-traffic photocell with automatic timed closing

► See **Figure 9.10**

10 ON	The photocell is activated as a through-traffic photocell, after the photocell has been passed, the hold-open phase is reduced.
10 OFF 	The photocell is not activated as a through-traffic photocell. If, however, <i>automatic timed closing</i> is activated and the photocell interrupted after the hold-open phase has elapsed, the hold-open phase will be reset to the preset time.

5.8 DIL switch 11

Setting the reversal limits:

► See **Figure 9.4** and *section 4.5*

11 ON	Reversal limit set step-by-step
11 OFF 	Normal mode

5.9 DIL switch 12

Starting point for slow speed when opening and closing:

► See **Figure 9.3** and *section 4.4*

12 ON	Starting points are set for slow speed when opening and closing
12 OFF 	Normal mode

5.10 DIL switch 13

Setting the hold-open phase:

► See **Figure 9.5** and *section 4.6*

13 ON	Hold-open phase is set in increments
13 OFF 	Normal mode

5.11 DIL switch 14

Impulse behaviour during the hold-open phase:

The impulse behaviour during the hold-open phase can be set for operation with automatic timed closing.

14 ON	An impulse cancels the hold-open phase. The operator closes the gate after the warning phase has elapsed.
14 OFF 	An impulse increases the hold-open phase by the pre-set time.

5.12 DIL switch 15

Setting the speed:

► See **Figure 9.2** and *section 4.3.2*

15 ON	Slow mode (slow speed); (no SKS required)
15 OFF 	Normal mode (normal speed)

5.13 DIL switch 16

Setting the operating mode:

Press-and-hold operation can be set with **DIL switch 16**. The force limit is set to the maximum value.

16 ON	Press-and-hold operation <ul style="list-style-type: none"> • A permanent contact at terminals 20 + 21 moves the operator in the <i>OPEN</i> direction • A permanent contact at terminals 20 + 23 moves the operator in the <i>CLOSE</i> direction • The operator stops if the respective contact is interrupted
16 OFF 	Normal mode

NOTE:

Special functions are possible during press-and-hold operation in conjunction with a universal adapter print UAP 1.

6 Radio

 CAUTION
<p>Unwanted gate travel</p> <p>Unwanted gate travel may occur while teaching in the radio system.</p> <p>► Pay attention that no persons or objects are in the gate's travel range when teaching in the radio system.</p>

- After teaching-in or extending the radio system, perform a function check.
- Only use original components when extending the radio system.

6.1 Important information for using the hand transmitter

WARNING

Danger of injury during gate travel

Persons may be injured by gate travel if the hand transmitter is actuated.

- ▶ Make sure that the hand transmitter is kept away from children and may only be used by people who have been instructed on how the remote-control gate functions!
- ▶ If the gate has only one safety feature, only operate the hand transmitter if you are within sight of the gate!

ATTENTION

Functional impairment due to environmental influences

These conditions can impair function!

- ▶ Protect the hand transmitter from the following environmental conditions:
 - Moisture
 - Dust
 - Direct sunlight
 (permissible ambient temperature: -20°C to +60°C)

NOTE:

Local conditions may affect the range of the radio system. Moreover, when used at the same time, GSM-900 mobile phones can affect the range.

6.2 Radio Remote Control

6.2.1 External radio receiver

Plug-in the external radio receiver on the respective connector (see Figure 6.1). The function *impulse* (Open-Stop-Close-Stop) and the function *partial opening* can be programmed on the external radio receiver.

7 Operation

WARNING

Danger of crushing and shearing

Fingers or limbs may be crushed and severed if caught in the toothed track or between the gate and closing edge while the gate is in motion.

- ▶ Whenever the gate is moving, never touch the toothed track, toothed wheel, and the main or secondary closing edges.

WARNING

Danger of injury during gate travel

Persons or objects may be trapped while the gate is closing.

- ▶ Make sure that no persons or objects are in the gate's travel range.
- ▶ Make sure that children are not playing near the gate system.
- ▶ If the gate has only one safety feature, only operate the sliding gate operator if you are within sight of the gate's travel range.
- ▶ Before driving in or out of the gateway, always check that the gate has fully opened. Never drive or walk through gateways unless the gate has reached the OPEN end-of-travel position.



7.1 Instructing users

- ▶ All persons using the gate system must be shown how to operate it properly and safely.
- ▶ Demonstrate and test the mechanical release as well as the safety return.

7.2 Function check

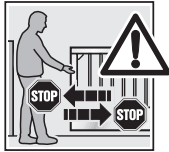

- ▶ To check the safety reversal, stop the gate with both hands while it is closing.
The gate system must stop and initiate the safety reversal. The gate system must also switch off and stop the gate while it is opening.

- ▶ In the event of a failure of the safety reversal, a specialist must be commissioned immediately for the inspection and repair work.

7.3 Normal mode:

During normal mode, the sliding gate operator only works according to the impulse sequence control (OPEN-STOP-CLOSE-STOP). It does not matter whether an external button, hand transmitter button or print button T has been actuated:

- ▶ To open and close fully, press the appropriate impulse generator for channel 1.
- ▶ To open and close partially, press the appropriate impulse generator for channel 2.

7.4 Behaviour during a power failure

To be able to open or close the sliding gate by hand during a power failure, it must be disengaged from the operator.

ATTENTION!

Damage due to moisture

- ▶ Protect the control from moisture when you open the operator housing.
1. Open the housing cover as shown in **Figure 3.1**.
 2. Release the operator by turning the locking mechanism. If necessary, press the motor and toothed wheel down by hand (see **Figure 13.1**).

7.5 Behaviour following a power failure

Once the power supply has been restored, the gate must be reengaged with the operator upstream from the limit switch.

- ▶ Slightly lift the motor while locking it (see **Figure 13.2**).

A new reference run is needed after a power failure. This is automatically performed if an impulse command is pending.

8 Inspection and Maintenance

The sliding gate operator is maintenance-free. For your own safety, however, we recommend having the **gate system checked by a specialist in accordance with the manufacturer's specifications**.

Inspection and repairs may only be carried out by a qualified person. Contact your supplier for this purpose. A visual inspection may be carried out by the operator.

- ▶ All safety and protective functions must be checked **monthly**.
- ▶ Check the 8k2 resistance contact strips for proper function **every six months**.
- ▶ If necessary, rectify any malfunctions and/or defects immediately.

9 Operation, Error and Warning Messages

- ▶ See LED GN and LED RT in **Figure 6**

9.1 LED GN

The green LED indicates the operating condition of the control:

Steady illumination Normal state, all end-of-travel positions and forces taught-in.
Fast flashing Force learning runs must be performed.
Slow flashing Set-up mode – end-of-travel setting
When setting the reversal limits Flashing frequency is proportional to the selected reversal limit <ul style="list-style-type: none"> • Minimum reversal limit: The green LED flashes 1x • Maximum reversal limit: The green LED flashes 10x
When setting the hold-open phase Flashing frequency depends on the set time <ul style="list-style-type: none"> • Minimum hold-open phase: LED flashes 1x • Maximum hold-open phase: LED flashes 5x

9.2 LED RT

The red LED indicates:

In set-up mode <ul style="list-style-type: none"> • Limit switch actuated = LED is off • Limit switch not actuated = LED is on
Display of the button inputs, radio <ul style="list-style-type: none"> • Actuated = LED is on • Not actuated = LED is off
In normal mode Flashing code as an error/diagnosis display

9.3 Error/diagnosis display

The red LED RT helps to easily identify causes when operation does not go according to plan.

NOTE:

If normal operation of the sliding gate operator with the radio receiver or the T button is otherwise possible, a short circuit in the external button's connecting lead or in the button itself can be recognised through the behaviour described here.

<p>Display flashes 2x</p> <p>Error/warning Safety/protective device has responded</p> <p>Possible cause</p> <ul style="list-style-type: none"> • Safety/protective device has been actuated • Safety/protective device defective • Without SE1, 8k2 resistance between terminal 20 and 72 missing • Without SE2, 8k2 resistance between terminal 20 and 73 missing • Without SE3, wire jumper between terminal 20 and 71 missing <p>Remedy</p> <ul style="list-style-type: none"> • Check safety/protective device • Check whether the appropriate resistance/wire jumpers are present without the connected safety/protective device
<p>Display flashes 3x</p> <p>Error/warning Force limit in <i>CLOSE</i> direction</p> <p>Possible cause Obstruction in gate area</p> <p>Remedy Remove obstruction; check forces, increase if necessary</p>
<p>Display flashes 4x</p> <p>Error/warning Hold or static current circuit is open, operator at a standstill</p> <p>Possible cause</p> <ul style="list-style-type: none"> • Normally closed contact at terminal 12/13 is open • Electric circuit interrupted <p>Remedy</p> <ul style="list-style-type: none"> • Close contact • Check electric circuit
<p>Display flashes 5x</p> <p>Error/warning Force limit in <i>OPEN</i> direction</p> <p>Possible cause Obstruction in gate area</p> <p>Remedy Remove obstruction; check forces, increase if necessary</p>
<p>Display flashes 6x</p> <p>Error/warning System error</p> <p>Possible cause Internal error</p> <p>Remedy Perform a factory reset (see <i>section 10</i>) and teach in the control again or exchange it, if necessary</p>

<p>Display flashes 7x</p> <p>Error/warning Peak force</p> <p>Possible cause</p> <ul style="list-style-type: none"> • Motor blocked • Force cut-out has not responded <p>Remedy Check the motor for seizure</p>
--

9.4 Error acknowledgement

If an error occurs, this can be acknowledged, provided the error is no longer present.

- ▶ On pressing the internal or external impulse generator, the error is deleted and the gate travels in the corresponding direction.

10 Factory Reset

Resetting the control (taught-in end-of-travel positions, forces) to the factory settings:

1. Set **DIL switch 2** to **ON**.
2. Immediately press print button **P** briefly.
3. When the red LED flashes rapidly, **DIL switch 2** must be quickly set to **OFF**.

The control system has now been reset to the factory setting.

11 Dismantling and Disposal

Have a specialist dismantle the sliding gate operator in the reverse order of these fitting instructions and dispose of it properly.

12 Optional Accessories

Optional accessories are not included in the scope of delivery. Loading of the operator by all electrical accessories: max. 100 mA.

The following accessories, among others, are available:

- External radio receivers
- External impulse buttons, e.g. key switch
- External code and transponder switches
- One-way photocells
- Warning lamps/warning lights
- Photocell expanders
- Universal adapter prints UAP 1
- Emergency batteries
- Further accessories available on request

13 Warranty Conditions

Warranty

We shall be exempt from our warranty obligations and product liability in the event that the customer carries out his own structural alterations or undertakes improper installation work or arranges for same to be carried out by others without our prior approval and contrary to the fitting guidelines we have provided. Moreover, we shall accept no responsibility for the inadvertent or negligent use of the operator or improper maintenance of the gate and the accessories nor for a non-authorized method of fitting the gate. Batteries are also not covered by the warranty.

Warranty period

In addition to the statutory warranty provided by the dealer in the sales contract, we grant the following warranty for parts from the date of purchase:

- 24 months for the operator mechanics, motor and motor control
- 24 months on radio equipment, impulse generator, accessories and special systems

There is no warranty on consumables (e.g. fuses, batteries, lamps). Claims made under the warranty do not extend the warranty period. For replacement parts and repairs the warranty period is six months or at least the remainder of the warranty period.

Prerequisites

A claim under this warranty is only valid for the country in which the equipment was bought. The product must have been purchased through our authorised distribution channels. A claim under this warranty exists only for damage to the object of the contract itself. Reimbursement of expenditure for dismantling and fitting, testing of corresponding parts, as well as demands for lost profits and compensation for damages, are excluded from the warranty. The receipt of purchase substantiates your right to claim under the warranty.

Performance

For the duration of the warranty we shall eliminate any product defects that are proven to be attributable to a material or manufacturing fault. We pledge to replace free of charge and at our discretion the defective goods with non-defective goods, to carry out repairs, or to grant a price reduction.

Damages caused by the following are excluded:











- improper fitting and connection
- improper initial start-up and operation
- external factors such as fire, water, abnormal environmental conditions
- mechanical damage caused by accidents, falls, impacts
- negligent or intentional destruction
- normal wear or deficient maintenance
- repairs conducted by unqualified persons
- use of non-original parts
- removal or defacing of the data plate

Replaced parts become our property.

14 Technical Data

Max. gate width:	Depending on operator type: 6,000 mm/8,000 mm/10,000 mm
Max. gate height:	Depending on operator type: 2,000 mm/3,000 mm
Max. gate weight:	Depending on operator type: 300 kg/500 kg/800 kg
Rated load:	See data plate
Max. pull and push force:	See data plate
Operator housing:	Diecast zinc and weather-resistant plastic
Mains voltage:	Rated voltage 230 V/50 Hz Max. power input 0.15 kW
Control:	Microprocessor control system, programmable via 16 DIL switches, control voltage 24 V DC
Operating mode:	S2, short-time duty 4 minutes
Temperature range:	-20°C to +60°C
Travel/force limit:	Electronic
Automatic safety cut-out:	Force limit for both operational directions, self-programming and testing
Hold-open phase:	<ul style="list-style-type: none"> • Adjustable between 30 - 180 seconds (photocell required) • 5 seconds (shorter hold-open phase with through-traffic photocell)
Motor:	24 V DC motor and worm gears, protection category IP 44

15 Overview of DIL Switch Functions

DIL 1	Installation direction			
ON	Gate closes to the right (as viewed from the operator)			
OFF	Gate closes to the left (as viewed from the operator)			
DIL 2	Set-up mode			
ON	Set-up mode (limit switch and OPEN end-of-travel position)/delete gate data (reset)			
OFF	Normal mode in press-and-release operation			
DIL 3	Type of SE1 safety device (connection tml. 72) when opening			
ON	Safety device with testing (SKS activating kit or photocell)			
OFF	8k2 resistance contact strip, photocell from another manufacturer or none (8k2 resistance betw. tml. 72 and 20)			
DIL 4	Effect of SE1 safety device (connection tml. 72) when opening			
ON	SE1 activation triggers brief, immediate reversing (for SKS)			
OFF	SE1 activation triggers brief, delayed reversing (for photocell)			
DIL 5	Type of SE2 safety device (connection tml. 73) when closing			
ON	Safety device with testing (SKS activating kit or photocell)			
OFF	8k2 resistance contact strip, photocell from another manufacturer or none (8k2 resistance betw. tml. 73 and 20)			
DIL 6	Effect of SE2 safety device (connection tml. 73) when closing			
ON	SE2 activation triggers brief, immediate reversing (for SKS)			
OFF	SE2 activation triggers brief, delayed reversing (for photocell)			
DIL 7	Type and effect of SE3 protective device (connection tml. 71) when closing			
ON	SE3 protective device is a dynamic 2-wire photocell			
OFF	SE3 protective device is a non-tested, static photocell			
DIL 8	DIL 9	Operator function (automatic timed closing)	Option relay function	
ON	ON	Automatic timed closing, warning phase for each gate movement	Clocks rapidly during advance warning phase, normally during travel phase, is OFF during hold-open phase	
OFF	ON	Automatic timed closing, warning phase only for automatic timed closing	Clocks rapidly during advance warning phase, normally during travel phase, is OFF during hold-open phase	
ON	OFF	Warning phase for each gate movement without automatic timed closing	Clocks rapidly during advance warning phase, normally during travel phase	
OFF	OFF	No special function	Picks up in the CLOSE end-of-travel position	
DIL 10	Through-traffic photocell with automatic timed closing			
ON	SE3 protective device activated as through-traffic photocell			
OFF	SE3 protective device not activated as through-traffic photocell			
DIL 11	Set reversal limit			
ON	Reversal limit set step-by-step			
OFF	Normal mode			
DIL 12	Setting the slow speed starting point for opening and closing			
ON	Starting points for slow speed when opening and closing			
OFF	Normal mode			

DIL 13 Setting the hold-open phase		
ON	Hold-open phase is set in increments	
OFF	Normal mode	

DIL 14 Impulse behaviour during the hold-open phase		
ON	Impulse cancels the hold-open phase	
OFF	Impulse extends the hold-open phase by the pre-set value	

DIL 15 Setting the speed		
ON	Slow mode (slow speed) (no SKS required)	
OFF	Normal mode (normal speed)	

DIL 16 Setting the operating mode		
ON	Press-and-hold operation	
OFF	Normal mode	

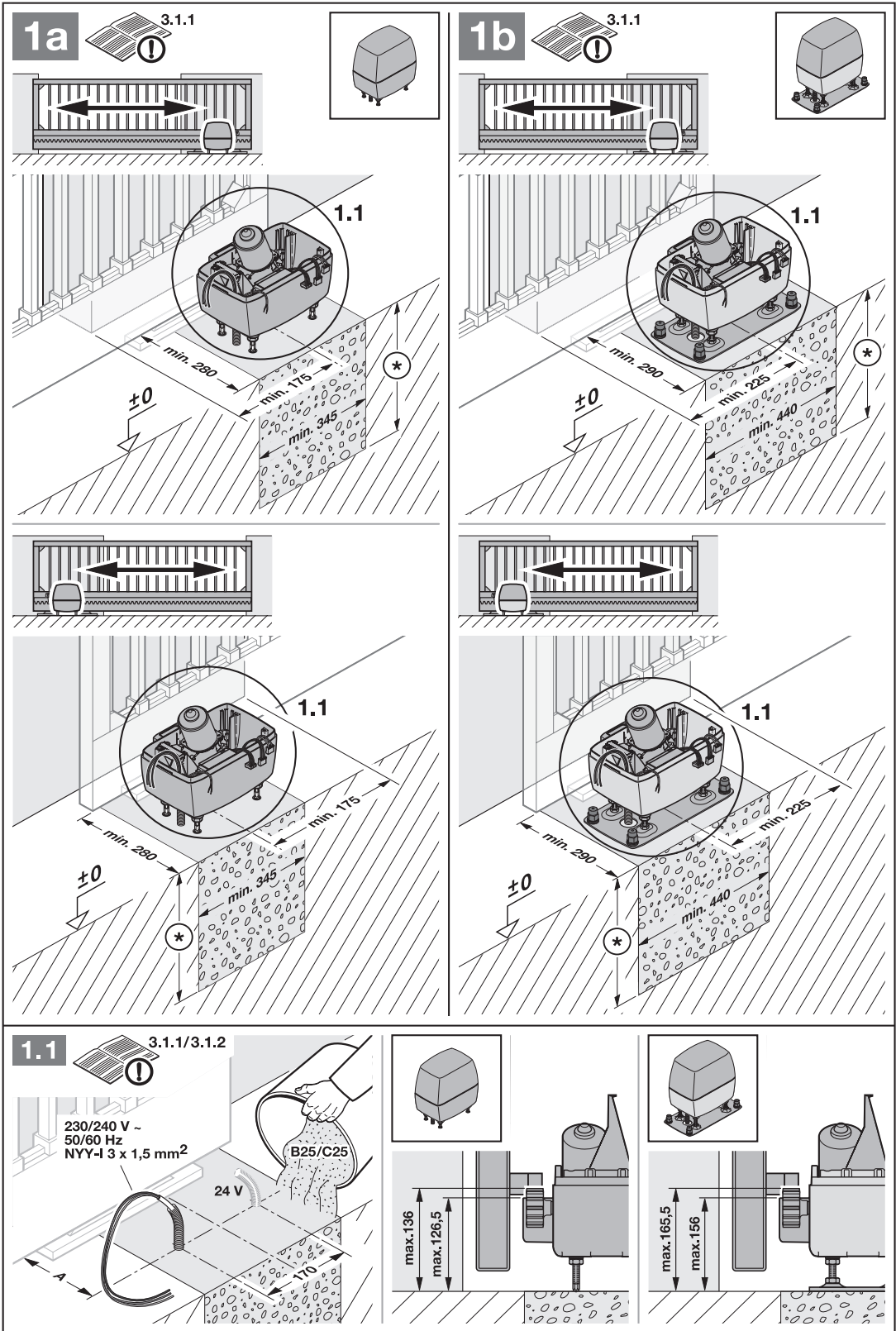

1c

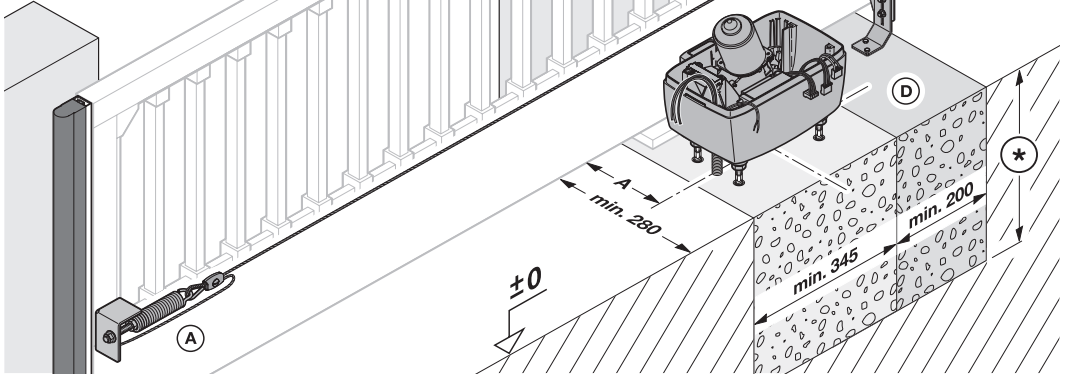
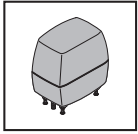
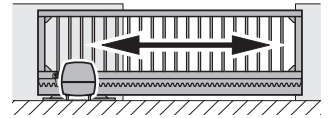
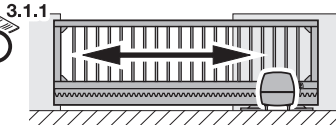

1c.1

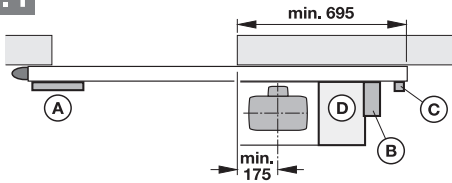

1c.5

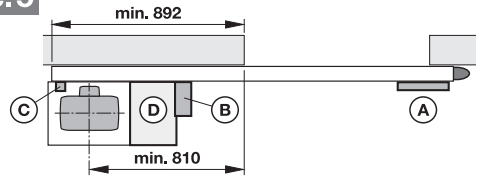

1c.2

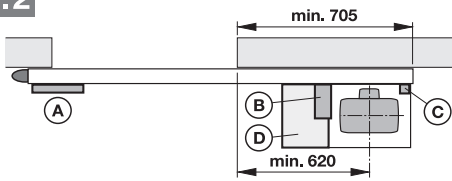

1c.6

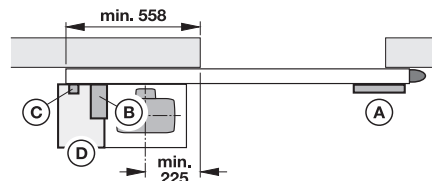

1c.3

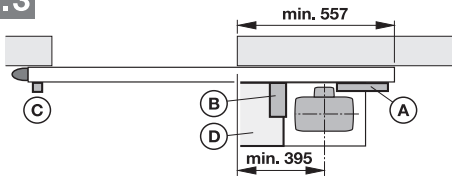

1c.7

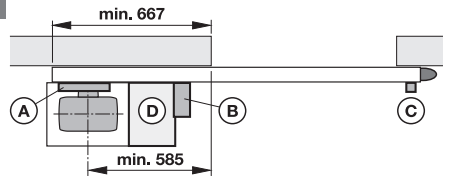

1c.4

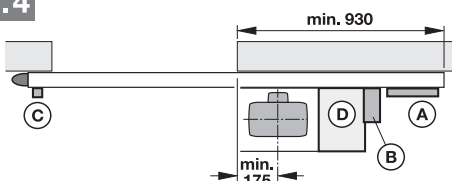

1c.8

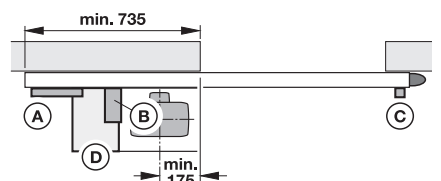

1d

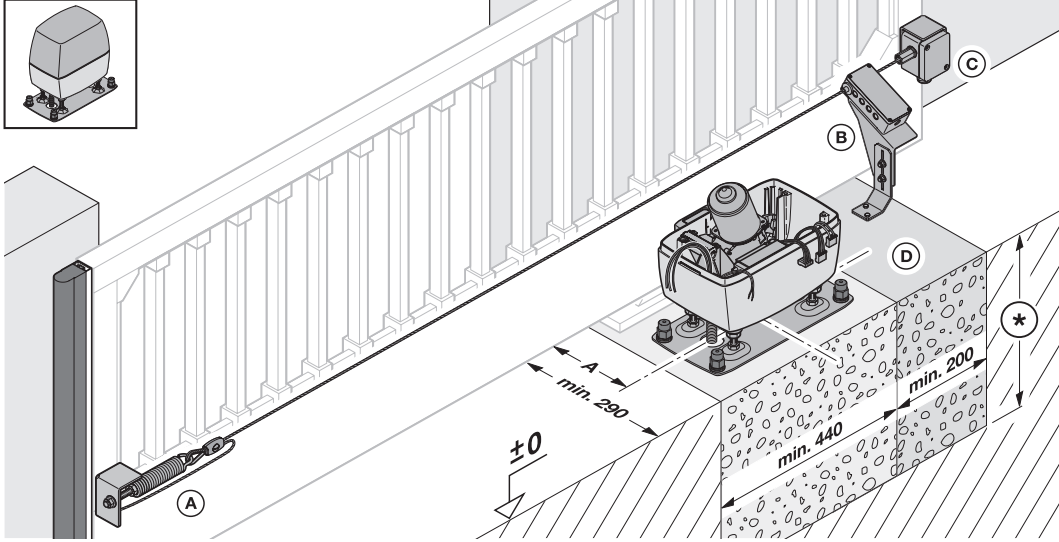
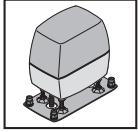
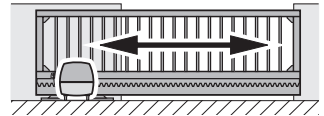
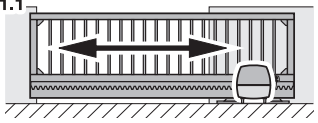

1d.1

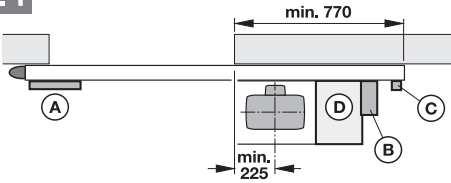

1d.5

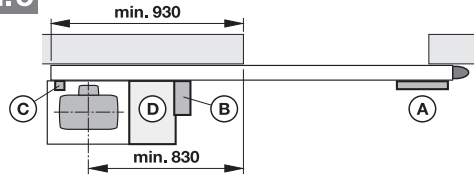

1d.2

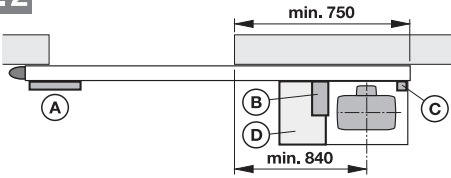

1d.6

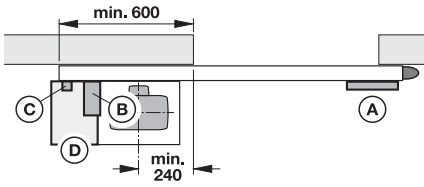

1d.3

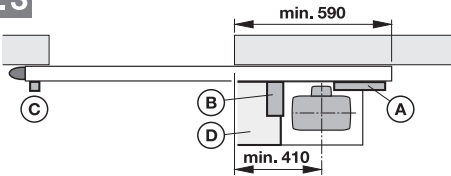

1d.7

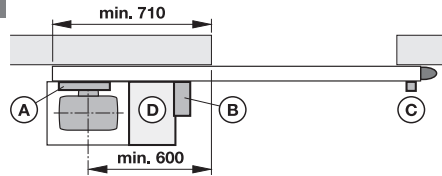

1d.4

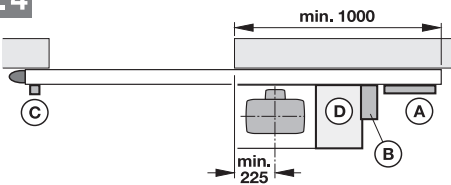

1d.8

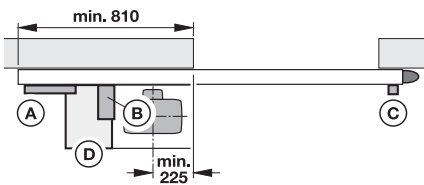

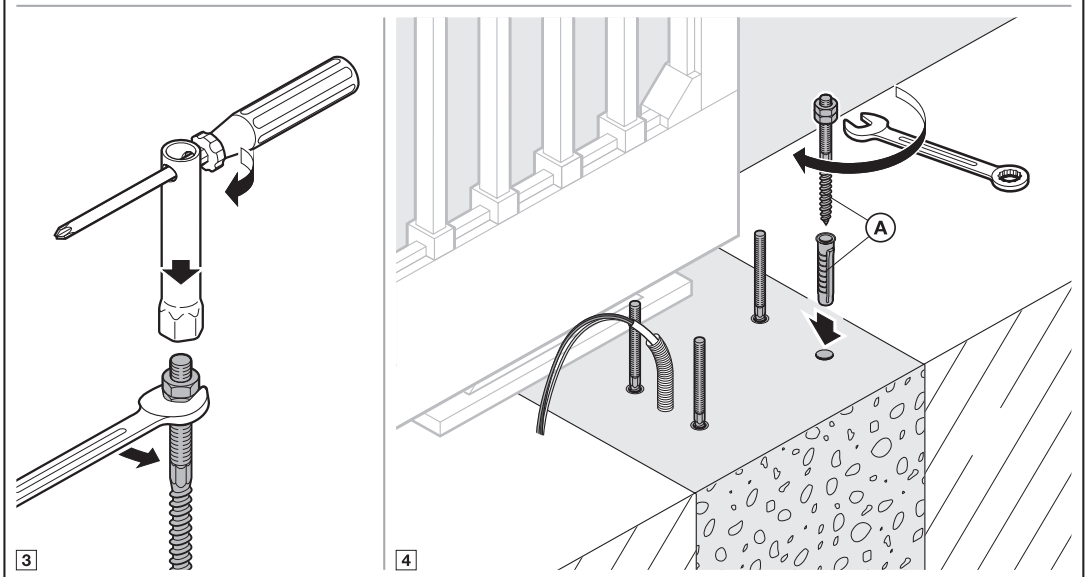
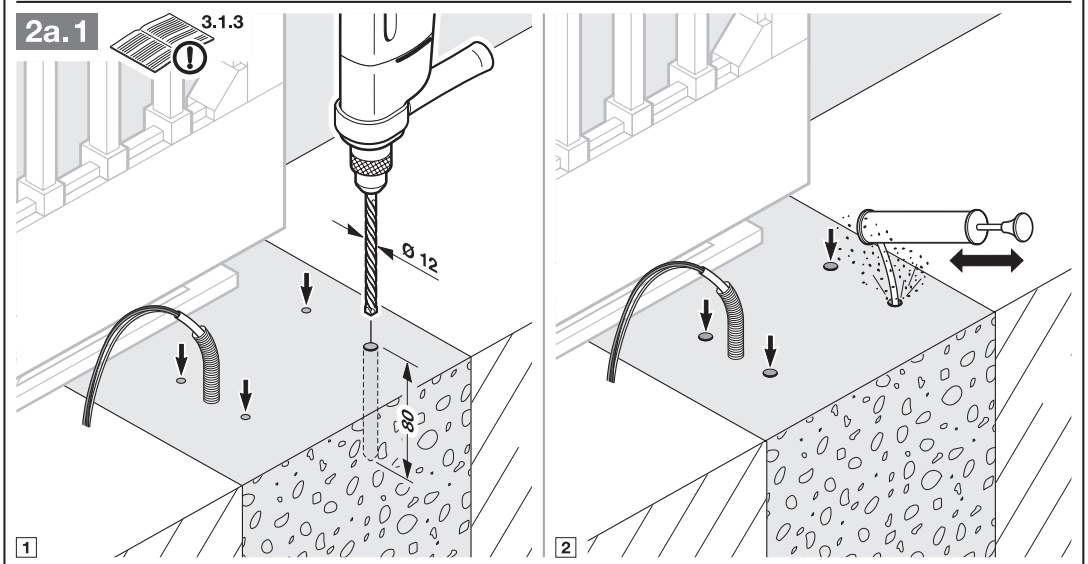
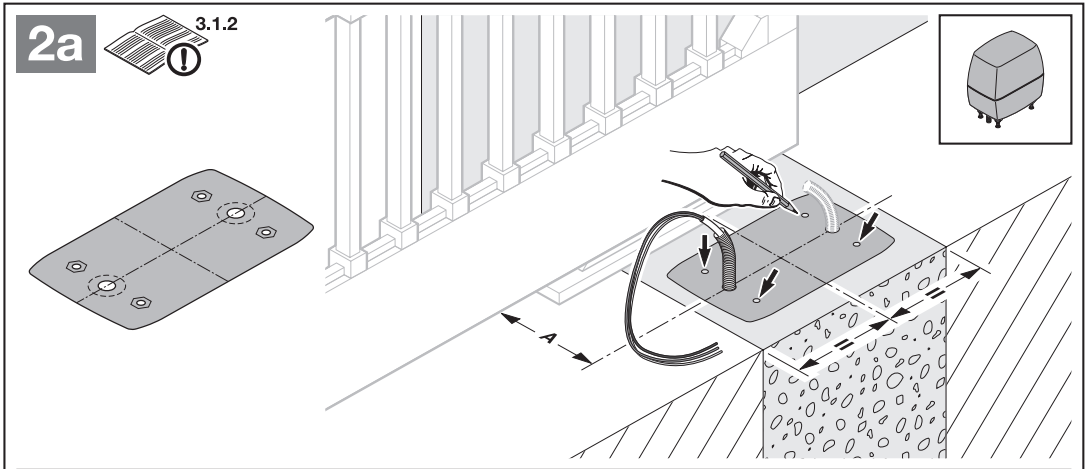

2b

3.1.2

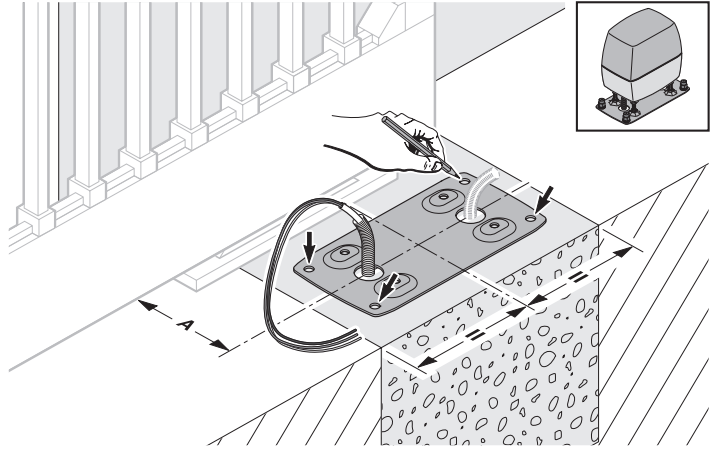
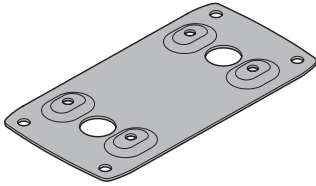

2a.1

3.1.3

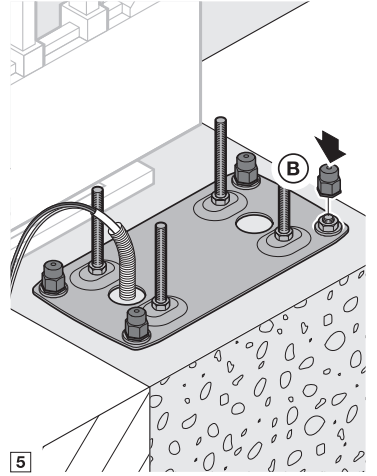
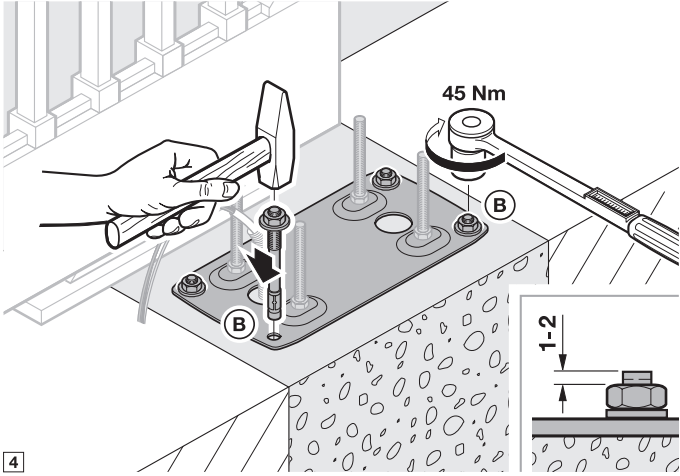
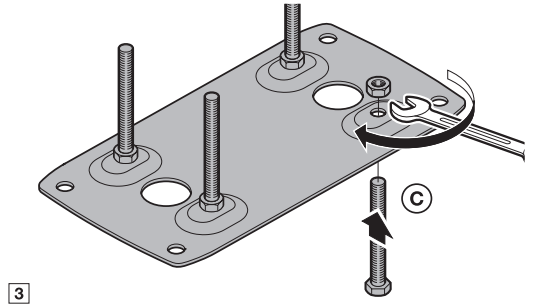
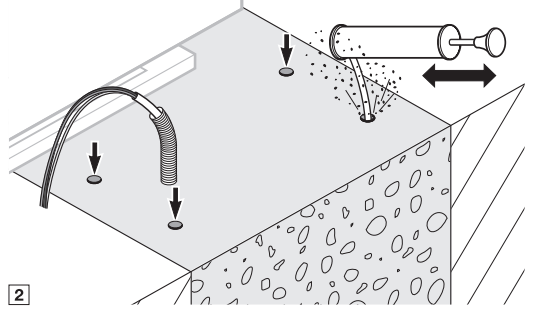
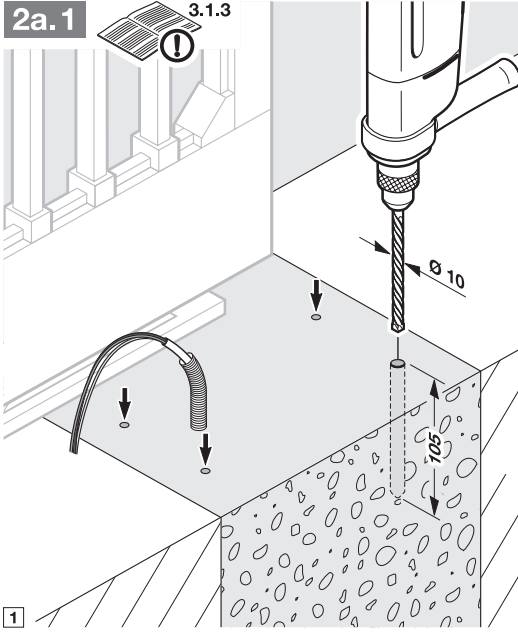

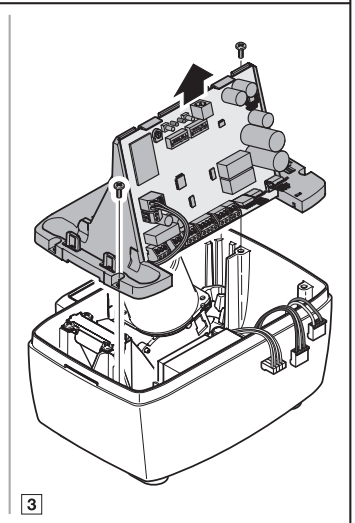
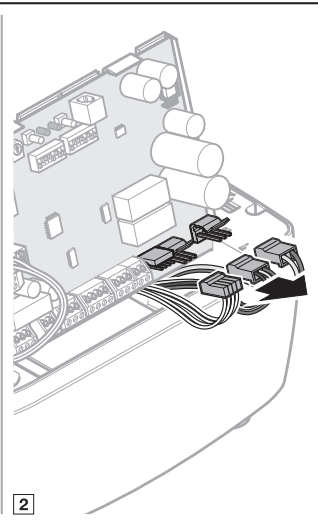
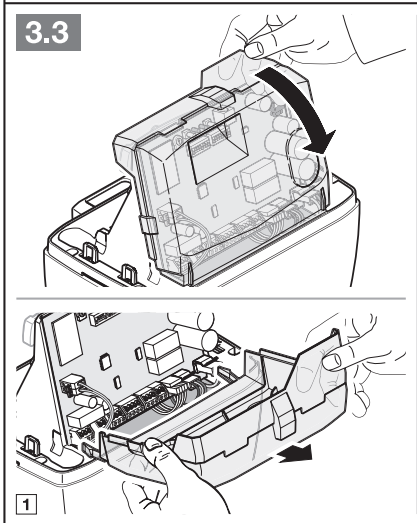
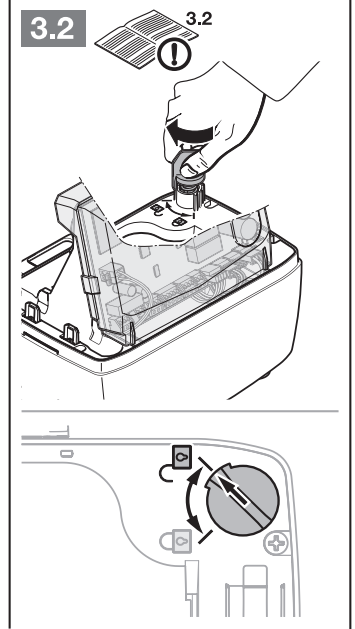
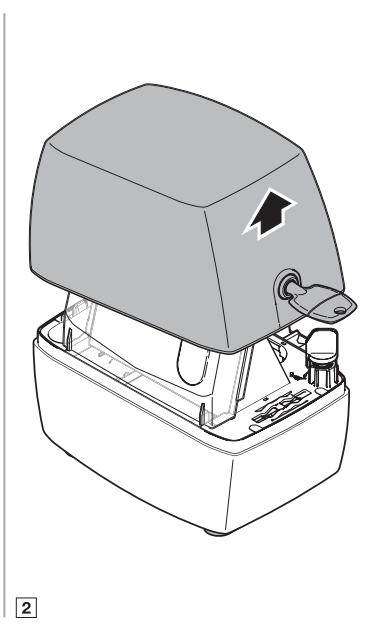
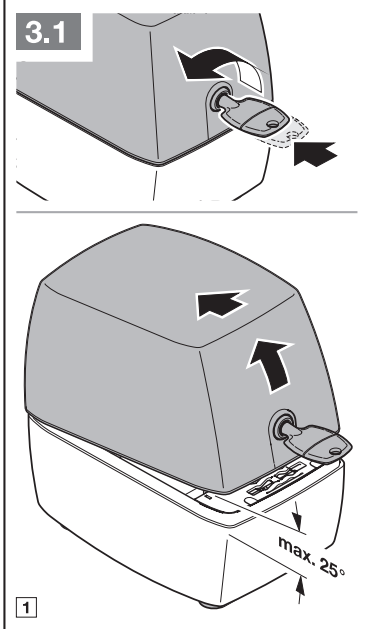
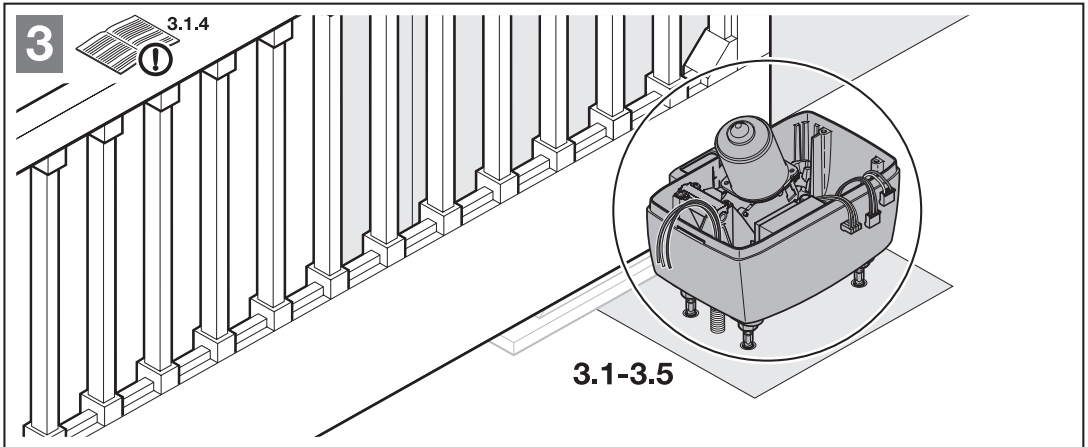

3.4

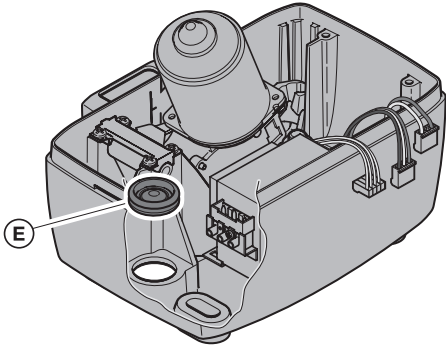

1

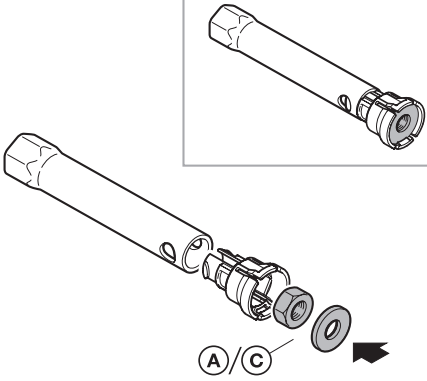

2

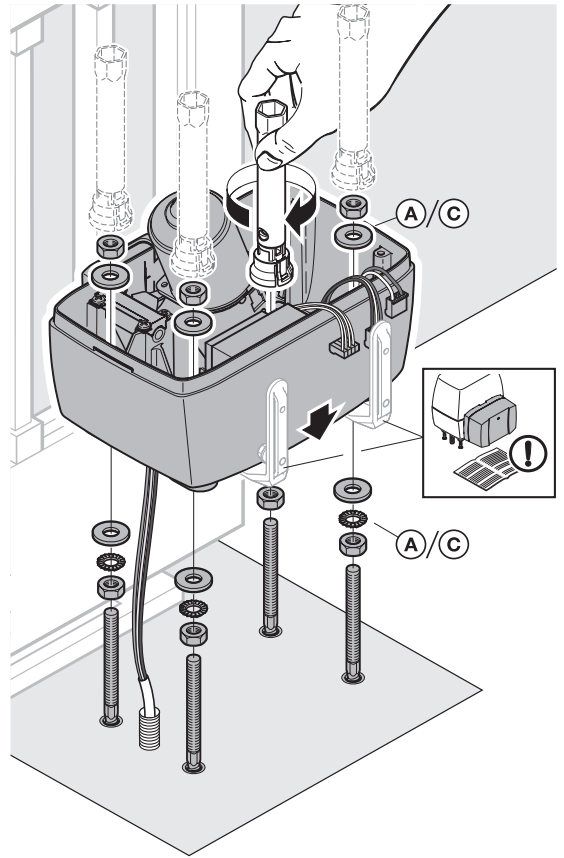

3

3.5

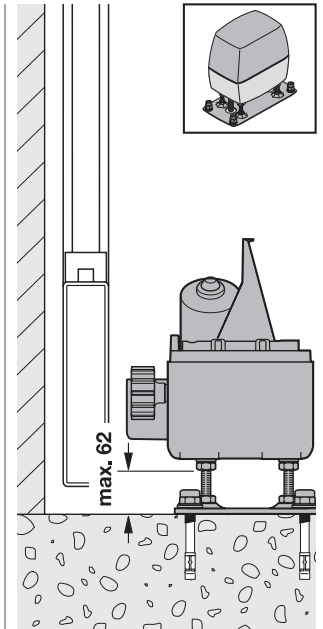
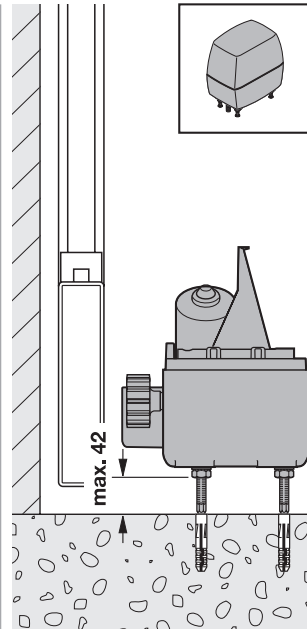
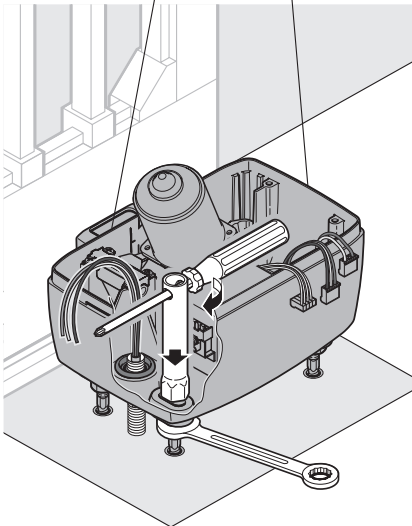

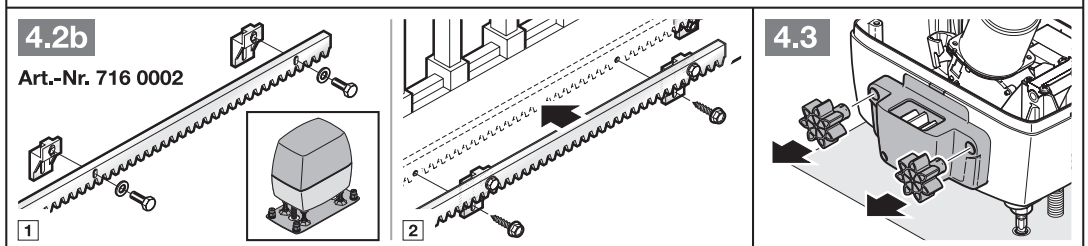
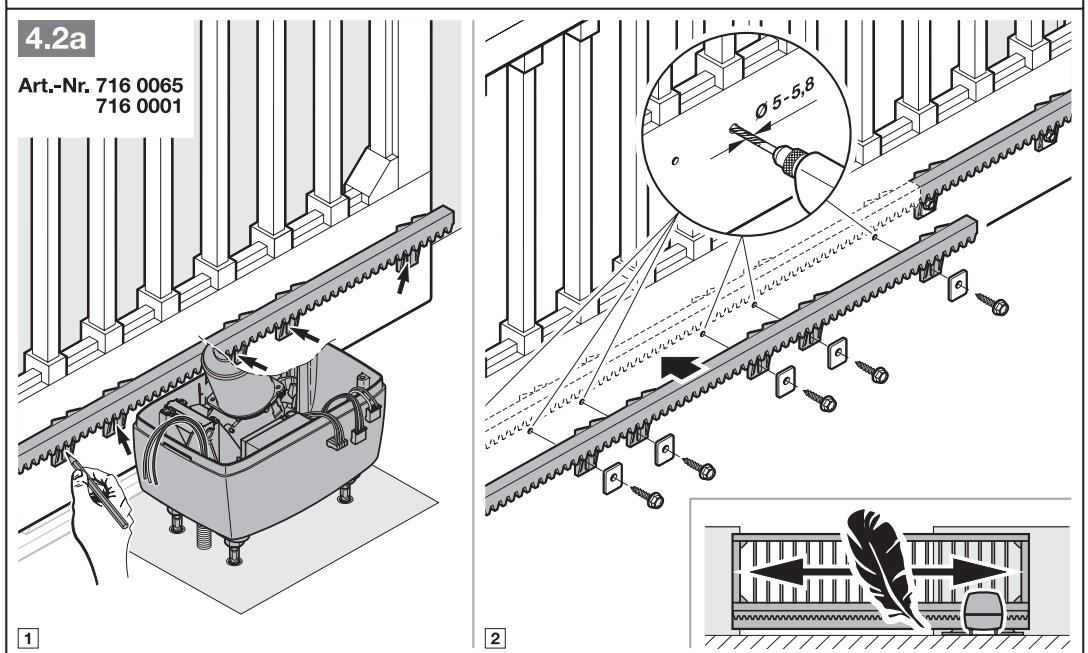
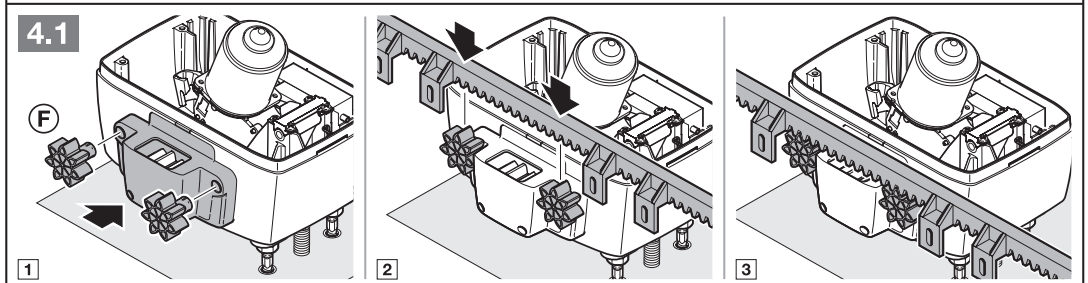
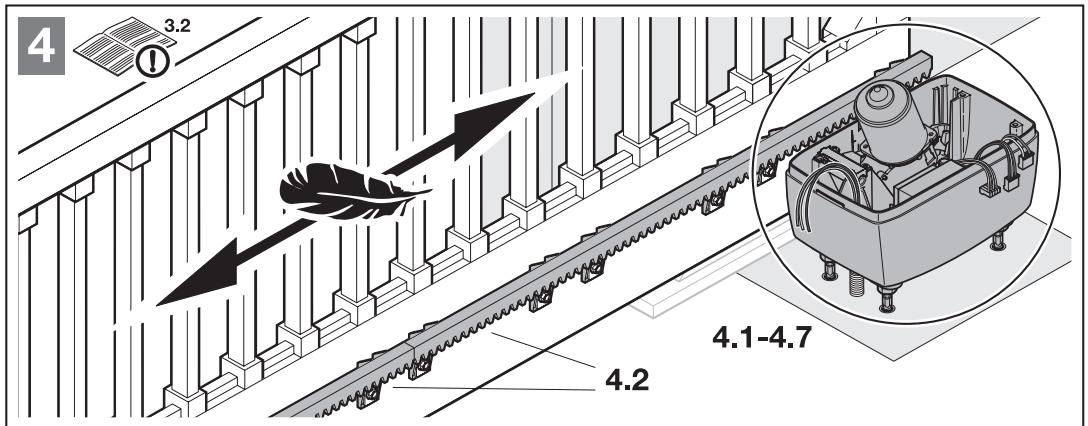

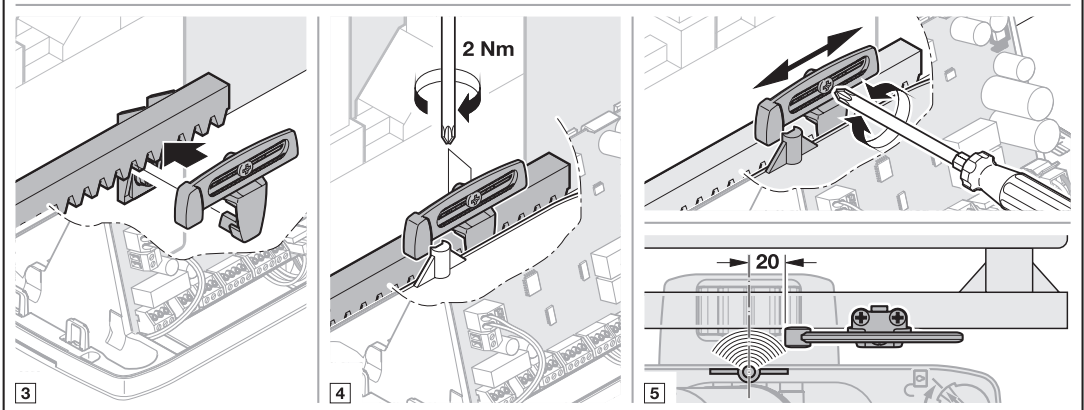
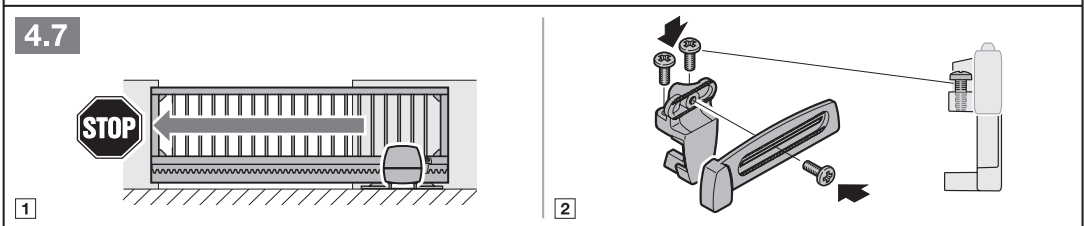
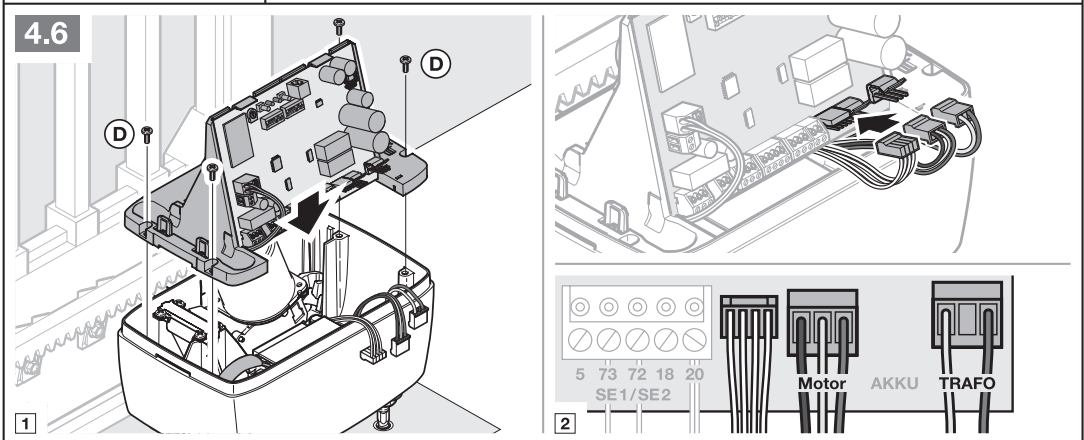
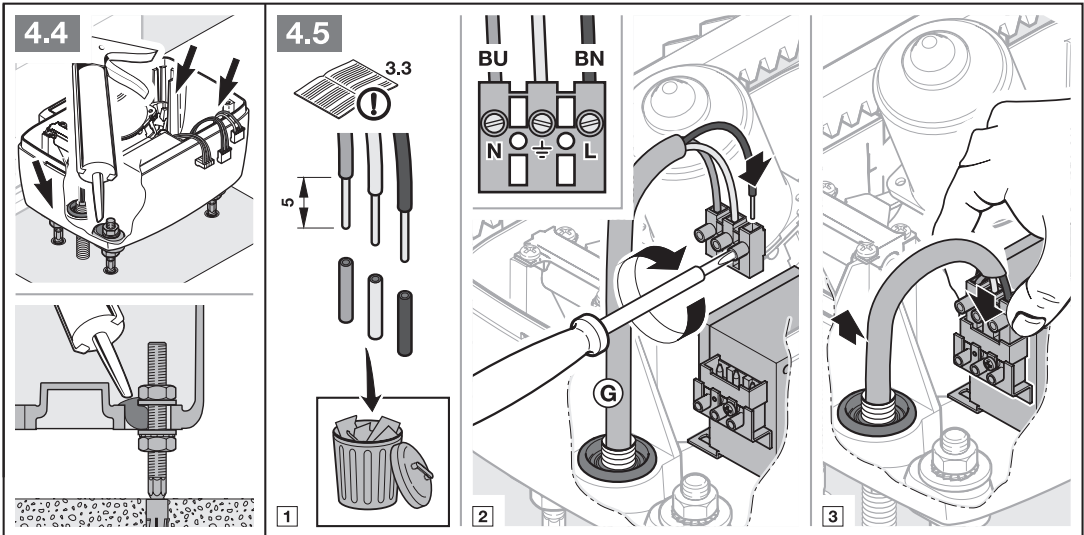

6.1

3.7.1/6.2.1

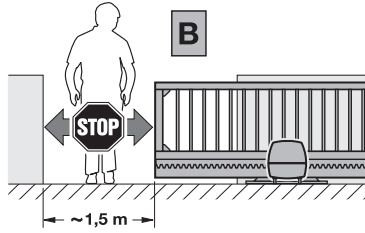
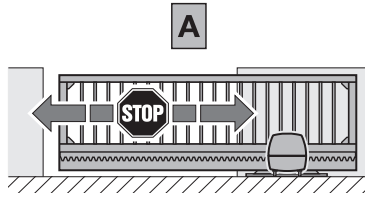
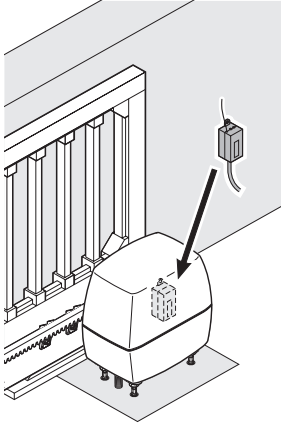

A

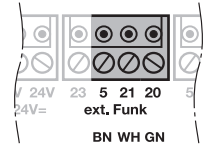

B

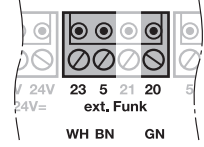

A+B

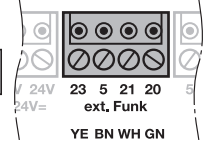

6.2

3.7.2

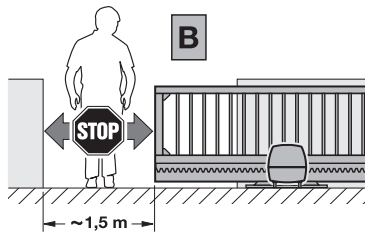
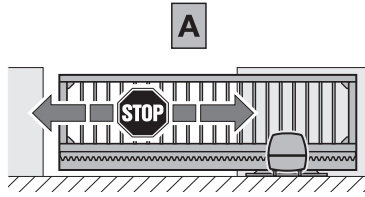
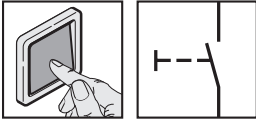

A

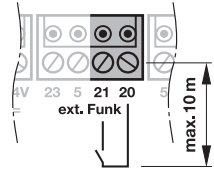

B

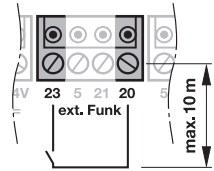

A+B

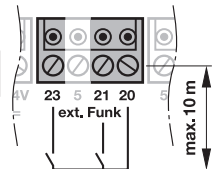

6.3

3.7.3

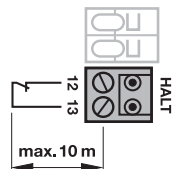
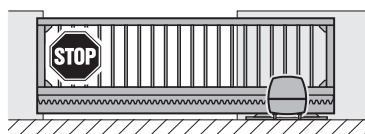

6.4

3.7.4/4.2.1

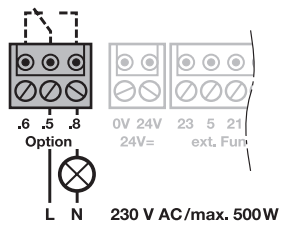
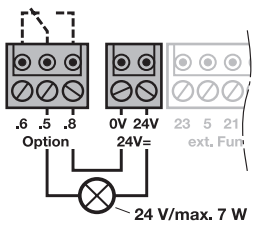
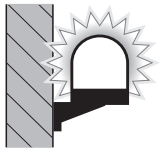

6.5a

3.7.5

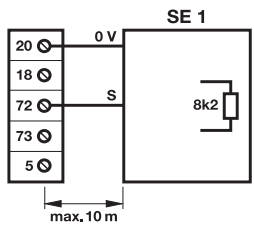
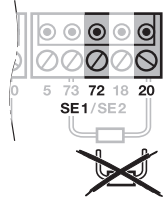
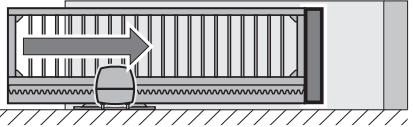

6.5c

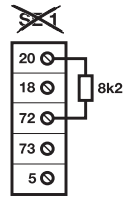

6.5b

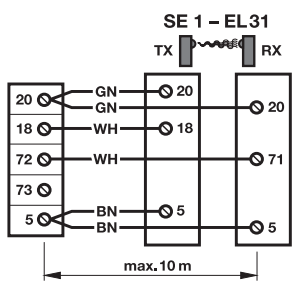
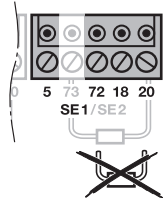
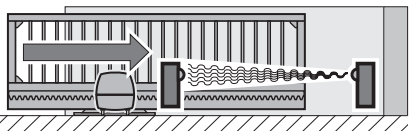

6.6a

3.7.5

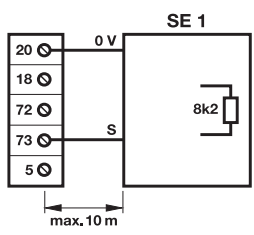
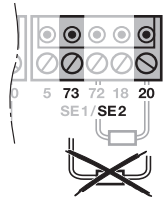
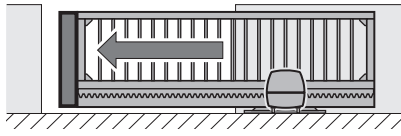

6.6c

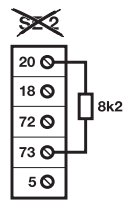

6.6b

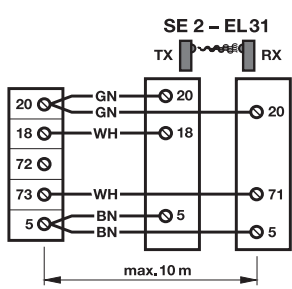
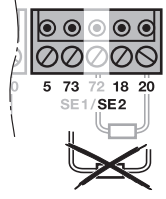
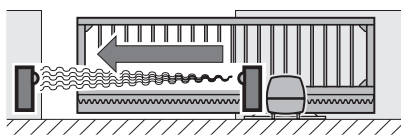

6.7a

3.7.5

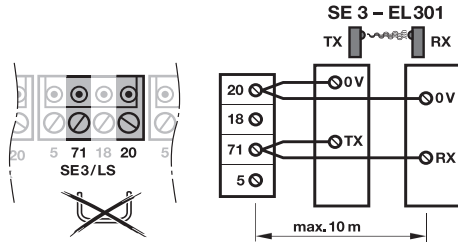
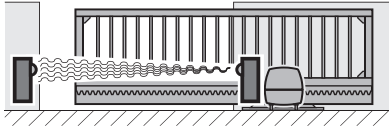

6.7b

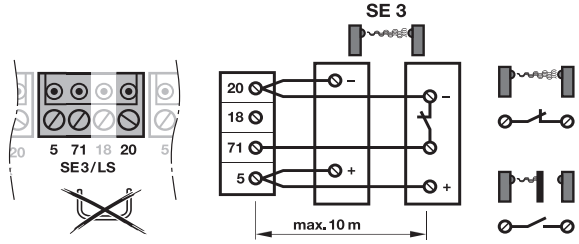
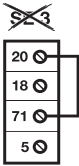

6.8

3.7.6

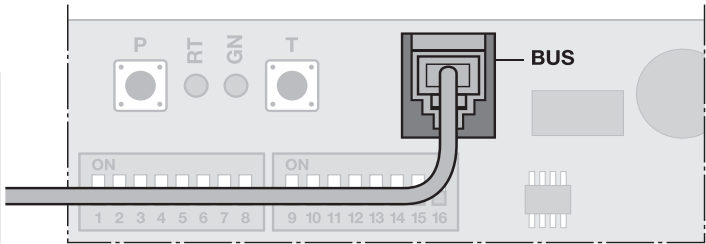
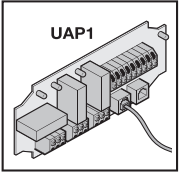

7

4

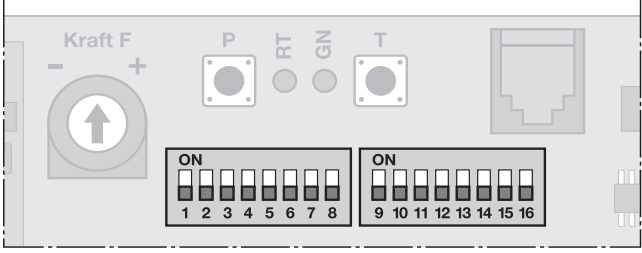

7.1

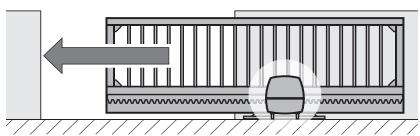
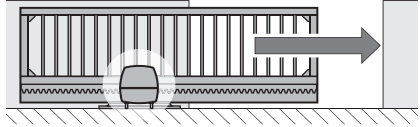

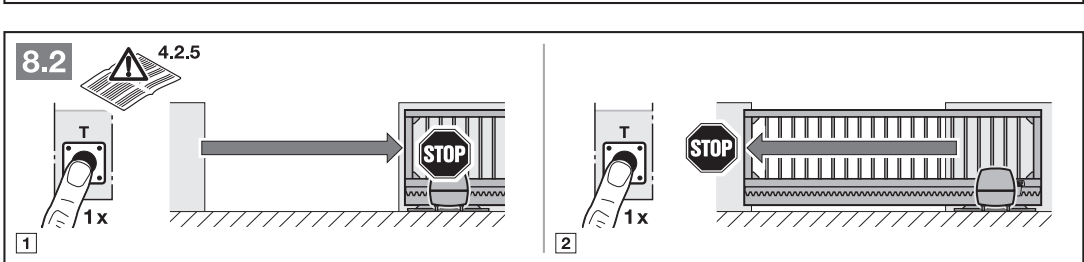
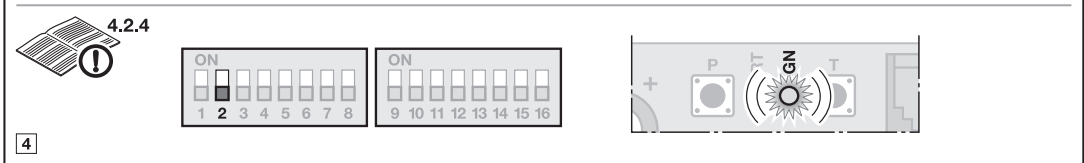
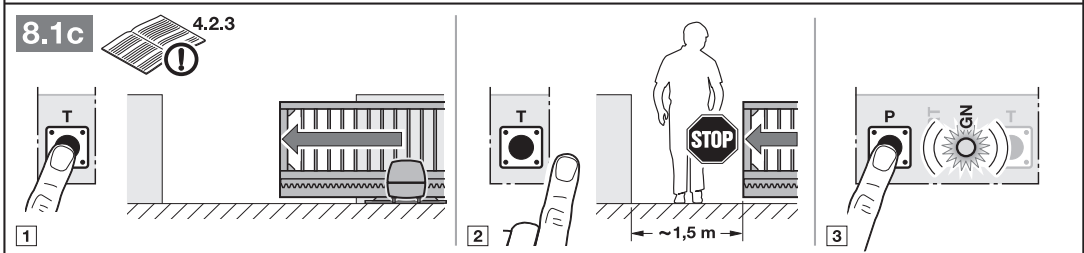
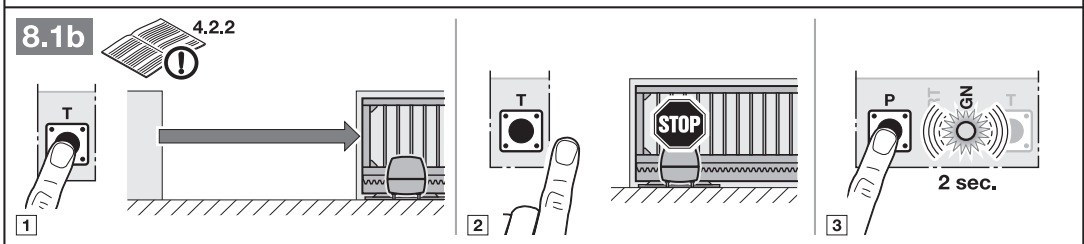
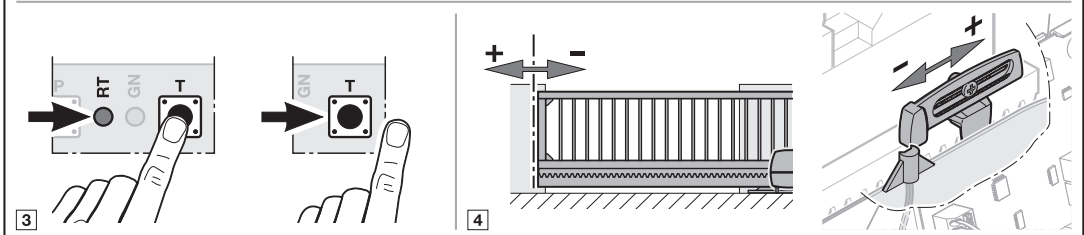
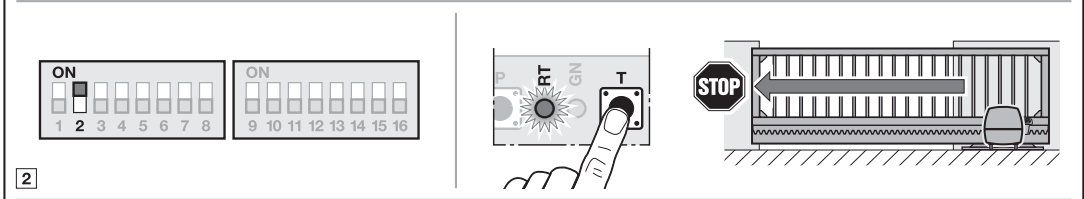
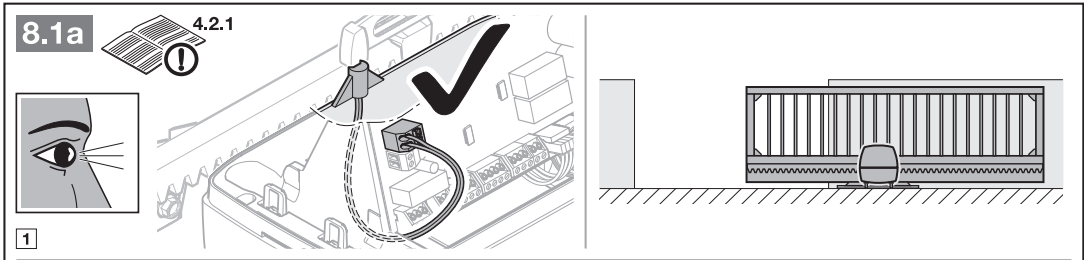

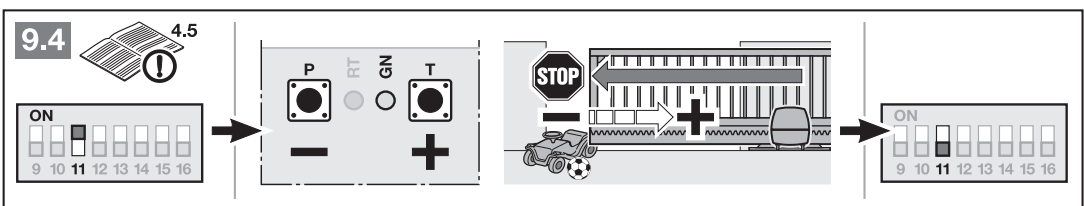
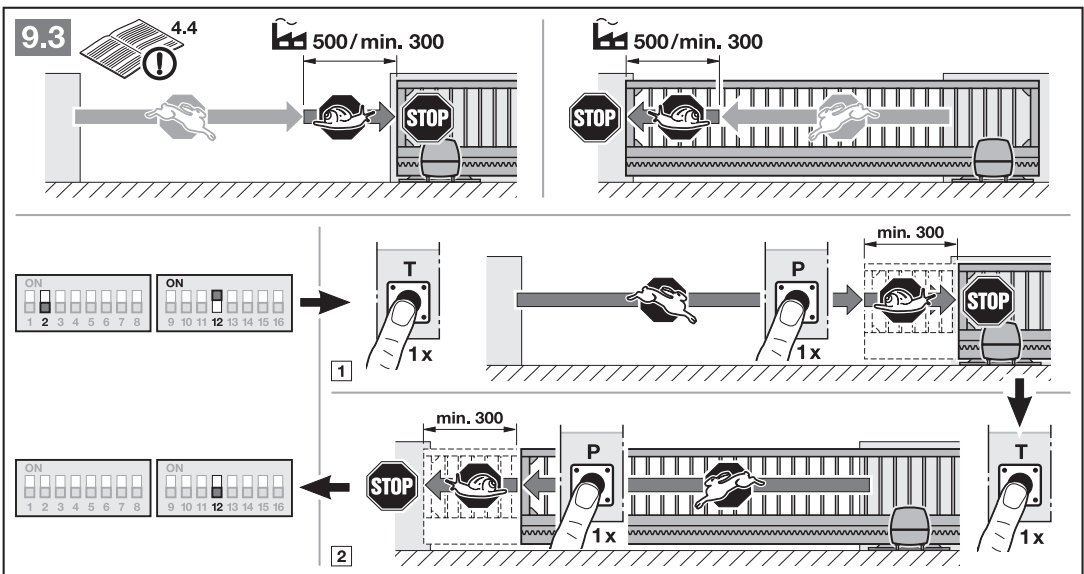
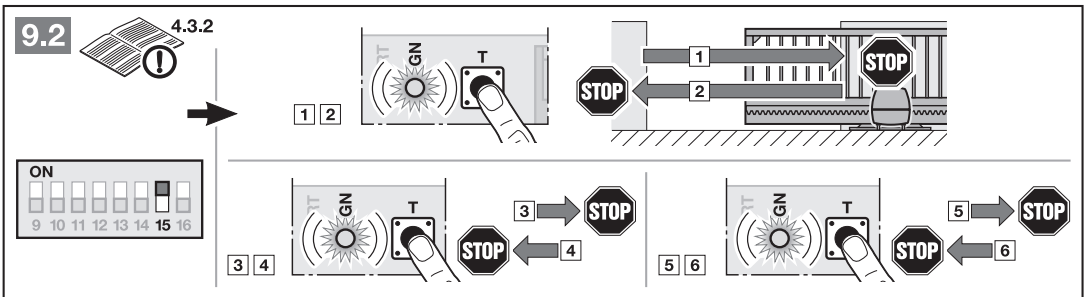
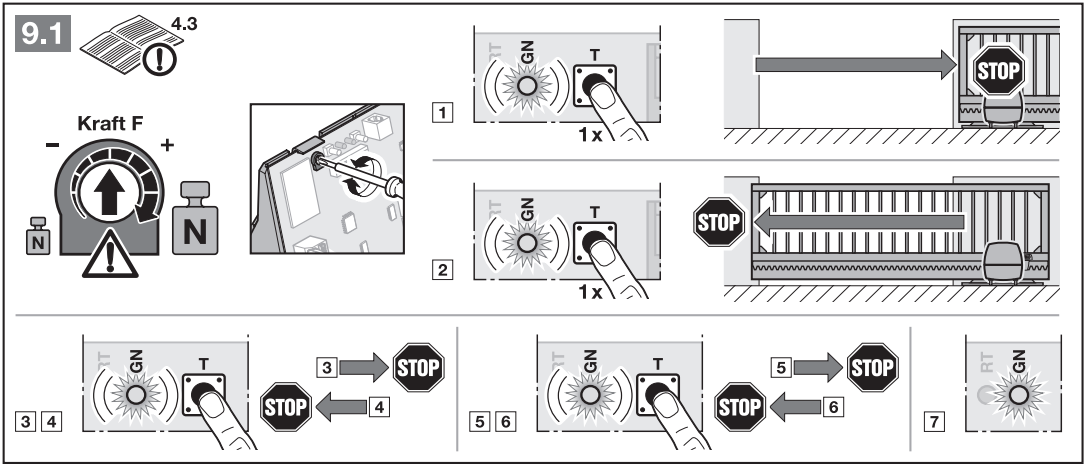

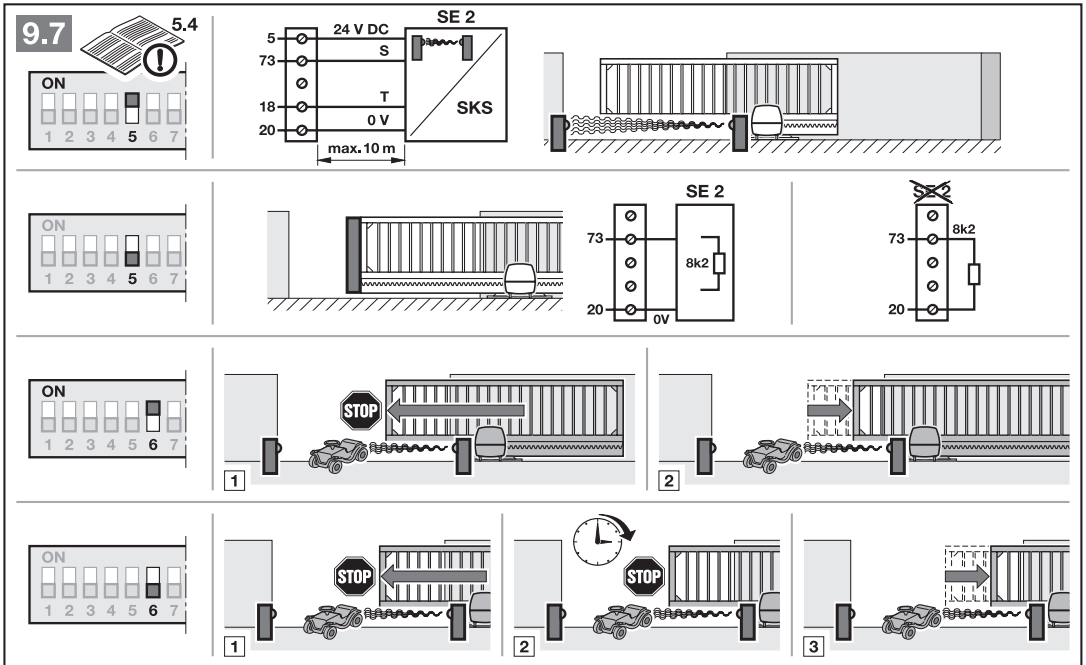
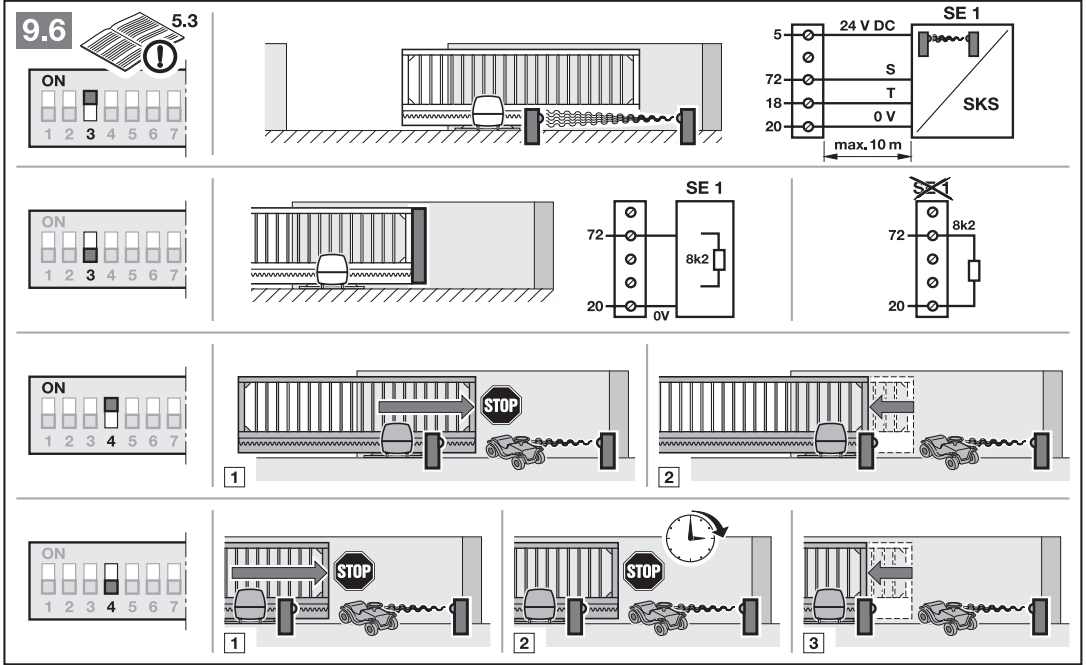
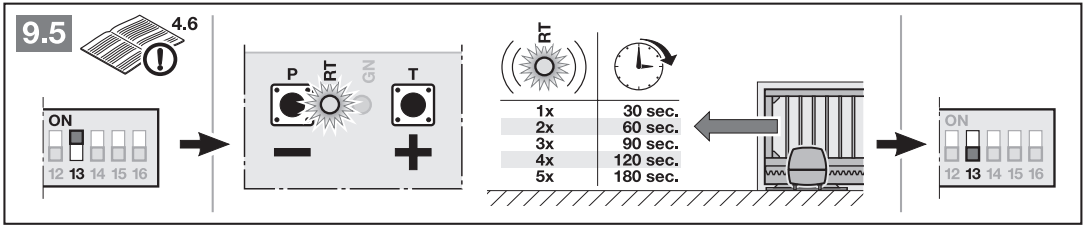

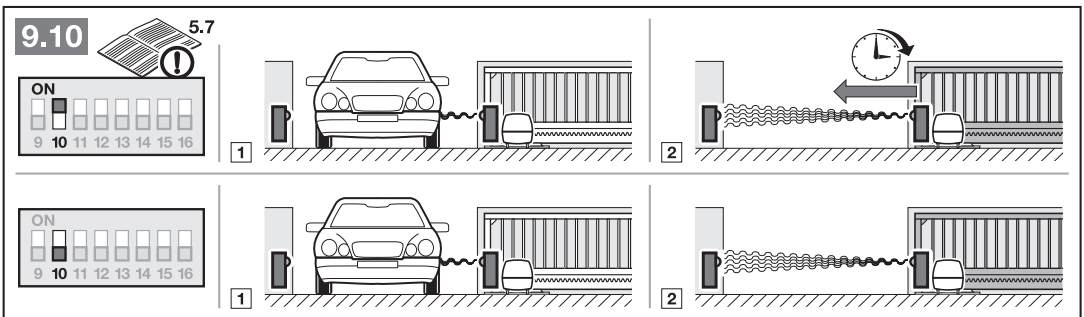
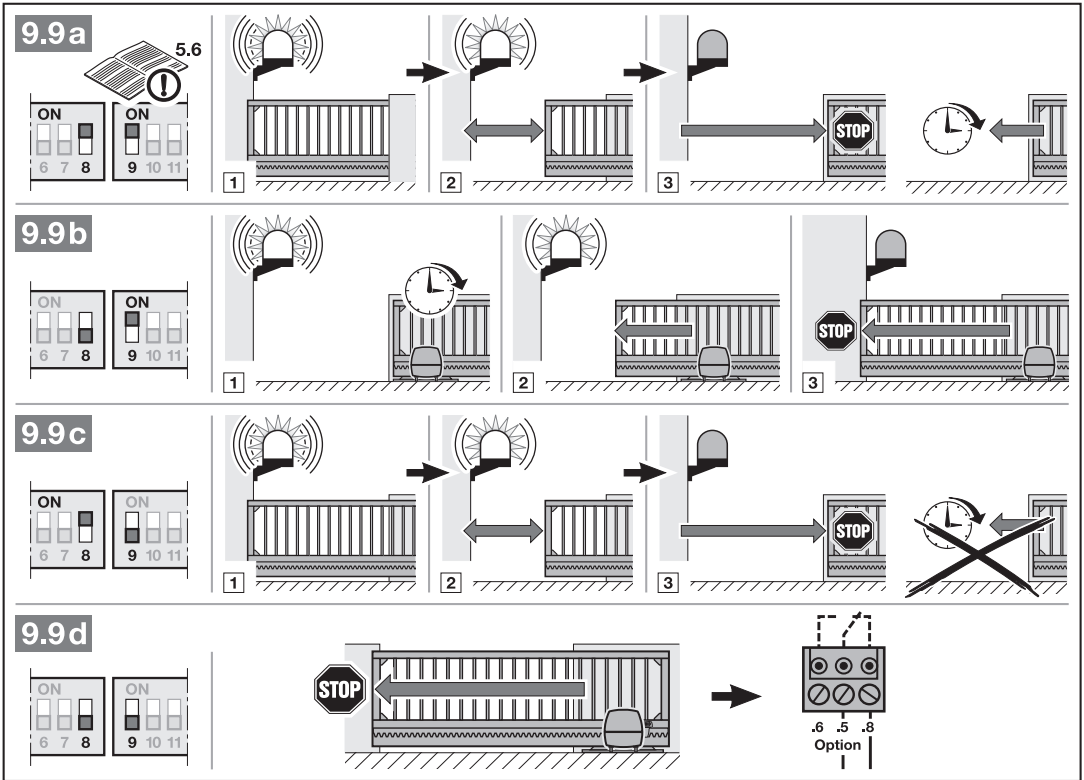
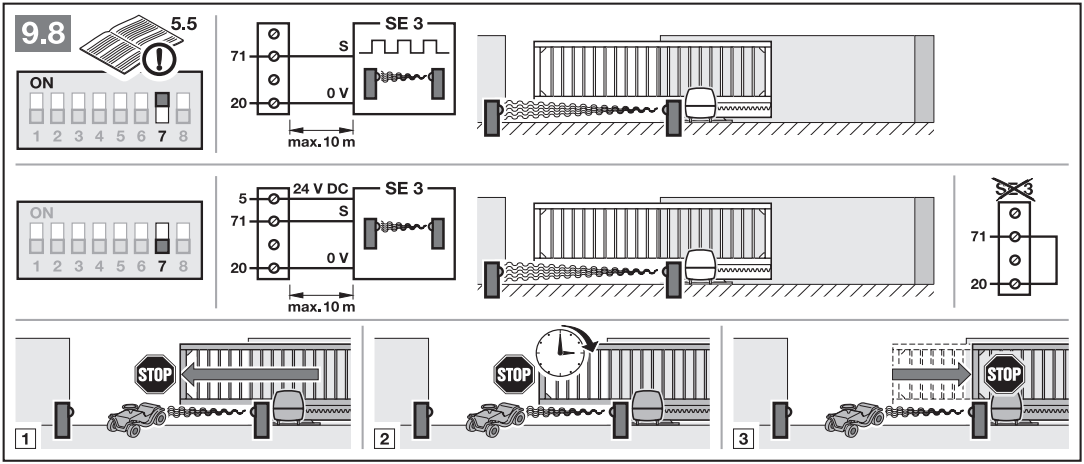

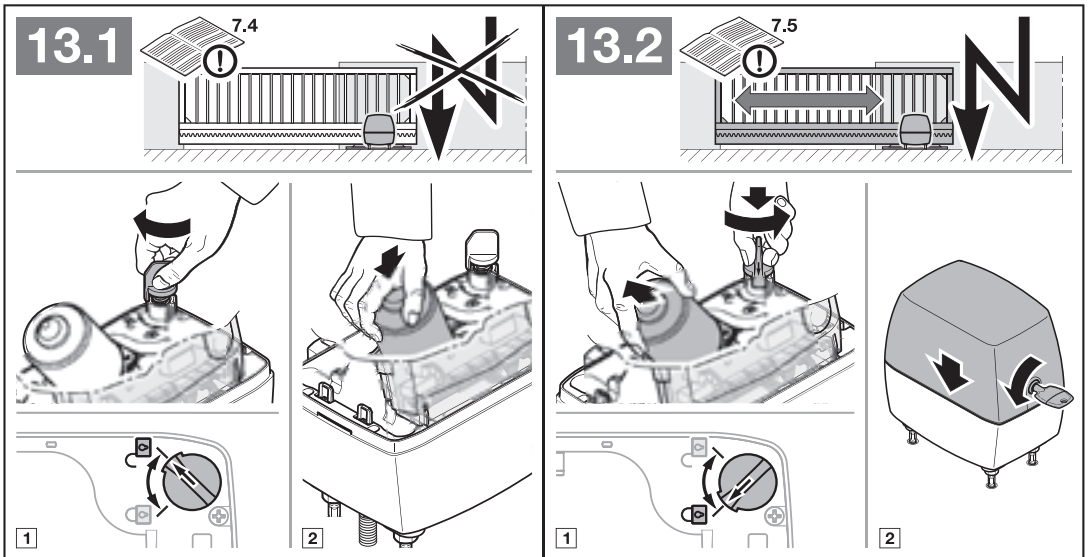
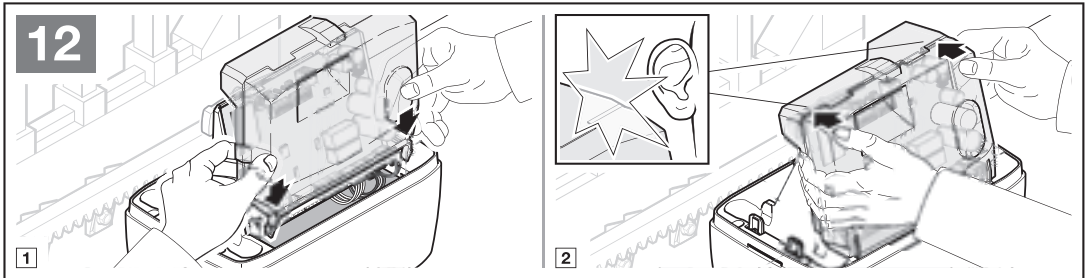

Instructions for Fitting, Operating and Maintenance
Sliding operator

C300-500-800

4Ddoors

GARAGE DOORS REDEFINED

www.4Ddoors.com