

3 094 144 RE / (Stand: 04.2015) Druck: 04.2015

EN

Operating Instructions

Side door with aluminium profile frame

A

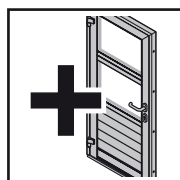
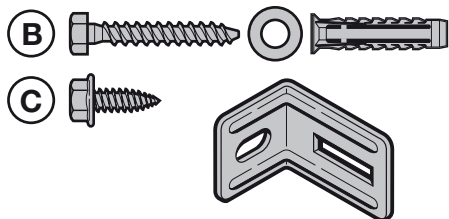
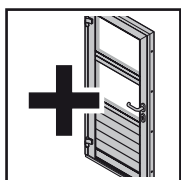
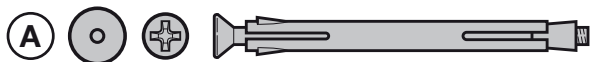
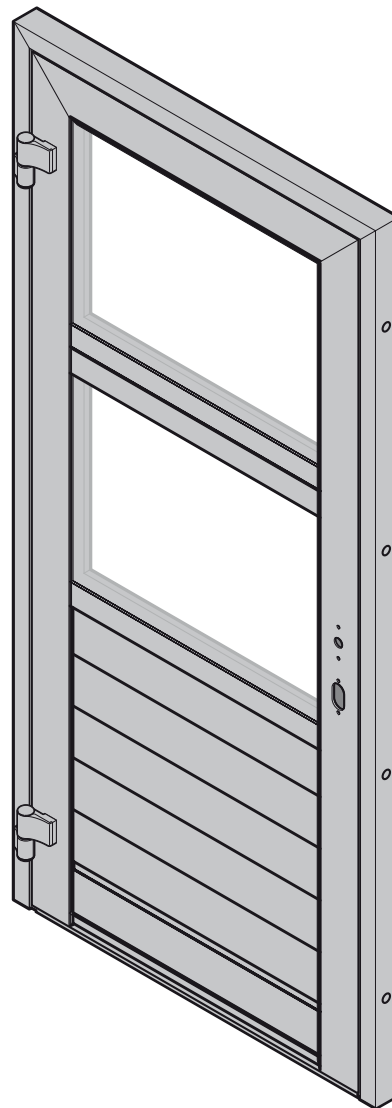
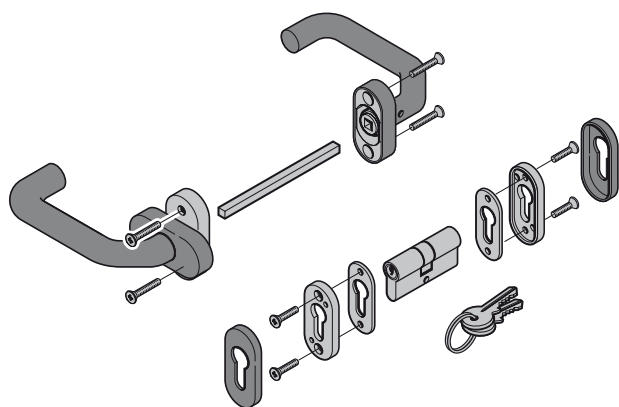

B

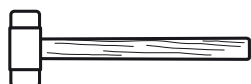

Ø 6/8/10
T30

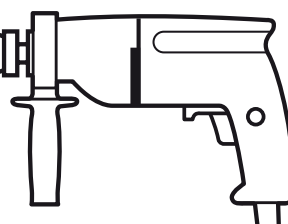
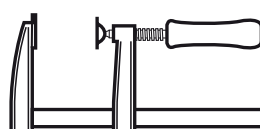
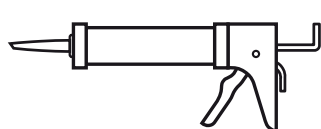

CONTENTS

A **Items supplied**.....2

B **Tools needed for assembly**.....2

1 **About These Instructions**.....6

1.1 Warnings used.....6

1.2 Symbols used.....6

1.3 Abbreviations used.....7

2 **Basic Safety Instructions**.....7

2.1 Liability7

3 **Fitting**.....7

4 **Inspection and Maintenance**7

4.1 Profile cylinder7

4.2 Hinges7

5 **Cleaning and Care**7

5.1 Surface7

5.2 Lock.....7

56

1 About These Instructions

Dear customer,

We are glad that you have decided on a quality product by our company.

These instructions are **original instructions** as outlined in the EC Directive 2006/42/EC. Read and follow these instructions carefully. They contain important information on the assembly, the operation and about the correct care/maintenance of the side door, so that you can enjoy this product for many years.









Please pay particular attention to all safety and warning notices.

Be sure to keep this manual in a safe place!

1.1 Warnings used

ATTENTION
Indicates a danger that can lead to damage or destruction of the product.

1.2 Symbols used

	Important note for avoiding damage to property
	Permissible arrangement or activity
	Non-permissible arrangement or activity
	Optional components
	Door open
	Door closed
	Maintenance-free
	Dispose of component/packaging

Dissemination as well as duplication of this document and the use and communication of its content are prohibited unless explicitly permitted. Noncompliance will result in damage compensation obligations. All rights reserved in the event of patent, utility model or design model registration. Subject to changes.

1.3 Abbreviations used

OFF Top edge of finished floor line

2 Basic Safety Instructions

- ▶ Attach all the fastenings listed in the fitting instructions.
- ▶ Protect your door until construction is completed by covering it with foil and tape to avoid damages. However, keep in mind that tape can leave residue or may damage the coating, especially under prolonged exposure to the sun.
- ▶ Protect the door from aggressive and caustic substances.

2.1 Liability

Failure to observe these notes and the following information releases the manufacturer from his liability.

3 Fitting

For simple and professional fitting, carefully carry out the steps described in the illustrated section.

In the threshold area, you have the following options:

Threshold rail with floor recess:

The bottom spacer profile later disappears in the screed.

Threshold rail without floor recess:

- ▶ Unscrew the bottom spacer profile and fasten the threshold rail profile on site.

4 Inspection and Maintenance

4.1 Profile cylinder

ATTENTION
<p>Oil on the profile cylinder</p> <p>The locking function of the profile cylinder can be compromised by the use of oil.</p> <ul style="list-style-type: none"> ▶ Never use oil for the profile cylinder.

4.2 Hinges

The door hinges are maintenance-free.

ATTENTION
<p>Greasing of the hinges</p> <p>If door hinges are greased, the bearings will wear out.</p> <ul style="list-style-type: none"> ▶ Never grease the door hinges.

5 Cleaning and Care

5.1 Surface

Clear water is sufficient for cleaning and care. Use warm water together with a neutral, non-abrasive cleaning agent (household detergent, pH value 7) if more heavily soiled.

- ▶ Clean the surface **at least every 3 months** to maintain the surface properties.

ATTENTION
<p>Damage from waterless cleaning</p> <p>Waterless cleaning damages the surface.</p> <ul style="list-style-type: none"> ▶ Never clean the surfaces without water. ▶ Only use soft textile cloths or chamois. ▶ Rinse off any dirt and dust particles with clear water before rubbing off.

5.2 Lock

Perform upkeep on the lock and the lock cylinder 1 to 2 times per year, so that the door can be easily and quietly closed:

- ▶ Grease the rear side of the lock latch with Vaseline.
- ▶ Spray a special profile cylinder care product into the lock channel (available in specialised shops).